

Hermann Koller

ORBIS PICTUS LATINUS

Vocabularius imaginibus illustratus

Lateinisches Bildlexikon

Dictionnaire latin illustré

Illustrated Latin Dictionary

Dizionario latino illustrato

Diccionario latín ilustrado

Artemis & Winkler

Die Deutsche Nationalbibliothek verzeichnet diese Publikation
in der Deutschen Nationalbibliographie; detaillierte bibliographische Daten
sind im Internet über <http://dnb.d-nb.de> abrufbar.

© 1976 Artemis & Winkler Verlag
© 2008 Patmos Verlag GmbH & Co. KG
Artemis & Winkler Verlag, Düsseldorf
Alle Rechte vorbehalten.
Umschlagmotiv: Pallas Athene und Zeus
Printed in Germany
ISBN 978-3-538-07268-8
www.artemis&winkler.de

Praefatio

Quid hic libellus velit, iis, quae Iohannes Amos Comenius Orbi Sensualium Picto suo praemiserat, optime declaratur: „Sensus ... obiecta sua semper quaerunt, absentibus illis hebescunt, taedioque sui huc illuc se vertunt; praesentibus autem obiectis suis hilaescunt, vivescunt, et se illis affigi, donec res satis perspecta sit, libenter patiuntur. Libellus ergo hic ingenii ... captivandis et ad altiora studia praeparandis bonam navabit operam.“

Nimium saepe notiones sermone Latino expressae non re vera perspiciuntur quia desunt cogitationes repraesentationesque rerum in animis lectorum saepiusque earum in loco auditur merus strepitus vocum nihil significantium. Huic infirmitati docendi mederi studebat Comenius primo vocabulario Latino imaginibus illustrato, quem posteriores multi imitati sunt — ad illustrandos sermones vernaculos! Lingua Latina autem adhuc caret vocabulario imaginibus illustrante res et conceptus peculiare Latinos, inter quos etiam adnumeranda sunt omnia, quae in Latinitate mediaevali hodiernaque accesserunt, nec non Graeca sub forma Latina in usum cottidianum introducta. Conatus sum illustrare notiones in litteris Latinis saepius occurrentes, ea autem intentione, ut res Romanae documentis Romanis demonstrarentur. Ad hanc rem perpetranda maximo usui mihi fuerunt A. Rich et Daremberg-Saglio, qui hodie perpaucis prae manu sunt. Eorum delineamentis saepe usus sum in conscribendo hoc libello. Definitiones autem verborum plerumque Forcellinio Thesauraque Linguae Latinae adiuvantibus confeci ita, ut breviores et ad captum discipulorum lectorumque inexpertorum aptiores fierent.

Insunt aliquot imagines, quae non ab omnibus rerum antiquarum peritis eodem modo explicabuntur. Cura mihi fuit in componendo hoc opusculo didactico, ut imagines vocabula in auctoribus inventa ante oculos ponerent, non ut in rebus dubiis iudicis mihi partes vindicarem. omnibus hoc libello comprehensis aut in schola cum discipulis aut in colloquiis Latinis Universitatis studiorum Turicensis cum studiosis aliquot annos usus sum ad legendos et interpretandos auctores Latinos. Latina autem Latine tractanda esse iam dudum mihi, monente Erasmo, persuasum est.

Lemmata huius opusculi non comprehendunt omnia, quae in legendis antiquorum scriptis explicatione egent. Multa desiderabuntur, quia nonnumquam imagines bene distincteque delineatas invenire non potui. Adiunxi proprio Marte aliquot mediaevalia et hodierna ut omnia se vicissim explicarent in libro et ut nexus idearum conceptuumque inter tempora antiqua et hodierna dilucidior fieret. Eodem spectant exempla e Margarita Philosophica, Historia de Gentibus Septentrionalibus, Orbe Sensualium Picto aliisque sumpta, quae demonstrabunt sermonem Latinum plus quam duo milia annorum viguisse semperque in flore esse.

Spero fore, ut hoc opusculum non inter semel legendos, ut ait Plinius, sed saepissime lectitandos libros collocetur. Sit venia primum experienti!

Turici, mense Septembri MCMLXXVI

signa

- * = uno asterisco notantur verba Latinitatis christianae,
- ** = duobus asteriscis verba mediaevalia,
- *** = tribus asteriscis verba hodierna.

litteris cursivis impressa sunt verba in proprio lemmate occurrentia.

linea subnotata sunt

- a) verba, quae non lemma faciunt sed in textu explicantur. inveniuntur etiam in indice generali.
- b) nomina auctorum qui citantur.

quantitates syllabarum interdum designantur (¯ = syllaba longa, ˇ = syllaba brevis) ut expeditius legi possit textus.

abacus —i, m.

- a) abacus est tabula calculatoria, qua utebantur arithmetici et geometrae.
b) abacus est tabula lusoria.

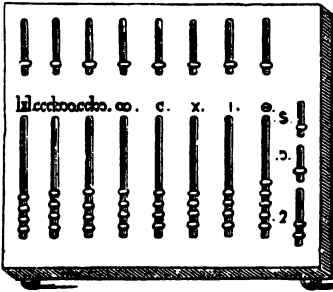

- c) abacus erat etiam mensa vel tabula multis areis (area) iisque excavatis distincta, in quibus arceoli immittebantur et exponebantur oleo aut vino referti. saepe abaci exquisitā elegantia facti, aerati ornatique sunt, in iisque exponebantur vasa aurea, argentea pretiosaque.

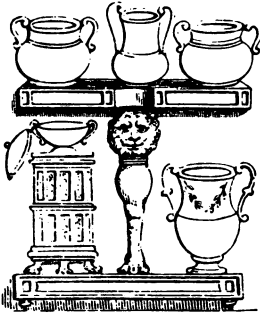

- d) abaci dictae sunt etiam crustae, tabulae quadratae e marmore, vitro aut simili materia, quae multicolorae et imagines aliquas repraesentantes parietibus insertae erant, iis tectorii (tectorium) vice insertae.

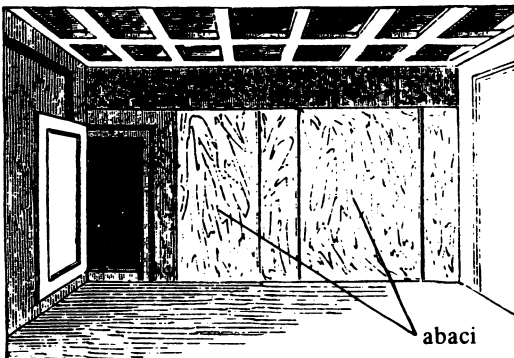

- e) abacus in architectura est quadrata planities in summis columnarum capitulis (columna, capitulum).

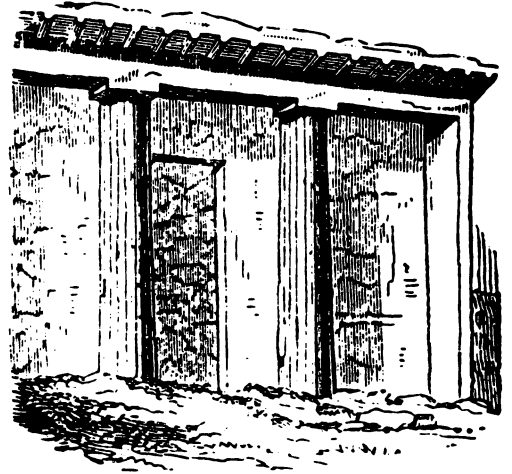

acanthus —i, m.

- acanthus est nomen commune cuiusque plantae spinosae, peculiariter est herba folio quam lactucae latiore multo et longiore, erucae modo incisuris divisa et laciniosa, in hortis nascens et locis humentibus (Acanthus spinosus L.). foliis acanthi capitulum Corinthium formatur: vide duo exempla in imaginibus.



folia acanthi

aconitum –i, n.

herba venenata foliis cyclaminis aut cucumeris, non pluribus quattuor, ab radice leniter hirsuta: aconitum etiam ponitur de quocumque veneno: **Ovidius**, *Met.* 1, 147: „lurida terribiles miscent aconita novercae.“

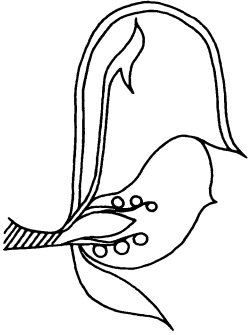

flos aconiti



acroteria
in templis
Romanis

acroterium –i, n.

significat summitatem, extremitatem, verticem (*vertex*) cuiuscumque rei. acroteria sunt parvae statuæ seu sigilla, quae fastigiis (*fastigium*) templorum domuumque imponuntur, v. g. capita leonina aut humana, item integrae imagunculae, et alia huiusmodi ornatus gratiã.



acroterium in fastigio templi Aeginae

acus –ūs, f. aut m.

acus est minimum acutissimumque instrumentum, quod constat ex ferro aliove metallo aut

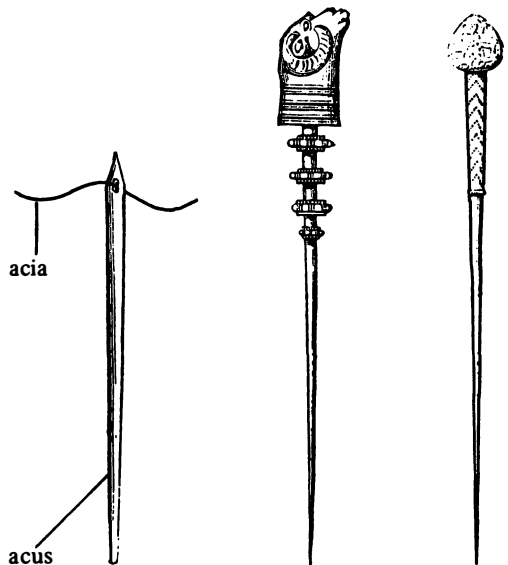

etiam ex eburno, et pluribus inservit usibus, ex. gr. vestibus consuendis aut ornandis.

formula: immittere lina per acum.

proverbium: acū rem tangere = est rem divinare. **verbum:** acuo, -ui, -utum, -ere = aciem ferri excitare, trahere, et proprie ponitur de falce, cultro (*culter*) etc. cui contrarium est „obtundere“.

acia -ae, f.

est filum in acu ad suendum.

proverbium:

„ab aciā et acū omnia exponere“, quod significat vel minutissimas res narrando exponere, totamque alicuius facti seriem alte ductis initiis diligenter nihilque prorsus omittendo explicare.

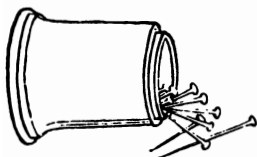

capsa acum

adorans -antis, m. f., vel orans, -antis, m. f.

adorare = aliquem aliquid rogare alloquendo, deos adorare = deos precari.

gestūs adorandi:

habitus autem adorantium erat, ut dexteram ad os referrent et totum corpus **dextrorsum** circumagerent, aut ambas manūs palmis (**palma**) apertis ad caelum tollerent.



adorans, vel orans, e Callixti catacumbis, Romae

aedicula -ae, f.

est parva aedium pars, cella, cubiculum. ponitur etiam pro parva aede sacra, sacello.

Petronius, Sat. 29 in fine:

„grande armarium in angulo vidi, in cuius aedicula erant **Lares** argentei positi Venerisque signum marmoreum.“

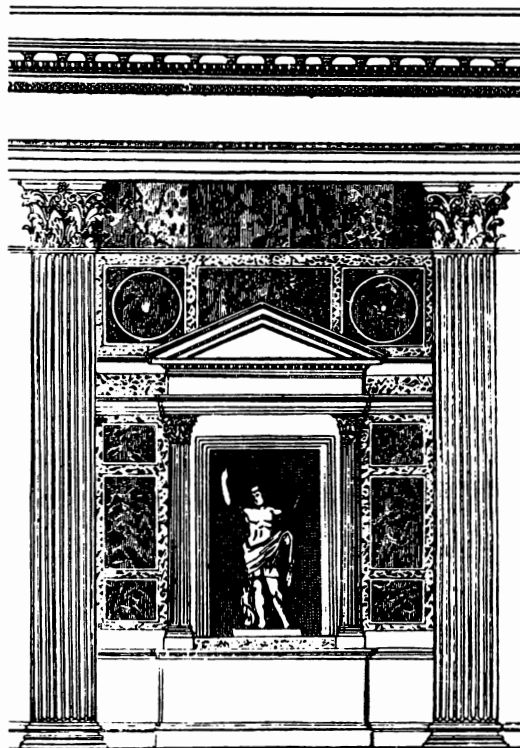

aedicula in Pantheone Romano (*Pantheon*)

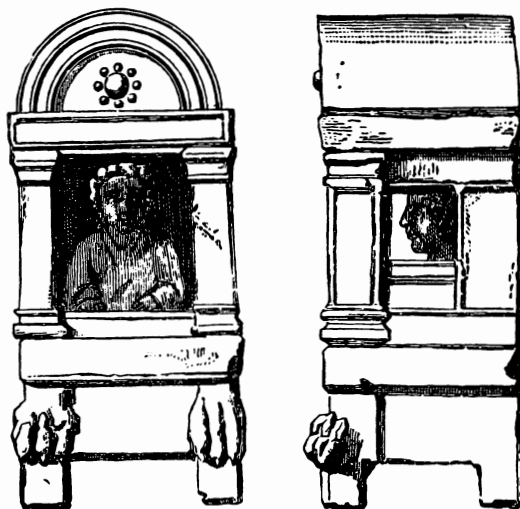

aedicula portatilis



aedicula portatilis

aedituus –i, m.

aedituus (vel aeditumus) est sacrae aedis custos.
Plautus, *Curc.* 203/04:
 „... sonitum et crepitum claustrorum audio,
 aedituum aperire fanum ...“



aegis –idis, f. (acc. Graec. –ida)

a) est pellis caprae.
 b) aegis est munimentum pectoris aeneum,
 habens in medio Gorgonis caput.
Ovidius, *Met.* 6, 79:
 „defenditur aegide pectus.“

c) ceterum aegis est scutum, quod ab antiquis Iovi et Palladi tantum tribuitur.

Vergilius, *Aen.* 8, 354/55:

„credunt se vidisse Iovem, cum saepe nigrantem
 aegida concuteret dextrā nimbosque cieret.“



aegis Palladis



aegis = lorica

Aesculapius –i, m.

est deus medicinae artis auctor et medicinarum
 inventor. eius *symbolum* est baculum cui
 serpens inhaeret.



aetates hominis

hoc modo **Amos Comenius** in opere, cui titulus est Orbis Sensualium Pictus septem aetates

hominis gradibus ascendentibus et descendentibus scalae repraesentat:

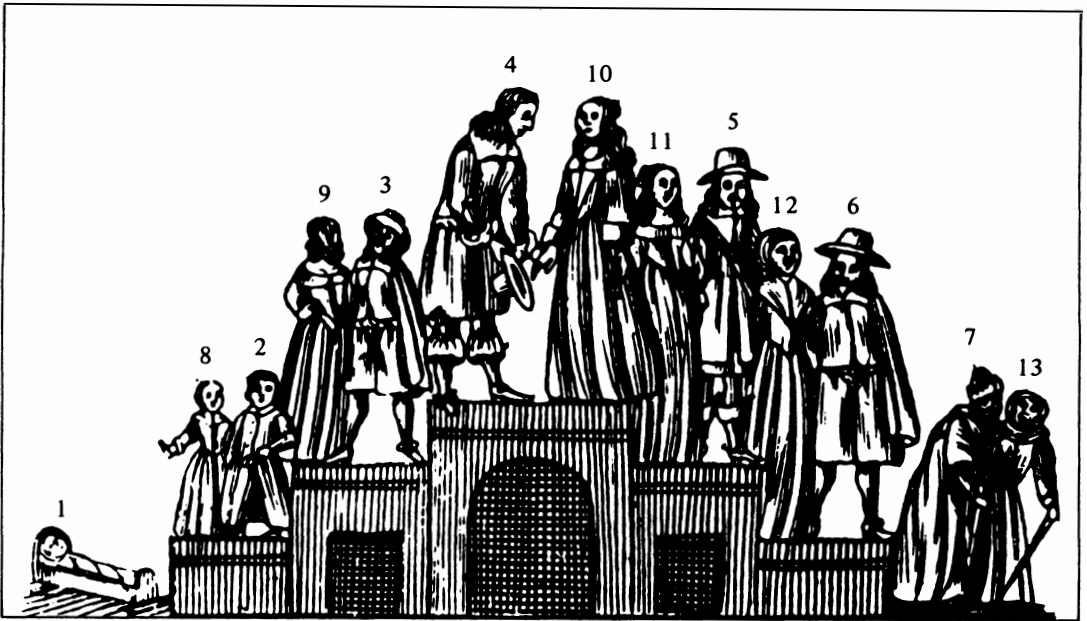

- | | | | |
|--------------|---------------|---------------------------|-------------------|
| 1 infans | 5 vir | sic etiam in altero sexu: | |
| 2 puer | 6 senex | 8 pupa | 11 mulier |
| 3 adolescens | 7 silicernium | 9 puella | 12 vetula |
| 4 iuvenis | | 10 virgo | 13 anus decrepita |

affinitas –atis, f.

a) affinis est is, qui mihi vicinus est, cuius agri finem communem habent cum meis.

b) affines sunt, qui per nuptias copulantur.
gradus affinitatis sunt:

socer / socrus (–ūs, f.)
(pater / mater mariti)

socer / socrus (–ūs, f.)
(pater / mater uxoris)

levir
(frater mariti)

glos
(soror mariti)

maritus

uxor

nurus (–ūs, f.) — filius
(uxor filii)

filia — gener
(maritus filiae)

noverca est uxor, quam vir post mortem primae uxoris in matrimonium ducit.
vitricus est maritus, cui femina post mortem

primi mariti nubit.
privignus est filius primi matrimonii,
privigna est filia primi matrimonii.

agitator –oris, m.

agitator proprie est qui agit; sed speciatim est qui equos aut alia iumenta agit, auriga.

Cicero, Acad. 2, 94:

„ego, ut agitator callidus, priusquam ad finem veniam, equos sustinebo.“



agitator equorum



auriga



agitator aselli

album –i, n.

a) erat tabula dealbata gypso illito, in qua nonnulla perscribebantur et proponebantur in publico, ut ab omnibus legi possent.

Livius, 9, 46 de Cn. Flavio:

„civile ius ... evulgavit fastosque circa forum in albo proposuit, ut, quando lege agi posset, sciretur.“

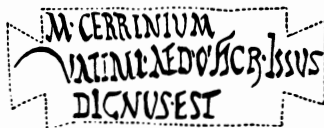

b) tabula, in qua perscribebantur praetorum edicta, actiones, interdicta, actionum formulae, item litigatorum nomina actionesque, et alia huiusmodi ad forum civilesque contentiones spectantia.

c) album significabat etiam nominum indicem (*index*), in quem omnes alicuius classis homines referebantur: album senatorum, etc.

allocutio –onis, f.

allocutio = nomen verbale verbi „ad-loquor“. allocutio est oratio, qua imperator milites ad pugnam hortatur.



allocutio imperatoris Romani in opere caelato.

1 imperator 2 lictores 3 signiferi 4 signa 5 vexillum 6 suggestum

alticinctus –i, m. (adi. –us, –a, –um)

est alte cinctas vestes habens; dicitur de homine negotioso, qui alte cingit *vestimentum*, ut in opere expeditior sit.



alvearium –i, n.

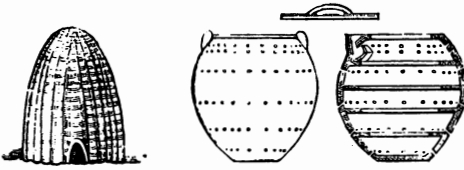

a) est vas in alvei modum cavatum.
b) speciatim occurrit pro vase, in quo apes nidificant et mellificant.

Vergilius, Georg. 4, 33 ss.:
„ipsa autem seu corticibus tibi suta cavatis seu lento fuerint alvearia vimine texta, angustos habeant aditus ...“

Columella, R. R. 9, 5, 3:

„ubicumque fuerint alvearia, non editissimo claudantur muro.“

c) latiore sensu ponitur pro loco, in quo sunt alvearia, quod et apiarium dicitur.

****ambo** –onis, m.

ambo est apud ecclesiasticos scriptores suggestus seu pulpitum, in quo stant contionaturi. in basilicis (*basilica*) christianis duo ambones erant, in sinistro epistula legebatur, in dextro evangelium. Cassiodorus, Hist. Eccl. 10, 4:

„episcopus residens super ambonem, ubi solebat consuete facere sermonem.“

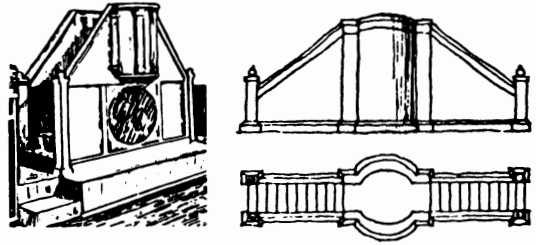

amphitheatrum –i, n.

est aedificium circulari seu potius ovali formā, in usum spectaculorum exstructum. in eo erant gradūs circum undique, et sedilia disposita ad spectandum, in medio spatium, quod arena dicebatur, quia arenā spargi solebat, ut ludentes

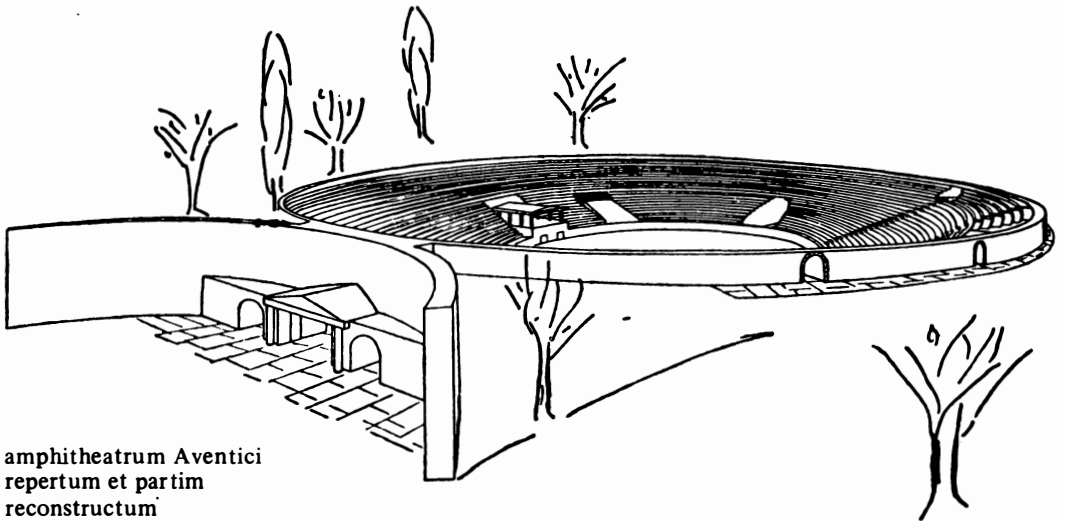

amphitheatrum Aventici repertum et partim reconstructum

commodius insisterent. praecipua certamina erant gladiatoria, venationes et damnatorum pugnae cum feris, *naumachiae* etc. non solum Romae, sed in omnibus oppidis provinciarum ubi milites stativa habebant, amphitheatra aedificata sunt.

amphora –ae, f.

est genus vasis, plerumque fictilis. habebat utrimque ansas (*ansa*). inserviebat praecipue ad liquores (oleum, vinum) condendos. amphorae in inferiore parte erant acutae, ut in abaco aut in harenā poni possent.

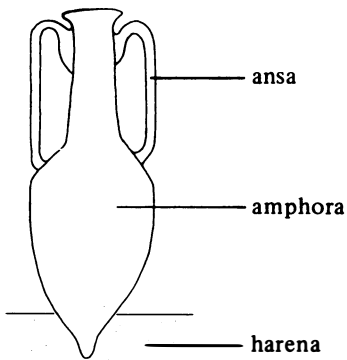

ampulla –ae, f.

est vasis genus ex vitro aut alia materia, turgidum velut inflato ventre, et angusto ore, quo oleum veteres in balneis (*balneum*) servabant; item quo in mensa ad acetum continendum, aliquando etiam ad bibendum utebantur.

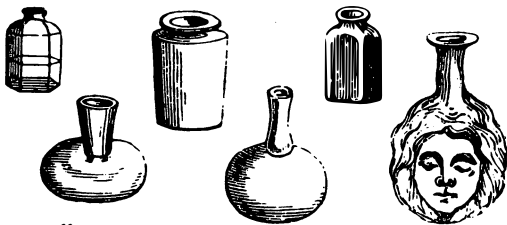

ampullae



ampulla olearia

ancora –ae, f.

est ferreum instrumentum duobus instructum veluti brachiis (*bracchium*) aduncis, quod alligatum fune (*funis*) in mare iacitur et fundo adhaerens naves detinet.

translate: ancoras tollere significat abire, discedere.

**ancora *symbolum* erat quo Christus significabatur.

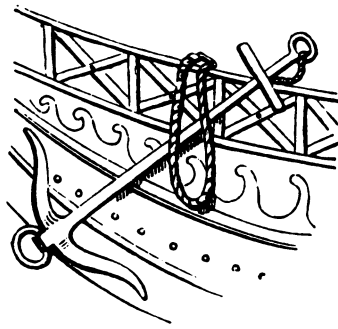

Anglia sive Britannia Romana



GENTES

- o coloniae
- oppida
- o castra legionis

ansa –ae, f.

est manubrium quo vas aut quodcumque aliud manu prehendi et teneri potest.

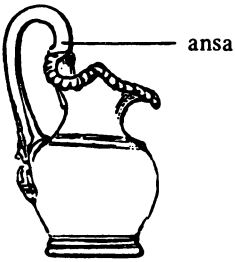

ansa statērae est pars illa, quae manu tenetur, habetque anulo suspensum scapus, qui in ea versatur.

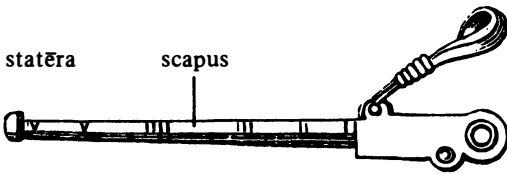

ansa gubernaculi est summa pars gubernaculi, quam gubernator manu tenet.

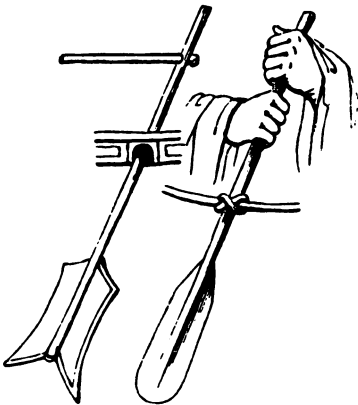

ansa ostii est anulus ferreus ostio (ostium) infixus, ad aperiendum, claudendum vel etiam pulsandum.

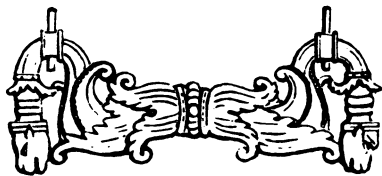

ansa crepidae aut vestium est vinculum et habenula, qua soleae (solea) et crepidae pedi alligantur, aut vestes in aliqua corporis parte constringuntur.

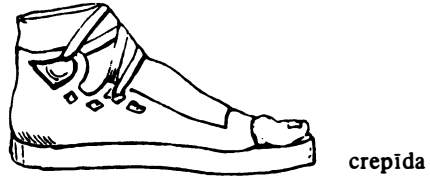

antefixum –i, n.

est parvum signum, corolla, aliudque huiusmodi ornamentum ex opere figulino, quod tecto aedis affigitur sub stillicidio. stillicidium est locus, unde aqua tectorum in terram decedit.



hoc antefixum fictile Argonautas cum dea Minerva monstrat

antlia –ae, f.

est machina ad hauriendam ex imo loco aquam, quae pedum alterno nisu et agitato aquas per modiolos atque haustra attollit.

Martialis, 9, 18:

„sed de valle brevi, quas det sitientibus hortis,
curva laboratas antlia tollit aquas.“

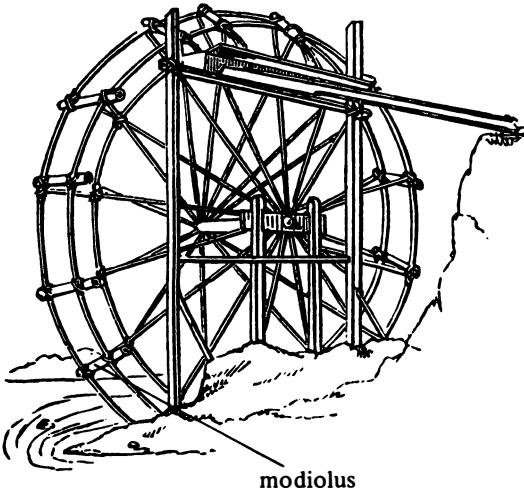

modiolus

antrum –i, n.

antrum est caverna, quae praecipue silvestrem quandam pulchritudinem prae se ferat, et aestatis tempore frigidum amoenumque recessum praebet, aut alicui numini sacra sit. est vox poetis quam aliis usitatior.

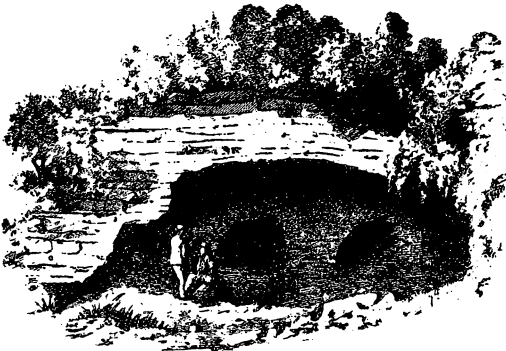

aplustre –is, n.

significat navis ornamentum ex tabulis confectum, et in summitate *puppis* positum, et plerumque in modum pinnarum aut cristae (*crista*) formatum et versus *proram* recurvum.

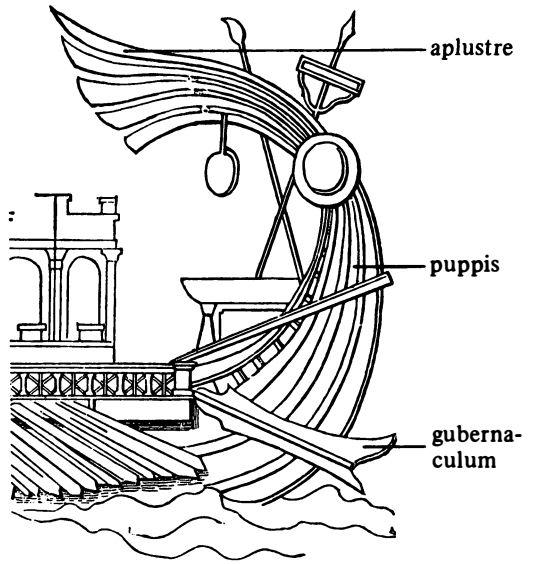

aplustre

puppis

gubernaculum

aplustre cum ancora

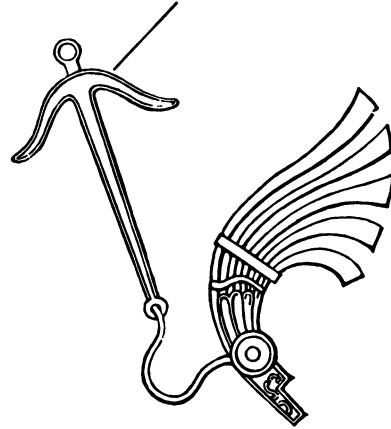

Apollo –inis, m.

Apollo (vel Phoebus), Latonae et Iovis filius, frater Artemidis (Dianae). Deus est vatum (*vates*), venator est munitus arcu (*arcus*) et sagittā, artibus Musarum (*Musae*) praesidet et eas ad choream ducit lyrā canens; etiam citharædus dicitur, i. e. ad citharam vel lyram canens.

de Apolline Horatius in Carmine Saeculari (61/62):

„*Augur* et fulgente decorus arcu
Phoebus acceptusque novem Camenis.“ (= Musis)

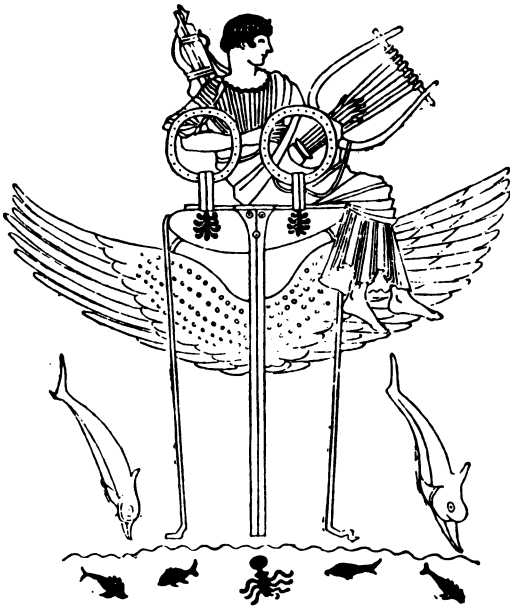

Apollo in tripode (*tripus*) sedens, supra mare volat, lyrā canens; arcu munitus est (= vates est, citharoedus et venator).

nomen graecum, relationem hominis in deos significans. quae relatio multis in fabulis narratur; nam Ganymedes, Thalia multique alii a Iove sub forma aquilae in caelum erepti esse dicebantur, sicut etiam Hylas a nymphis fontis, Oreithya a Borea, deo ventorum. hi homines, a deis rapti, immortalitate donati et semidei, i.e. heroes facti sunt.



eodem modo etiam *consecratio* imperatorum depingitur, ut in hoc opere caelato, ubi Titus ab aquila in caelum tollitur

apotheōsis —is, f.

aquaeductus —ūs, m.

vel aquae ductus, est structura, quā aqua deducitur, sive ea subterranea sit per cuniculos (*cuniculus*), sive ex opere arcuato.



Thalia ab aquila Iovis in caelum sublata in pictura vasis Graeci

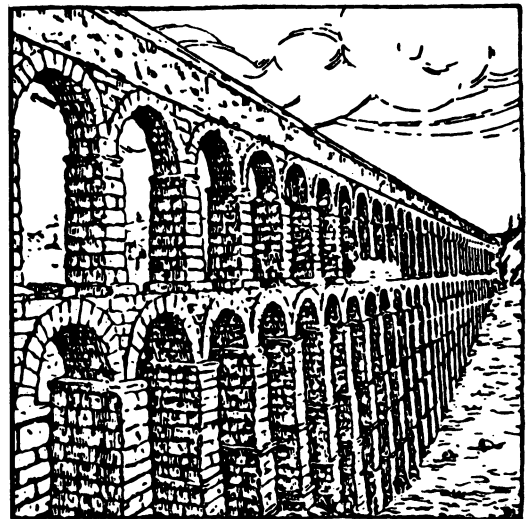

aquaeductus ex opere arcuato apud Segoviam (in Hispania)

aquila —ae, f.

a) est avis ex genere rapacium, maximis valens viribus, ceterarumque pugnacissima et generosissima; ob id avium regina appellata.

b) quoniam in auguriis (*augurium*) volatus aquilae omnium prosperrimus a Romanis habitus est, factum est, ut aquilae signum in exercitu ferre instituerint. itaque principem locum inter *signa* exercitūs aquila obtinebat, quae longae infixae perticae gestabatur, alis plerumque expansis et in unguibus tenens fulmina; singulae legiones suam habebant aquilam.



ara —ae, f.

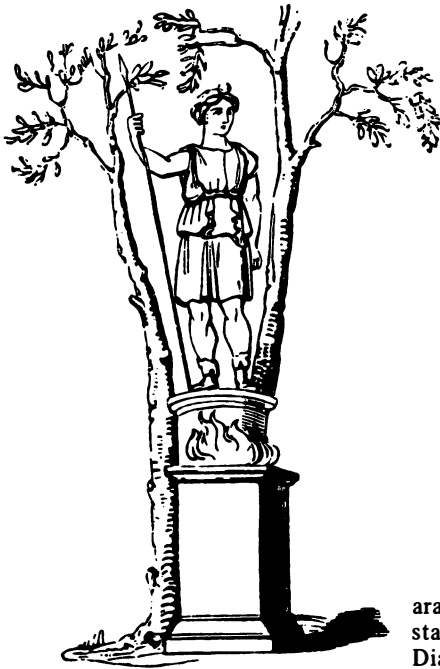

ara cum
statua
Dianae

a) ara est exstructio quae ex saxis, terrā, vel etiam lignis fit formā quadratā et superficie (*superficies*) planā.

b) ara est locus exstructus saepe quadratā formā, sacrorum seu victimarum immolandarum causā. altare —is, n., pl. —aria, sunt loca ad sacrificandum apta; proprie altaria sunt gradus super aram elevatus, in quo hostia igni adolebatur.

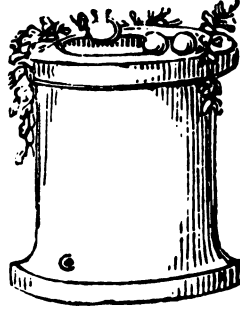

aratrum —i, n.

est instrumentum rusticum quo agri laborantur. prima imago aratrum simplex, e bure et vomere compositum, monstrat.

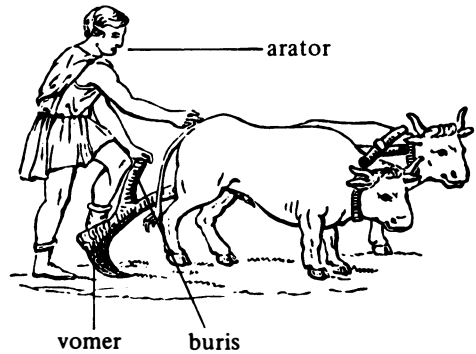

secunda imago aratrum perfectius continet.

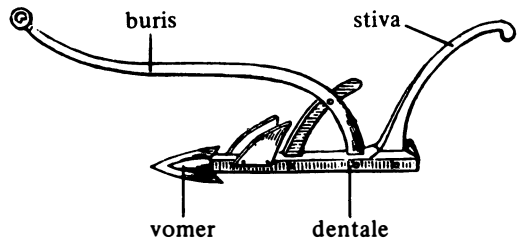

tertium aratrum rotis, temone et cultro instructum est.

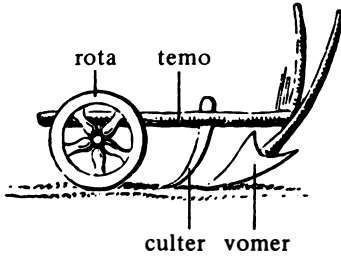

reponuntur; arca usurpatur pro receptaculo nummorum.

formula: „ex arca domoque“ solvere aliquid = praesenti pecunia et ex domo sua debitum solvere.

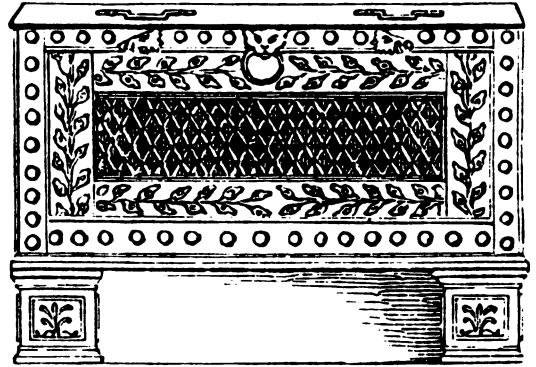

arca –ae, f.

arca est quidquid hominibus aut rebus claudendis et custodiendis inservit, **receptaculum**, in quo aliquid custoditur. in arca vestiaria vestes

architectus –i, m.

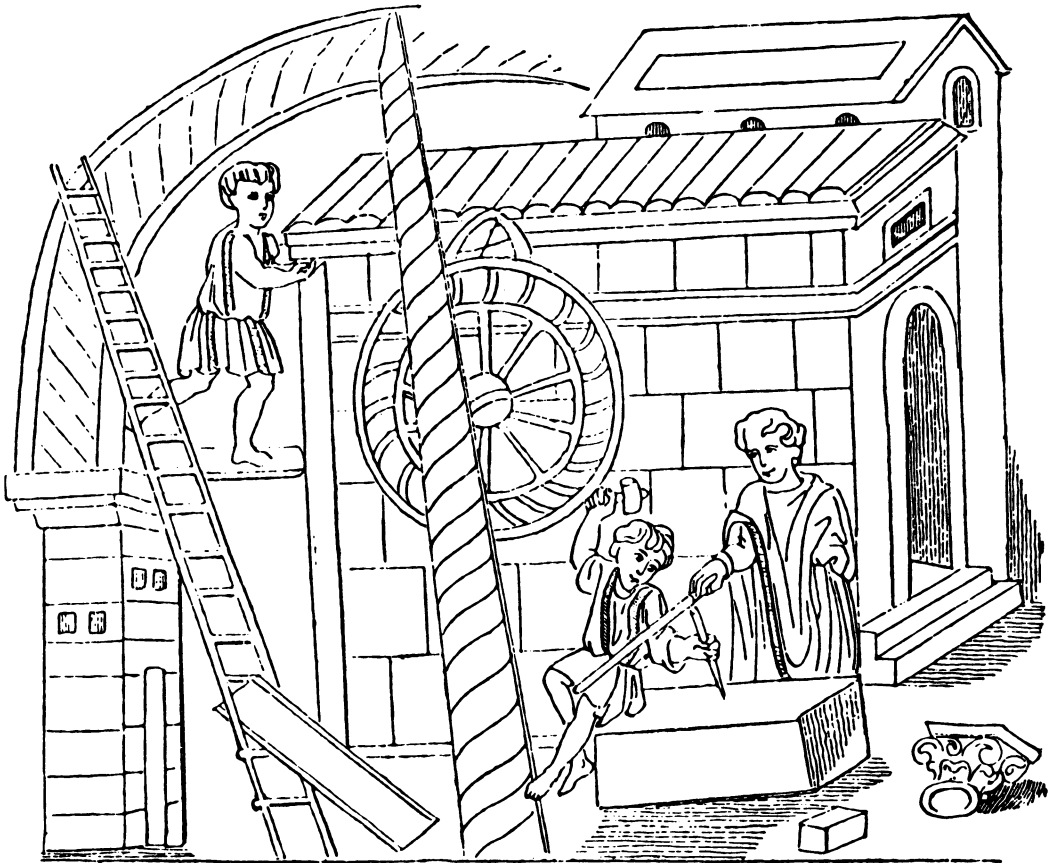

est praefectus structorum.
accipitur pro eo, qui architecturae artem callet,
et in aedificiis aliisque structuris symmetriam,
decorem ac distributionem omni studio consec-
tatur. proverbium: „architectus architecto
invidet“, de iis, qui in eadem arte versantur,
cuius similitudo aemulationem et invidiam
conciliare solet.

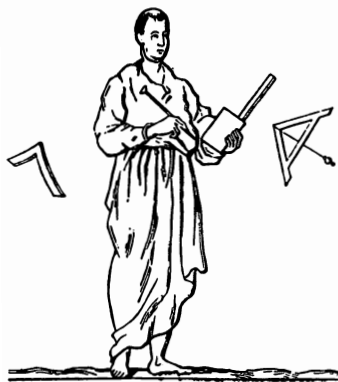

architectus manibus stilum et *codicillum* tenens.
sinistrā *norma* in pariete pendet, dextrā *perpen-
diculum*.

arcus —ūs, m.

arcus est instrumentum ex ligno aut alia materia,
quod intento nervo incurvatur et remittitur ad
iaciendas sagittas.



sagittarius barbarus (bracas (*bracae*) portans!)
manu dextra nervum arcūs tendit.



pharetra cum sagittis
et arcū

translate ob similitudinem dicitur „arcus“ quid-
quid eiusdem arcūs formam prae se fert, v. g.
arcus dicitur Iris caelestis. in architectura
„arcus“ dicitur structura in modum arcūs cur-
vata. huiusmodi sunt, qui a natura ipsa in antris
formantur; qui substruuntur ad sustinendas
aedes aut pontes (*pons*); qui ad *aquaeductus*
erigendos, et qui eriguntur clari alicuius trium-
phi causa, ideo „triumphales“ appellati; quorum
adhuc aliquot visuntur Romae et circa Urbem
imperatoribus dicati ob insignes ab iis partas
victorias.

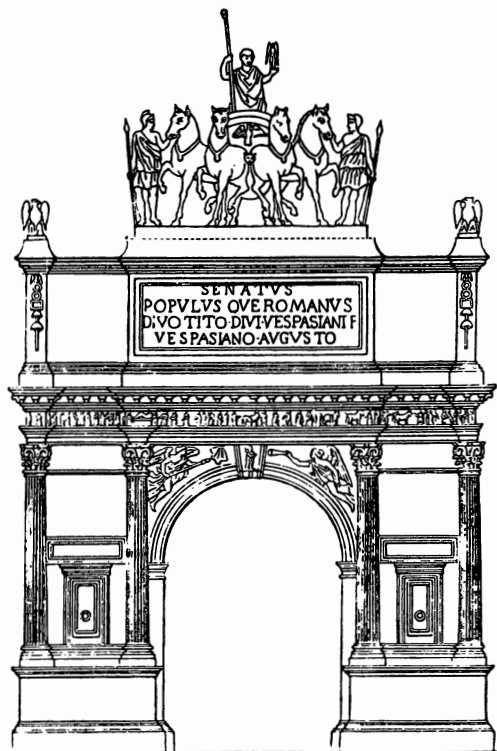

arcus Titi imperatoris Romae erectus.
fastigium eius tenet currus (*quadriga*) triumphalis.

area –ae, f.

- a) area est locus vacuus et aridus, area est planities, in qua frumenta secta teruntur et arescunt.
b) area dicitur locus in urbe purus, h. e. vacuus, in quo aedificari potest, et quod dirutis aedibus manet.
c) item area dicitur locus vacuus inter urbana aedificia, cuiusmodi sunt plateae, etc. ex. gr. area Capitolii, area Palatina. in antiqua forma urbis Romae Area Radicaria indicatur. areae saepe amplis porticibus (*porticus*) cingebantur, ut venientium turba consistere posset.

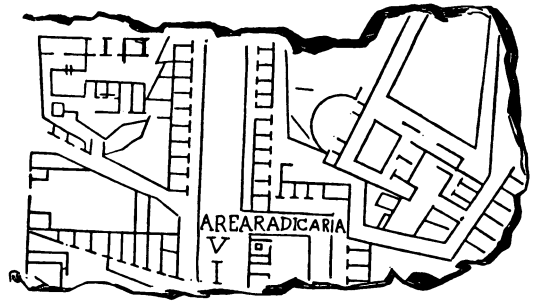

Argo –us, f.

- a) fuit in fabulis *navis* celeberrima et prima dicta, qua *Iason* cum flore iuventutis in Colchidem navigavit *vellusque aureum* a *Medea* adiutus in Graeciam reportavit.

- b) est etiam *sidus*; fabulantur enim poetae a *Minerva* post peractam navigationem in caelum translata esse, quod sua ope et consilio facta, et quod prima percurrisset mare.

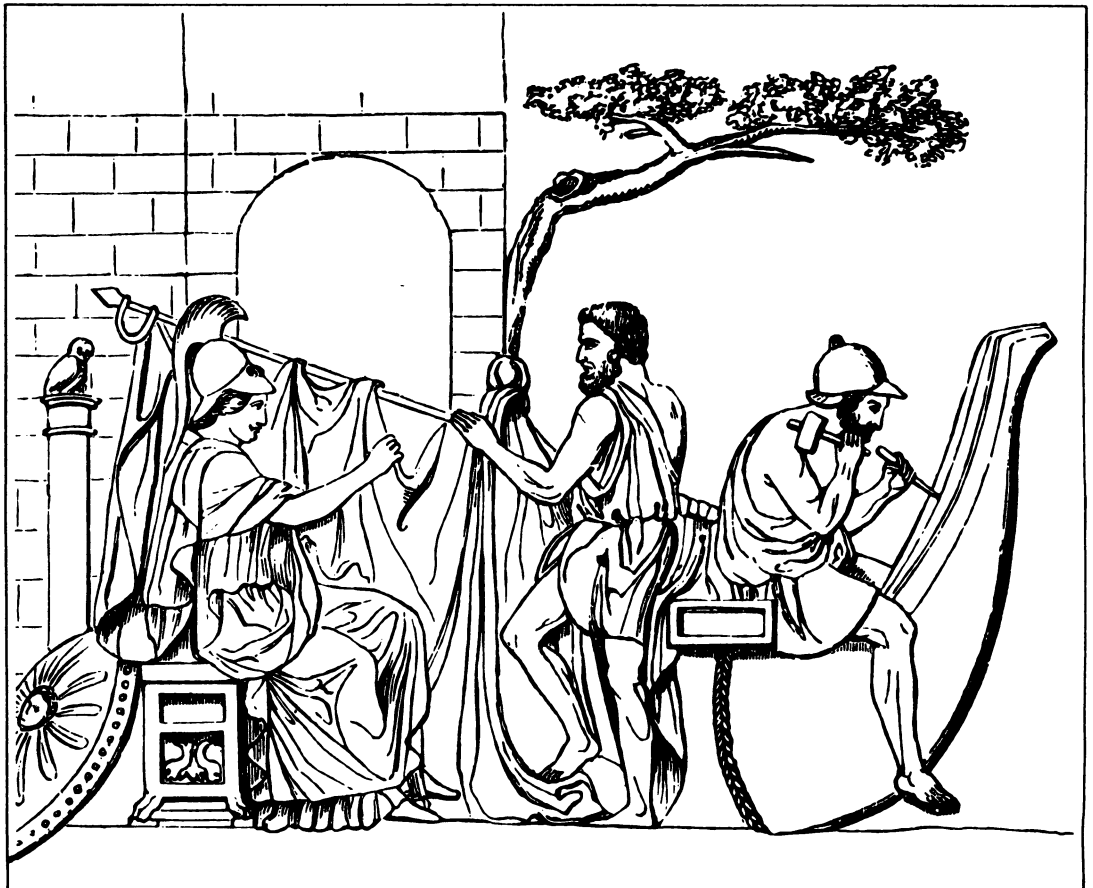

ope et consilio *Minervae* *Argo* exstruitur

armamenta navis

- A prora
- B oculus
- C rostrum
- E puppis
- F aplustre
- H remi
- I gubernaculum
- K malus
- L velum
- M antenna
- N cornua
- S pedes
- T opifera

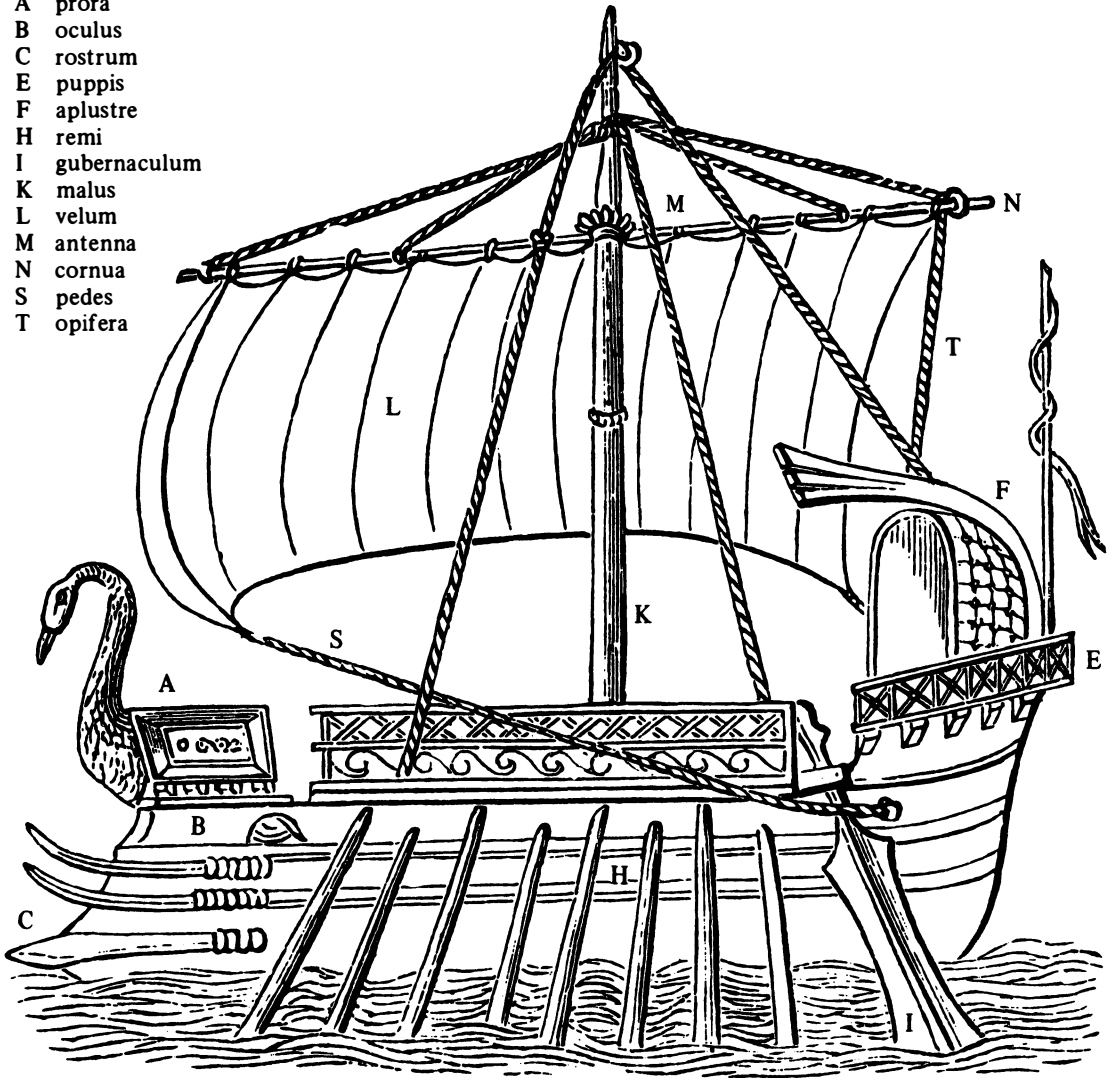

armilla –ae, f.

est bracchiale, hoc est circulus, seu anulus ex auro, argento, aliãve materiã, quo bracchia virorum et mulierum ornantur; et quo etiam milites olim virtutis causã ab imperatoribus donabantur.

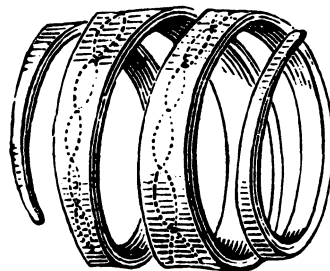

artifices et artificia

artifex est qui aliquam artem exercet. sumitur non solum pro eo, qui artem mechanicam exercet, sed etiam qui liberalem (*artes liberales*).

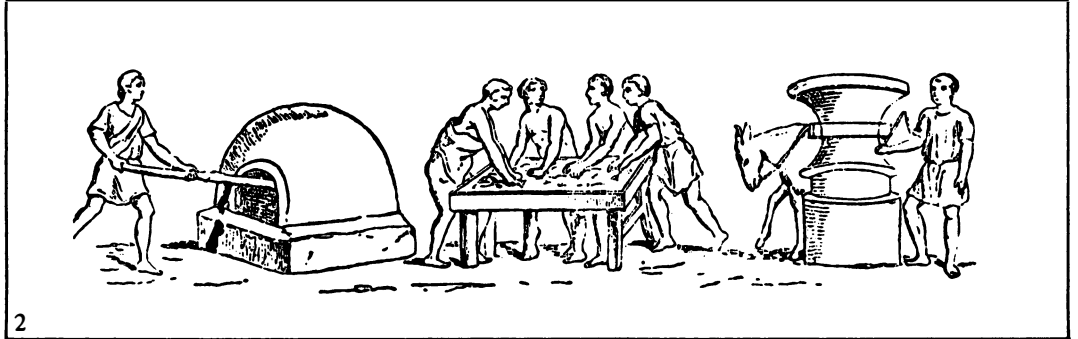

- 1, 2 pistor 4 textor 6 molinarius
3 fullo 5 macellarius 7 faber aerarius

Nepos, Att. 13:

„erant in ea familia (sc. Attici) pueri litteratissimi, anagnostae (i. e. lectores) optimi, et plurimi librarii. pari modo artifices ceteri, quos cultus domesticus desiderat, apprime boni.“

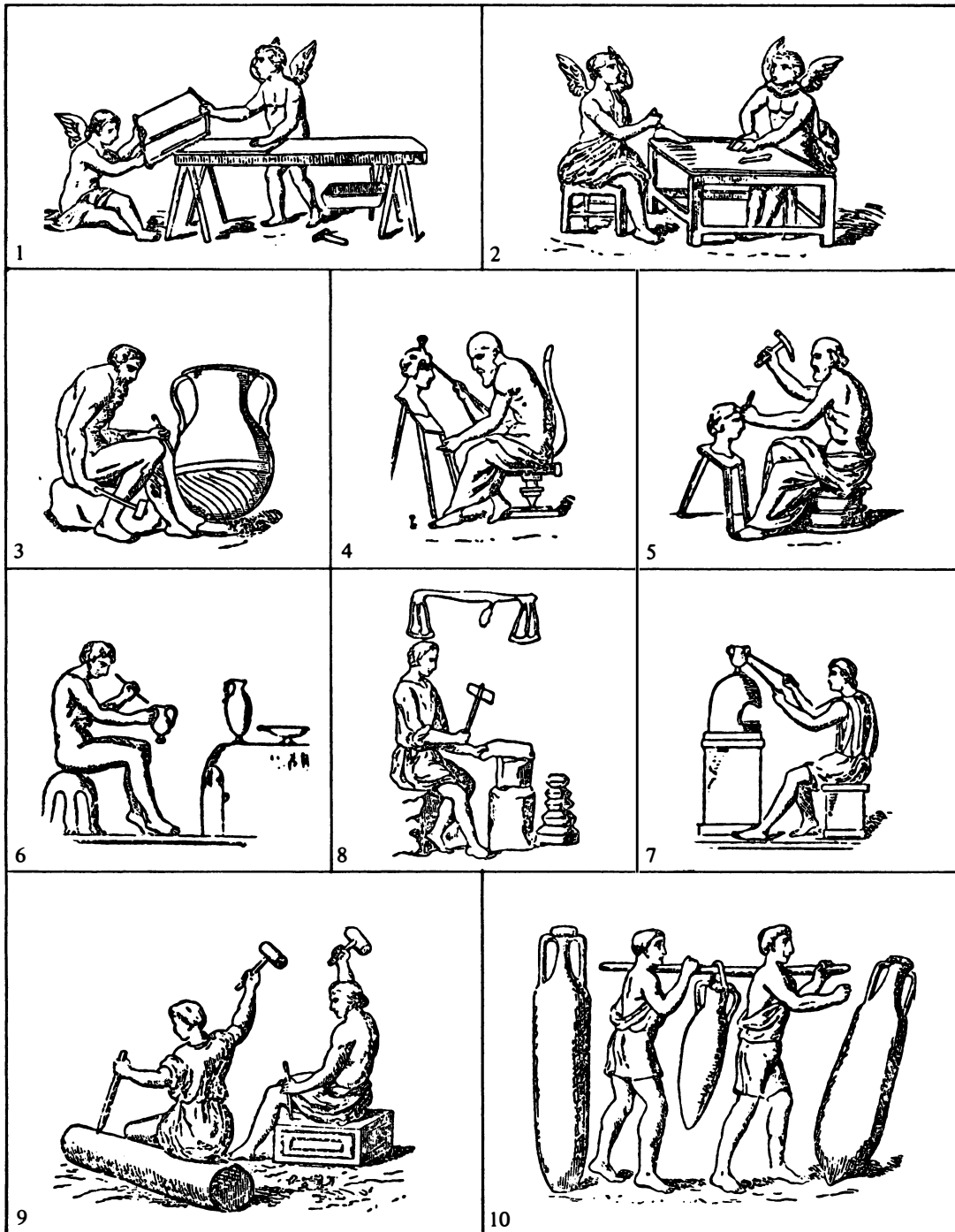

1 tignarius

3 caelator

5 sculptor

8 aurifex

10 vinarius

2 sutor

4 figulus

6/7 figulus

9 lapicida

(mercator vinarius)

arx –cis, f.

arx est locus munitissimus urbis, summus et excelsus locus, cacumen, vertex montis, moenibus, turribus aliisque propugnaculis (*propugnaculum*) munitus. Romae arx erat in colle

Capitolino; Athenis, Corinthi, in aliisque per multis urbibus Graecis arx „acropolis“, h. e. „urbs in cacumine montis sita“ nominabatur.

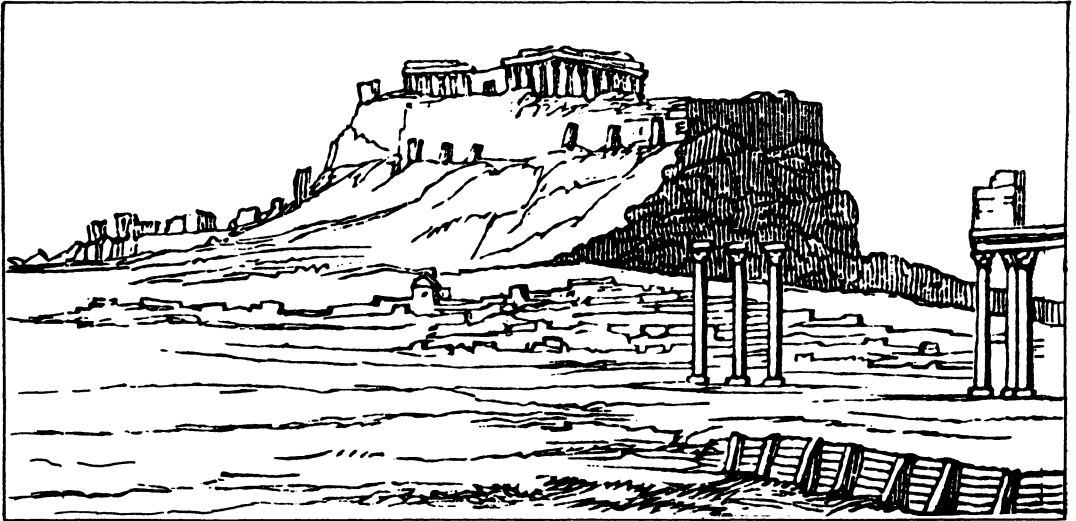

arx Athenarum

as assis, m.

- a) as erat unitas ad rem quamlibet metiendam, ponderandam, pretio aestimandam.
- b) pecunia ex aere facta, qua usi sunt Romani priore quidem tempore rudi, postea signatā: illa appendebatur *librā*. una ex parte Iano gemino, altera ex parte rostro (*rostrum*) navis aut capite Mercurii notatus erat as.

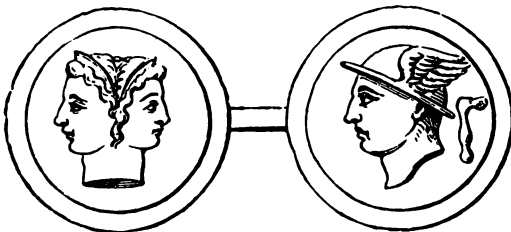

ascia –ae, f.

- a) ascia significat quodcumque instrumentum findendo, secando, fodiendo, evellendo, percutiendo idoneum.

- b) saepius est instrumentum ferreum, quo utuntur fabri lignarii ad ligna dolanda et polienda, ferrum habens latum et incurvum, manubriumque breve, ita ut tractari una manu possit.
- proverbium: „ipse mihi asciam in crus impegi“ = id, quod molitus sum, mihi ipsi perniciei fuit.

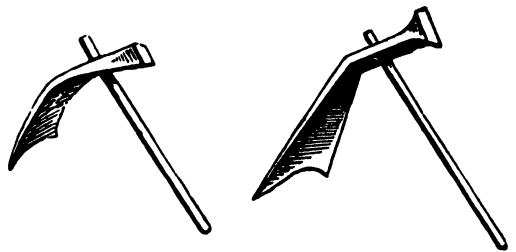

aspersio –onis, f.

est actus aspergendi, se aquā perfundendi; genus est lavationis ante sacrificia. in imagine, famula aquam aspersionis *situlā* haurit, sacerdos ramum de arbore frangit, quo aspergat dei cultores.



aspersorium est instrumentum, quo participes sacrificii asperguntur.

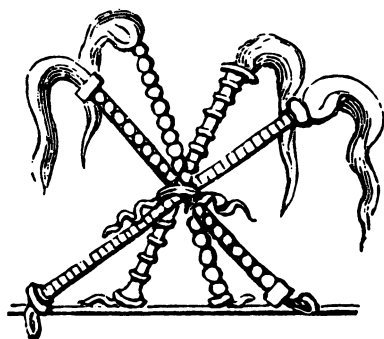

aspersoria

astragalus —i, m.

a) Graeca vox astragalus significat talum (*talus*) pedis tum in homine, tum in animalibus, quo etiam in ludis utebantur.

b) a Vitruvio pro membro architecturae, quod figurā astragalum imitatur: habetque locum in basibus columnarum, in superciliis, in coronis et alibi.

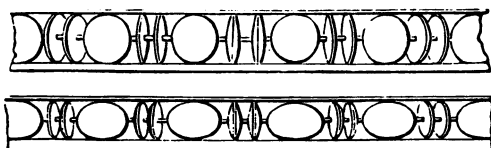

astragalus

Atlas —antis, m.

filius Aetheris et Diei; rex Mauretaniae. dux fuit Titanum, qui bellum intulerunt Iovi, a quo victus iussusque est ut in rebellionis poenam molem caeli sustineret.

Atlas etiam est nomen montis Africae, de quo Vergilius, Aen. 6, 797:

„... ubi caelifer Atlas
axem humero torquet stellis ardentibus aptum.“
Atlantes in architectura dicuntur iidem, qui telamones — figurae hominum qui columnarum vice tecta aedificiorum sustinent.



atomus —i, f.

Gr. atomos = individuus, qui sectionem non recipit. atomus est corpusculum minutissimum, quod sectionem non recipit.

Democritus (V. a. Ch. n. saeculo) primus opinatus est ex atomis mundum et omnes mundi partes factas esse, et omnia fieri, quae in mundo gignuntur: motum atomorum aeternum esse.

*** hodie vis atomica divisione aut sectione nuclei (nucleus) atomi reserata, maximam potentiam efficit.

*** pyrobolum vi atomica explodens terrificantem vim destructionis obtinet.



augur dex-
tra
manu lituum
gestans; ad
eius pedes
est avis sacra

est vir, qui auctoritate publicā sacras aves alit, custodit atque observat, et ex iis futura divinat. multus fuit augurum et usus et honos apud Romanos. tanta sacerdotio augurum erat auctoritas, ut nihil belli domique Romani gererent, nisi prius per augures deorum voluntatem explorassent. augures initio tres fuerunt, creati a Romulo, ad quinque autem a Numā creati. posterioribus temporibus saepe collegium augurum ampliatum est.

augurium, —i, n., est sacrarum avium educatio, animadversio atque ex iis rerum futurarum. divinatio. ex volatu avium capiebant Romani augurium prosperum quidem, si a sinistra parte auguris advolassent, adversum autem, si dextera. etiam e fulmine laevo laetum, e dextero triste augurium putabant.



augur Coruncanius
a Iunone Sospita
coronatus

lituus —i, m., est baculus incurvus, quo augures sedentes avibus templum designabant. lituo Romulus regiones (= templa) direxit, tum, cum urbem condidit.

est initium diei „quo aer ab igne solis tum aureo aurescit“ ut ait Varro, L. L 7, 83. in fabulis Aurora est filia Hyperionis et Aethrae; mater Memnonis, qui ab Achille ante Troiam occisus est, quem mater cottidie matutino rore deflare dicitur.



in imagine e vase Graeco sumptā Aurora quadrigam ducit praeunte Phosphoro. ambo nimbo (nimbus) praediti sunt. polypus, piscis et delphinus mare indicant, e quo Aurora emergit.

est res quaecumque, circa quam alia res vertitur, speciatim est lignum illud teres, circa quod rota currūs vertitur.

item axis dicitur linea imaginaria, quae ab uno caeli cardine (cardo) seu polo, per centrum terrae transiens, in alterum terminatur: circa quam universa mundi machina circumvolvi dicitur.

Cicero, de natura deorum, 1, 20, 52:

„mundus versatur circum axem caeli admirabili celeritate.“

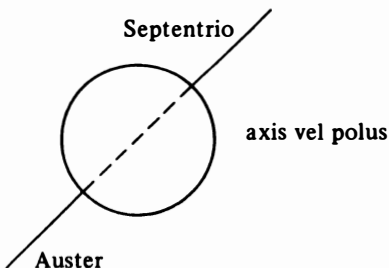

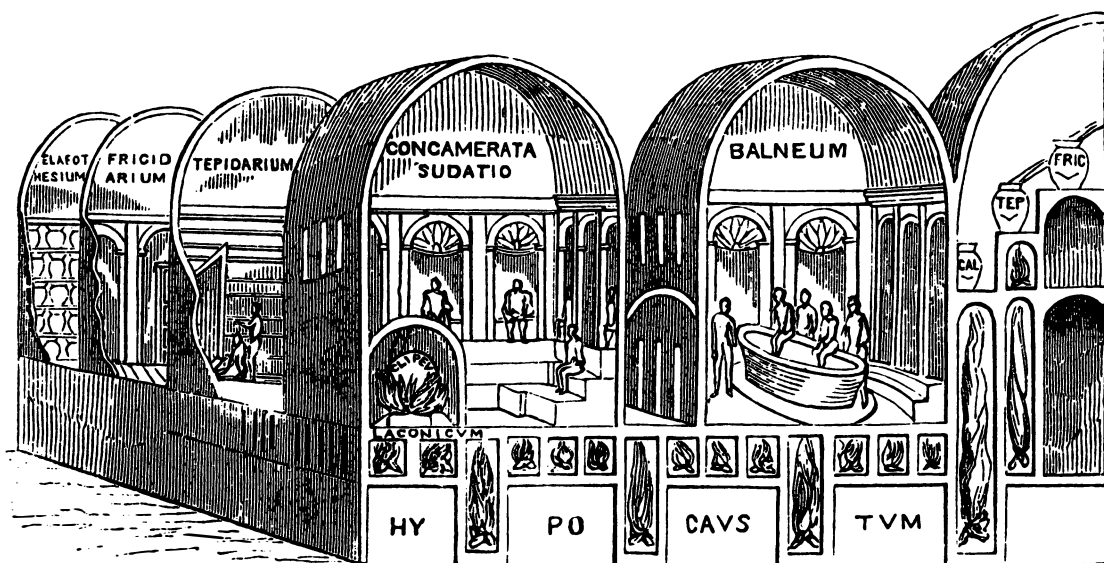

(imago e Thermis Titi imperatoris proveniens)

in *hypocausto* ignis ad calefaciendas concamerationes superiores alebatur. **balneum** (**calidarium**) conclave erat magnum, in quo ingens *labrum* videmus, cuius orae latiori, qui se lavabant, insidere poterant. **concamerata sudatio** sudantibus erat destinata. iunctum huic camerae est **laconicum** tamquam *fornax* immittendo calori aptum (idem erat, quod hodie Sauna Fennica nominatur). pone sudationem **tepidarium** videmus, in quo tepidior aer inter calidum frigidumque medium quasi tenebat. tepidario haerebat **frigidarium** et **apodyterium** (= vestiarium, *vestiarius*), in quo vestes deponere solebant.

primo in frigidarium intrabatur, ubi veste deposita corpus defricabant; hinc ad tepidarium transitus erat, unde post aliquantum temporis in sudationem procedebant; ex hac in balneum tandem calidum (i. e. in calidarium) perveniebant. Eodem ordine regredientes post lotionem in sudationem denuo intrabant, ibidemque aliquantum temporis commorati ad tepidarium et ex hoc ad frigidarium pergebant, ubi vestes induebant.

saepe in frigidario **baptisterium** erat, ampla piscina ad natandum. (apud ecclesiasticos scriptores speciatim baptisterium erat locus, in quo baptismi sacramentum solemniter administrabatur).

thermae balnea publica erant, quae in omnibus oppidis urbibusque imperii Romani magno sumptu aedificabantur. sed etiam in domibus villisque rusticis balnea privata eadem ratione instituta erant.

balteus —i, m.

a) cingulum militare, ab humero dextro sub sinistram brachium descendens, transversum pectus cingit.



balteus militaris (a)

b) balteum dixere zonam, qua ephippia (*ephippium*) equorum dorso adstringuntur, vel potius lorum pectorale, quod bullis (*bullae*) aureis ornari solet.



balteus equi (b)

c) apud astronomos est *zodiacus*.

Manilius, 1, 679:

„sed nitet ingenti stellatus balteus orbe.“

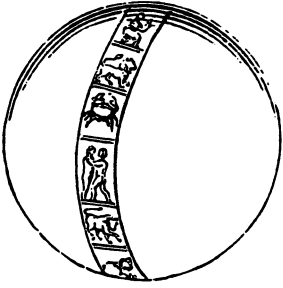

balteus zodiaci (c)

d) baltei in theatris dicuntur praecinctiones, quibus ordines spectatorum ab aliis separabantur.

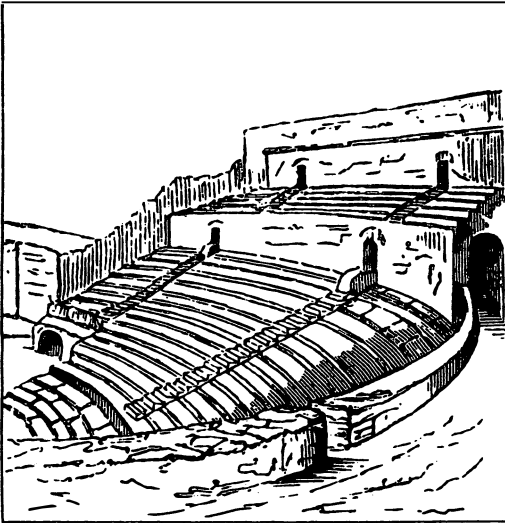

balteus in theatro (d)

baptisterium —i, n.

est *piscina* frigida in frigidario (*frigidarium*) balnei (*balneum*), ubi post sudationem summersi sunt Romani. baptisterium a verbo Graeco „baptizo“, „submergor“ nominatur. in piscina baptisterii Christiani sacramentum baptismi administrabatur, unde primae ecclesiae Christianae etiam baptisterio, aedificio rotundo cum piscina, praeditae erant.

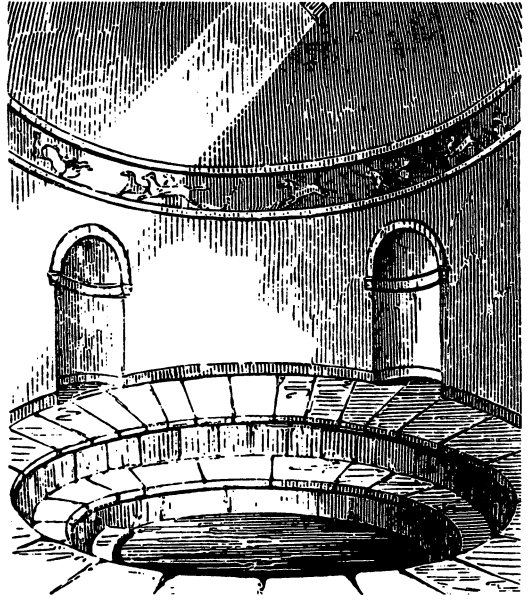

basilica —ae, f.

a) proprie domum regiam significat Graece.

b) quia vero regum aedes ampliores esse solent

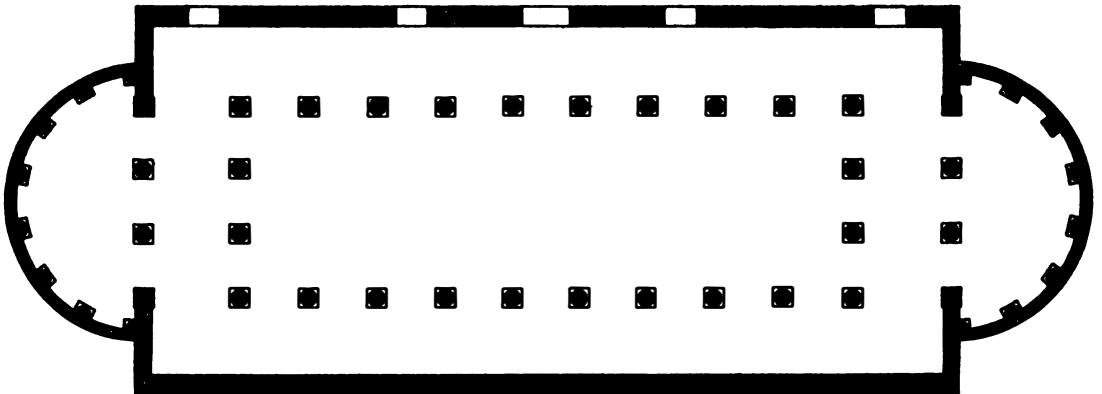

ichnographia basilicae Augustae Rauracorum prope Basileam sitae

atque ornatiores, Latini aequae ac Graeci basilicas appellaverunt aedes publicas spatiosis membris et ambulationibus instructas porticibusque (*porticus*) amplis saepe circumdatas. Saepe basilicae erant aedificia ad populi com-

modum facta, ut haberet, quo convenire posset ab aëris iniuriis munitus et negotia sua sub tecto agere. Hic etiam saepe iudicia exercebantur.

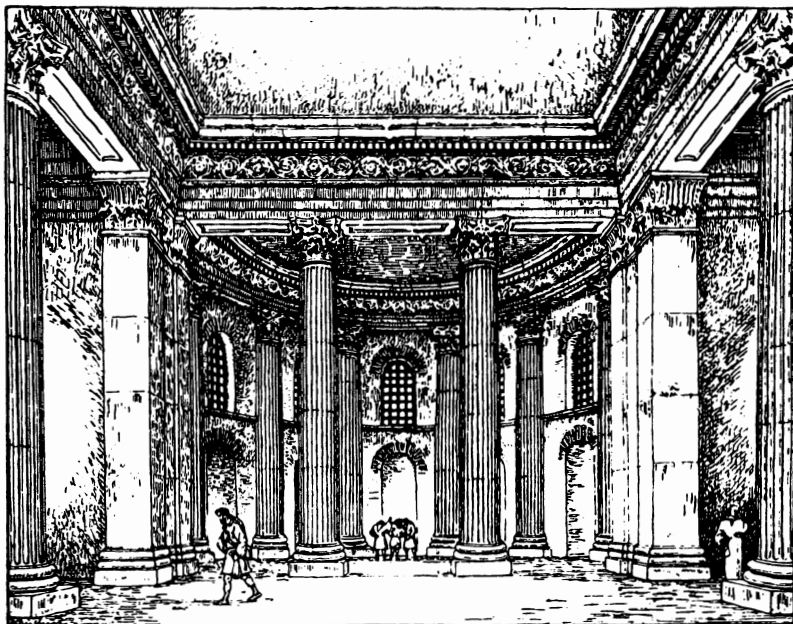

interior pars basilicae
versus apsidem

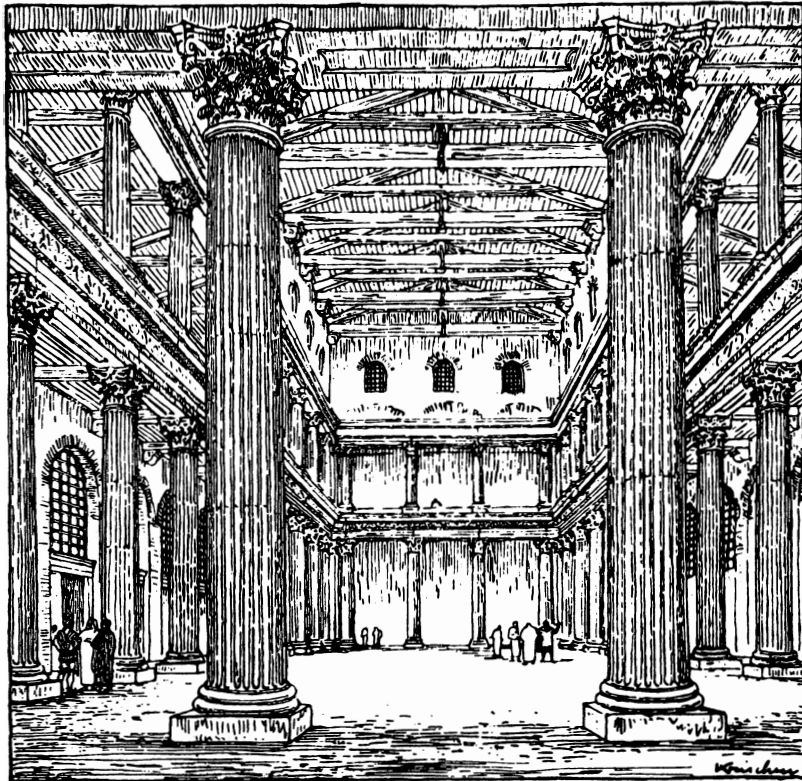

interior pars basilicae
(reconstructa) Augustae
Rauracorum

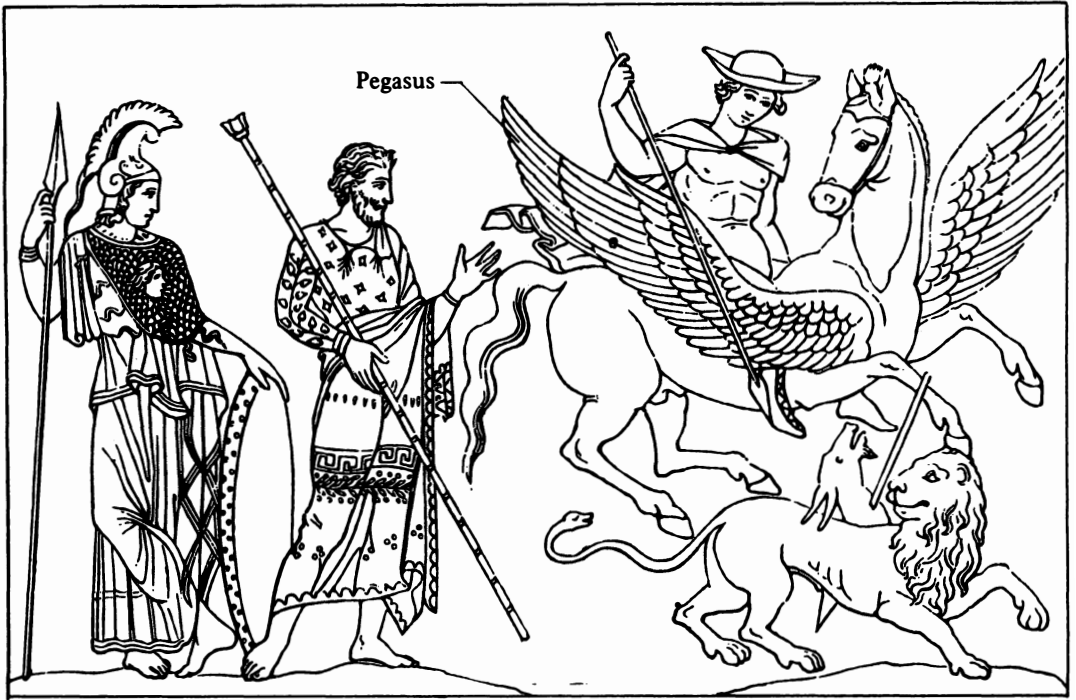

filius Neptuni et Eurynomes, Nisi filiae, rex Ephyrae, sed regno spoliatus a Proeto, Argivorum rege. apud illum eius iussu aulicam vitam peregit. corporis pulchritudine, simul et praeclarissimis maximisque virtutibus excelluit. cum a Sthenoboea, uxore Proeti, interpellatus esset, veritus hospitalis Iovis iram, lascivam feminam reppulit. quare exardescens repulsa mulier, apud virum innocentem hospitem accusavit, qui hospitii iure motus illum domi interficere non sustinuit, sed, datis codicillis, ad Iobatem, socerum in Lyciam misit. lectis ergo codicillis, Iobates in ultionem criminis multis periculis eum obiecit, quae facile superavit. postremo ad interimendam *Chimaeram* missus est; quem etiam laborem, nactus Neptuni beneficio Pegasus, equum alatum, summa cum laude superavit. postea vero Bellerophontes, felici rerum successu elatus, cum in caelum evolare cum Pegaso conaretur, ab Iove equo excussus decidit in terram.

bidens —dentis, m.

est, qui duos habet dentes. est etiam instrumentum rusticum ferreum, duobus velut dentibus una ex parte instructum, aptumque ad terram fodiendam.

bipalium —i, n., est instrumentum palae instar latum, et ligneo oblongo manubrio praefixum ad terram versandam et fodiendam.

falx —cis, f., est ferramentum incurvum ad varios usus in re rustica, quo segetes metuntur, quo faenum secatur; alio genere falcis arboreas putantur.

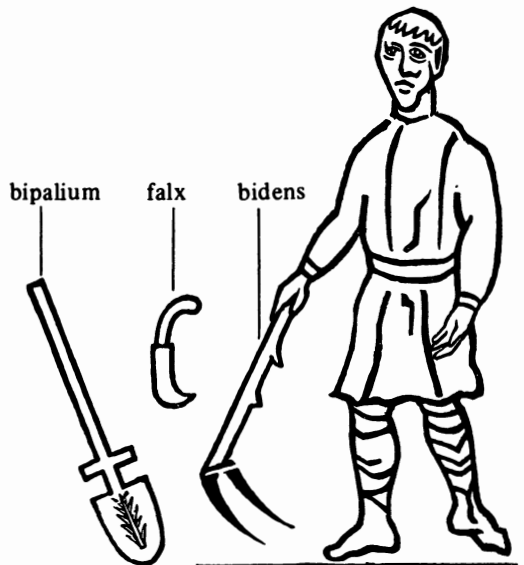

bigae –arum, f. pl. (vel biga, –ae)

a) bigae sunt duo equi iugo coniuncti.



b) bigae sunt currus duobus equis iunctus; (*quadrigae*).



nummus **bigatus** est nummus antiquissimus, denarius argenteus, qui bigis ornatus est.



bisellium –i, n.

bisellium erat sella plicabilis, latior, et duorum capax, quamvis unus tantum in ea sederet. accipitur pro sella splendida atque honesta, et honoris causa praeclaris viris concedi solita atque Augustalium in municipiis et coloniis propria, ut publice in ea sederent, in ludis, in teatro, in foro, in curia, ea ratione, qua Romanis magistratibus *sella curulis*, cui simillima erat.

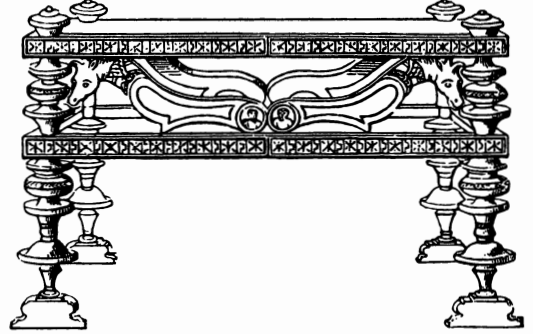

bracae –arum, f. pl.

sunt vestis barbarorum propria, ut Persarum, Medorum, Sarmatarum, Gallorum, Germanorum, quae non femora solum, sed etiam crura, immo et ventrem contegit. a Romanis, sicut neque a Graecis, diu adhibita non erat. Posterioribus tamen temporibus etiam



ad Romanos transiit. Milites Romani, qui in Gallia et Germania vivebant, hanc vestem, bracas Gallicas, usurpare coeperunt frigoris vitandi causā, ut etiam in opere caelato columnae Marci Aurelii videmus.

Ovidius de barbaris quibusdam, *Trist.* 5, 7, 49: „pellibus et laxis arcent mala frigora bracis.“

bucina –ae, f.

bucina est instrumentum recurvum, in quod insufflando sonos edimus. bucina signis dandis inservit.

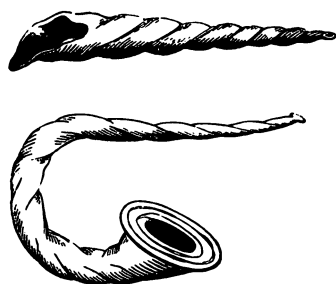

bucinator –oris, m.

est qui bucinā canit ad signa danda. imago bucinatorem in navi signa canentem monstrat.

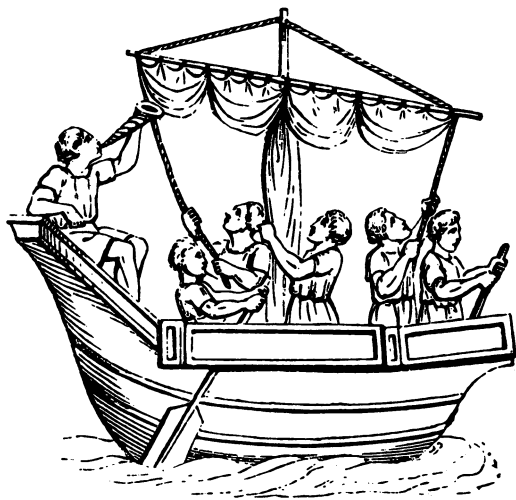

bullā –ae, f.

a) est tumor globosus in aqua aut aliquo alio liquore excrescens, cum bullit aut spumam facit, et repente evanescens.

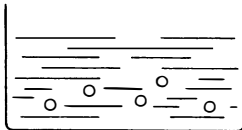

b) per similitudinem dicuntur bullae clavorum (*clavus*) capita, quibus ditiorum fores exornari solent, item quae cingulis (*cingulum*) et balteis (*balteus*) infigi.

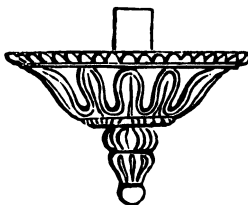

c) praecipue bullā aurea dicta est *insigne* quoddam, quod a pueris Romanis e collo ante pectus loro suspensum gestabatur in *signum* ingenuitatis et fortunae. tempore sumendae togae virilis bullam una cum toga praetexta deponebant et Laribus (Lares) donabant sicut puellae Veneri pupas (*pupa*) suas.

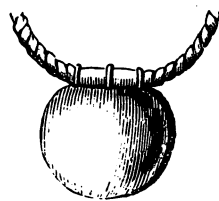
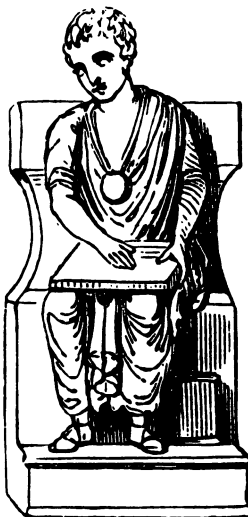

bullā aurea

puer bullatus

d) ** bulla est sigillum aureum pontificis Romani; ideoque etiam scripta bullis aureis sigillata „bullae“ nominabantur.

Byzantium –i, n.

est urbs Thraciae ad Bosporum in promontorio (*promontorium*) inter sinum, qui „chrysoceras“ = „cornu aureum“ dicitur et propontidem sita; post Constantinum Constantinopolis nominata est; hodie „Stambul“ appellata. hoc nomen ortum est ex verbis „eis ten polin“, quae Graeci accolae,

cum urbem adirent, usurpabant. Byzantium colonia Graecorum condita est anno a. Ch. n. 658 situ pulcherrimo ac tuto et commerciis (*commercium*) quam maxime idoneo. memorabile est eius *templum* rotundum Stae. Sapientiae (Hagia Sophia) dedicatum, quod imagine illustratur.

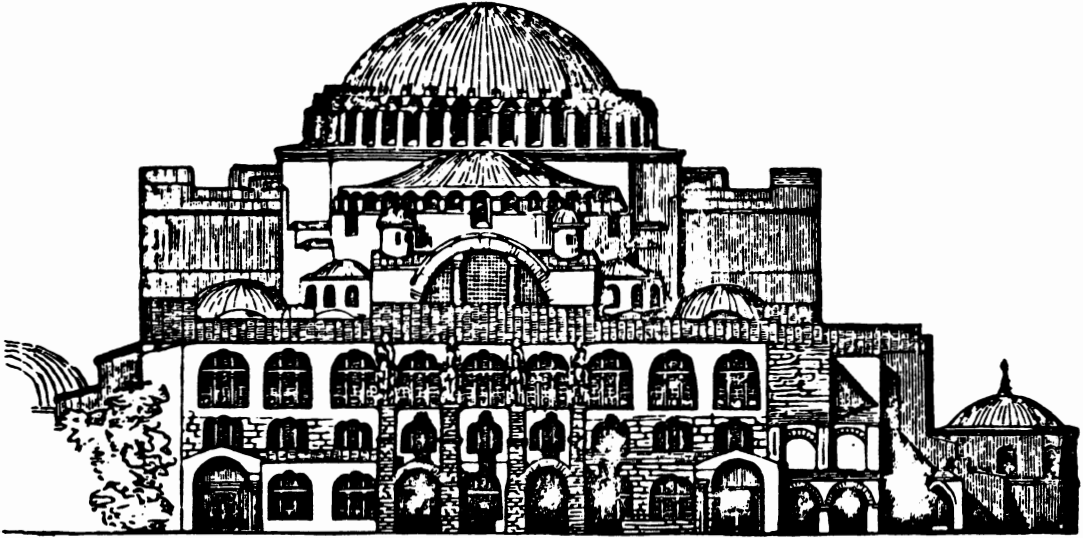

cādūceus –i, m. (aut –eum, –i, n.)

caduceus est virga Mercurii duobus serpentibus illigata.



Mercurius talaribus (*talaria*) caduceoque munitus

caducifer –i, m.

est qui caduceum (*caduceus*) gestat; epitheton Mercurii.

Ovidius, *Met.* 8, 617:

„venit Atlantiades (= Mercurius) positus caducifer alis.“

cadus –i, m.

cadus est vas condendo servandoque vino praecipue aptum.

cadi, ut dolia (*dolium*), ex fictili materia facti sunt.

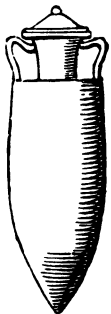

calcar –āris, n.



calcaria Romana

calcar est stimulus ferreus calci (*calx*) alligatus, quo equos pungimus et incitamus, ut docet Isidorus, *Orig.* 20, 16, 6:
„calcaria dicta, quia in calce hominis ligantur, id est in pedis posterioris parte, ad stimulandos equos, quibus aut pugnandum est aut currendum.“
formula: concitare equum calcaribus. translate dicitur pro stimulo et incitamento.

Cicero, *de orat.* 3, 9, 36:

„in altero calcaribus, in altero frenis uti.“

id. *ad Att.* 6, 1, 12:

„alter (puerorum) frenis eget, alter calcaribus.“

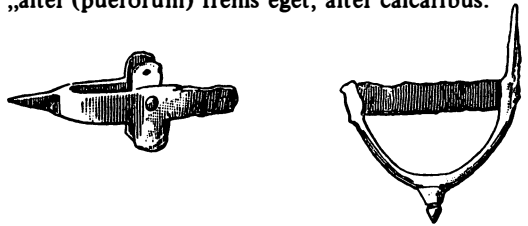

calcator –oris, m.

qui calcat, et speciatim qui calcat uvas. (vide imaginem).

calcatorium est locus in *cella* vinaria, in quo uvae calcantur.

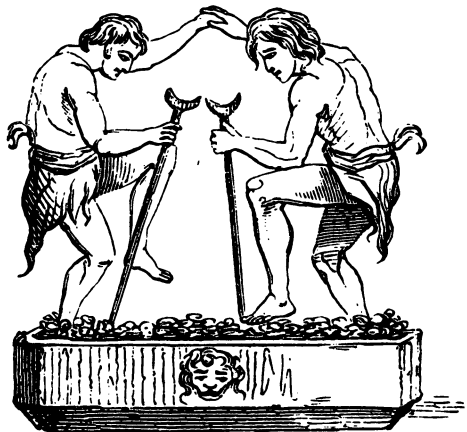

calco –as, –avi, –atum, –are

est aliquid calce et pede premere. **calx** (calcis) f. est inferior posteriorque pars pedis. calcantur uvae in torculario (Cato, RR. 1/2) (*torculum*).

calendarium –i, n.

a) Latini hoc nomine appellant librum, in quo faeneratores perscribebant nomina eorum, quibus pecuniam faenori dederant et pensionis solvendae quantitatem. quoniam Kalendis pecunia faenebris collocari solebat, et Kalendis itidem, vel Idibus eius usura solvi.
 b) **posterioribus temporibus calendarium dictum est etiam liber, in quo anni, mensium ac dierum ac lunarium mutationum ratio perscribitur, vide specimen calendarii ruralis in illustratione apposita.



caliga –ae, f.

caliga est calceamentum militare, quo Romani milites gregarii utebantur, constans *soleā* coriacea, quae ferreis plerumque clavis (*clavus*) muniebatur habebatque ligamenta plura, quibus tum superiori pedis parti, tum imae tibiae

circumdatis ligabatur; **deminutivus**: caligula. hinc cognomen C. Caesari filio Germanici et Agrippinae: Caligula.

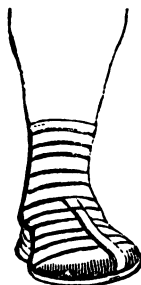

calix –icis, m.

a) vas ollae formam habens.
 b) vas coquendis cibis aptum.
 c) item est poculum, ad calidam praecipue bibendam, ex terra vel aliquo metallo constans, nullis fere pedibus, mediocri altitudine, rotundum ac latum.



camera –ae, f.

est tectum incurvum in modum testudinis (*testudo*), tectum in modum crucis arcuatum sive ipsa tecti curvatura. camera differt a fornice (*fornix*) in eo, quod camera significat totum tectum fornicatum, fornix vero de singulis etiam camerae arcubus dicitur; quamquam hoc discrimen perpetuum non est.

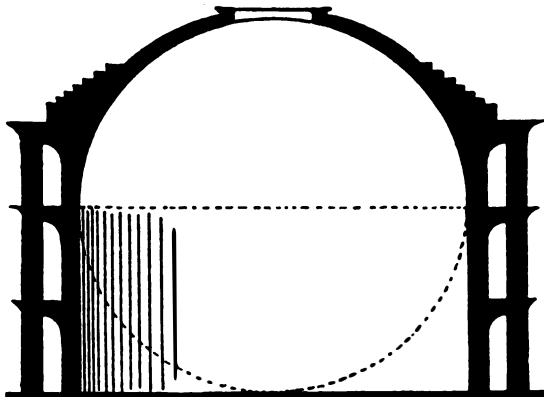

Campania –ae, f.

est regio Italiae australis, se protendens a Latio usque in Lucaniam, limites habens inter Latium, Samnium, Lucaniam et mare inferum, a monte Massico ad Silari ostium.

urbes et oppida:

Capua, caput Campaniae (adi. Campanus), Neapolis, Cumae, Baiae, Puteoli, Herculaneum,

Pompeii, Stabiae, Surrentum, Salernum et alia.
viae: Via Appia (Furcae Caudinae), Via Campana, Via Popilia, Via Domitiana.

montes: mons Massicus, Furcae Caudinae, mons Vesuvius, mons Lactarius.

flumina: Volturnus, Sarnus, Silarus.

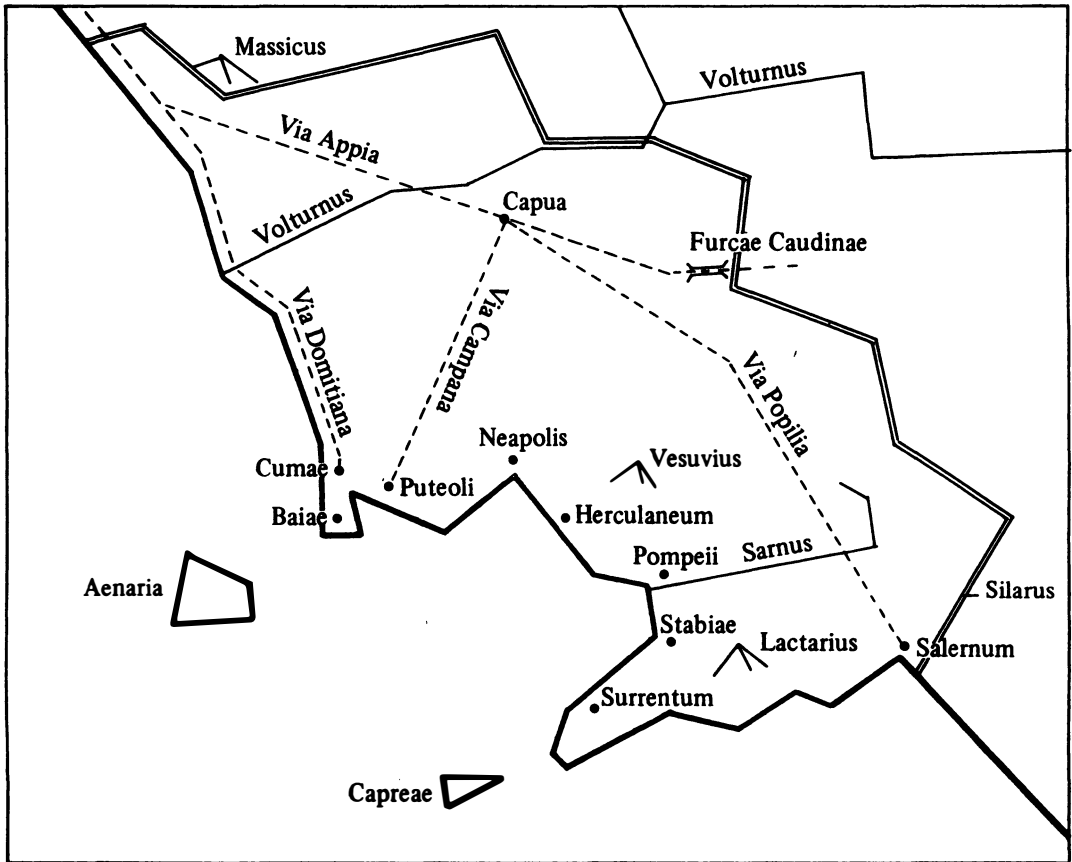

cancelli –orum, m. pl.

cancelli sunt saeptum ex rectis et obliquis lignis aut ferramentis, modicoque intervallo distinctis contextum, quo fenestrae, ianuae, scaenae, tribunalia muniri eorumque aditus praeccludi solent.

Columella, R. R. 8, 17, 6:

„ravis, per quos exundat piscina, praefigantur aenei exiguis foraminibus cancelli, quibus impediatur fuga piscium.“



candelabrum –i, n.

candelabrum est instrumentum, in quo candelae infiguntur. translate etiam candelabrum dicitur instrumentum illud, quod non candelas habet, sed oleum continet ad illuminanda cubicula.

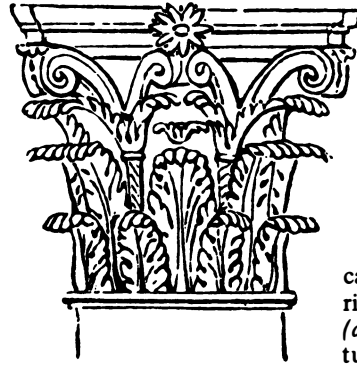
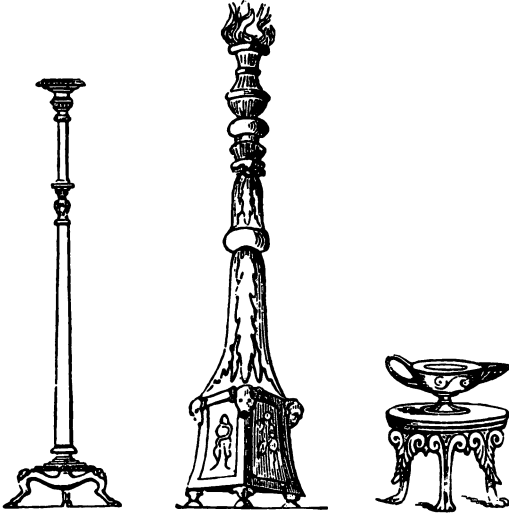

capitulum Corinthium acanthis (*acanthus*) ornatum

capsa –ae, f.

capsa est *arca*, cista, scrinium, ex ligno vel metallo aliquo, in quo praecipue volumina librorum et tabulae et litterae reponebantur. deminutivum: capsula, –ae, f., parva capsula ad libros et chartas reponendas. formula dicendi: „homo totus de capsula“ dicitur, qui summo-pere munditiis studet, et in eo totus est, ut exquisito cultu compositus ornatusque pareat. Seneca, epist. 115, 2:

„nostri complures iuvenes, barba et coma nitidos, de capsula totos: nihil ab illis speraveris forte, nihil solidum.“

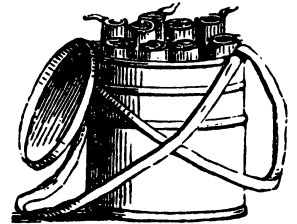
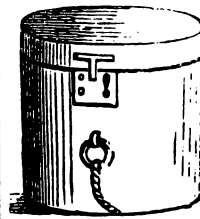

capitulum –i, n.

est pars superior *columnae*.

Vitruvius, de architectura 4, 1, 1:

„columnae Corinthiae, praeter capitula omnes symmetrias habent ut Ionicae, sed capitulorum altitudines efficiunt eas pro rata excelsiores et graciliores.“

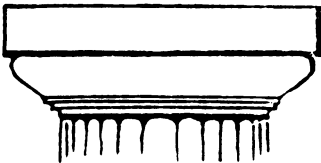

capitulum Doricum

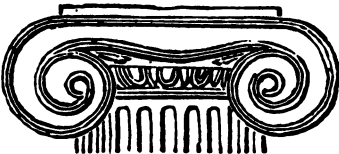

capitulum Ionicum

cardo –inis, m.

a) in machinationibus lignum aliquod in cavum seu foramen alterius immittitur, ut versari possit, cardo dicitur.

speciatim cardo est fulcimentum illud, cui fores incumbunt et vertuntur. cardines apud veteres plerumque infixi erant in superiore et inferiore ostii parte, hoc est in superno et inferno limine. (*limen*)

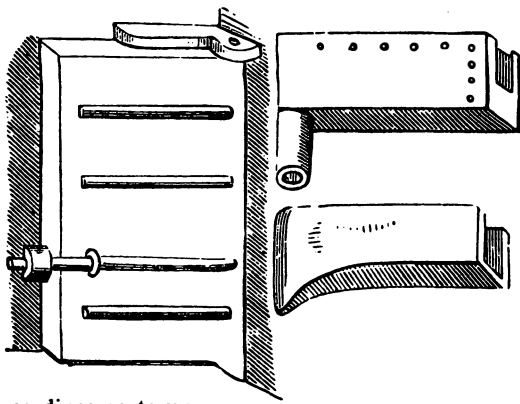

cardines portarum

b) in re astronomica et mathematica cardo est *axis* caeli, praecipue cardo dicitur *polus* septentrionalis, hinc in re agraria cardo est via, fossa, *limes* a meridie ad septentrionem ductus, quem admodum *decumanus* limes est, qui ab oriente ad occidentem. hae lineae etiam in castris et oppidis condendis ducuntur et vias principales castrorum vel oppidi definiunt. (*castra*)

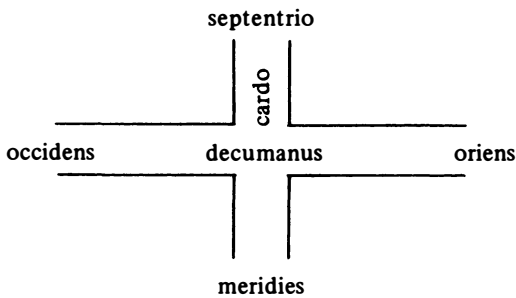

carpentum –i, n.

carpentum est genus vehiculi, cuius forma varia. carpento in itineribus extra urbem raro admodum sed Romae plurimum in itineribus urbis matronae usae sunt.

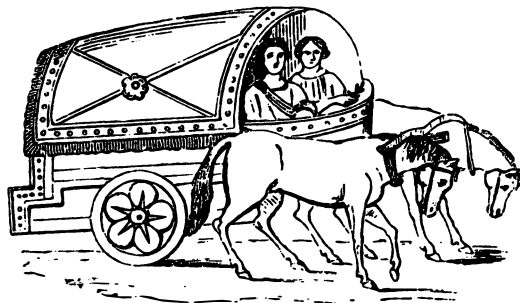

Caryatides –um, f.

Caryatides sunt statuae virginum quae pro columnis tectum aedificii sustinent. (*Atlantes*). hae virgines Caryatides a loco *Caryae*, oppido in Peloponneso sito, nuncupatae, calathiscos (= corbes) capitibus portant, saltationem in honorem Artemidis deae celebrabant.

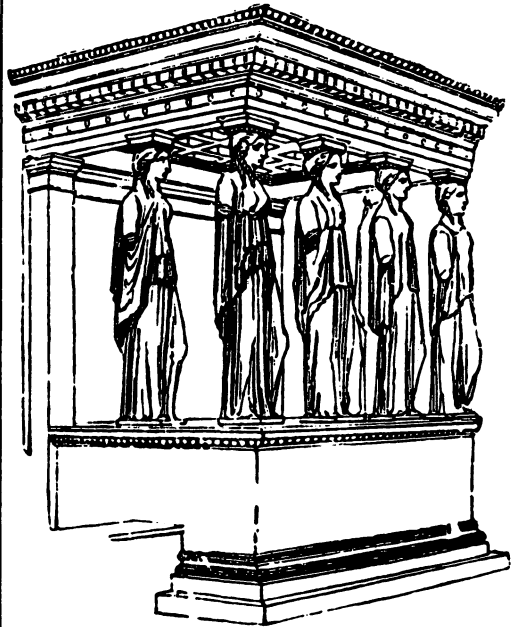

casa –ae, f.

casa est domus vilis, tugurium, mapale, aedes deteriores et male constructae, cuiusmodi sunt, quas rustici et pauperes habitant.

Seneca, Ep. 90, 10:

„furcae utrimque suspensae fulciebant casam: spissatis ramalibus ac fronde congesta et in proclive disposita, decursus imbribus quamvis magnis erat. sub his tectis habitabant securi. culmus liberos texit: sub marmore atque auro servitus habitabat.“

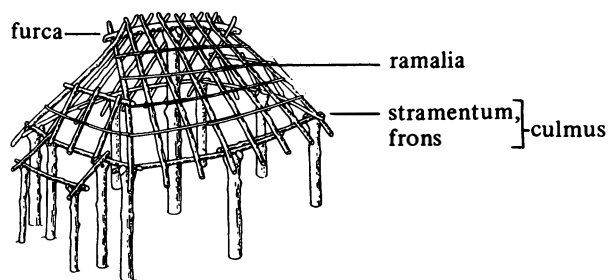

castellum –i, n. deminutivum a „castrum“

a) castellum est locus militari opere munitus exstructo aggere, vel muro cum fossa, quasi parvum castrum.

b) translate castellum est locus operibus munitus ac tutus.

c) castellum etiam nominatur receptaculum aquarum in aquaeductibus (*aquaeductus*), ex quo aqua ex communi ductu per fistulas in varia loca distribuitur: unde et „*dividiculum*“ dictum est; „aquam e castello ducere“.

d) eodem nomine appellatur *labrum* amplum in summo rotae aquariae (*rota*), in quod influit aqua ex modiolis (*modiolus*), cum ad summum elati invergi coeperint. (Vitruvius, 10, 4, 3) castellum aquarum

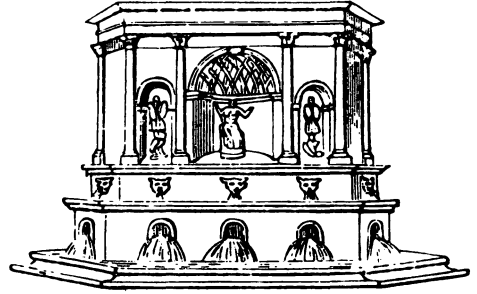

Castor et Pollux

sunt Lacedaemonii, Iovis et Ladae, uxoris Tyndarei filii dicti, ex eodem ovo eodemque partu editi, fratres Helenae, quam a Theseo raptam et Aphidnae custoditam liberaverunt; Dioscuri, i. e. filii Iovis nominabantur. equorum tutores erant et saepe equis vehuntur, de quibus Cicero, Nat. Deor. 2, 2,6:

„apud Regillum, in nostra acie Castor et Pollux pugnare visi sunt.“

Castor et Pollux alternā morte ab inferis redeunt seu alternatim vivunt.

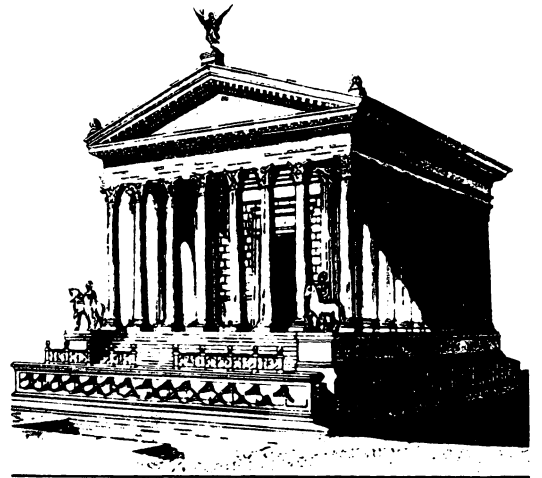

templum Castoris et Pollucis
Romae aedificatum



sacrificium Dioscuris offertur

castra –orum, n. pl.

sunt locus, in quo exercitus cum in expeditione est, subinde consistit et vallo (**vallum**) fossaque munit, tentoria (**tentorium**) figit, quietem capit.
formulae: castra locare, castra movere.

e castris **statis** saepe oppida eiusdem ichnographiae fiebant, ut etiam in aliquot hodiernis oppidis cernitur, ex. gr. Xanten.
castra **cardine** et **decumano** in quattuor **quadrantes** dividebantur.

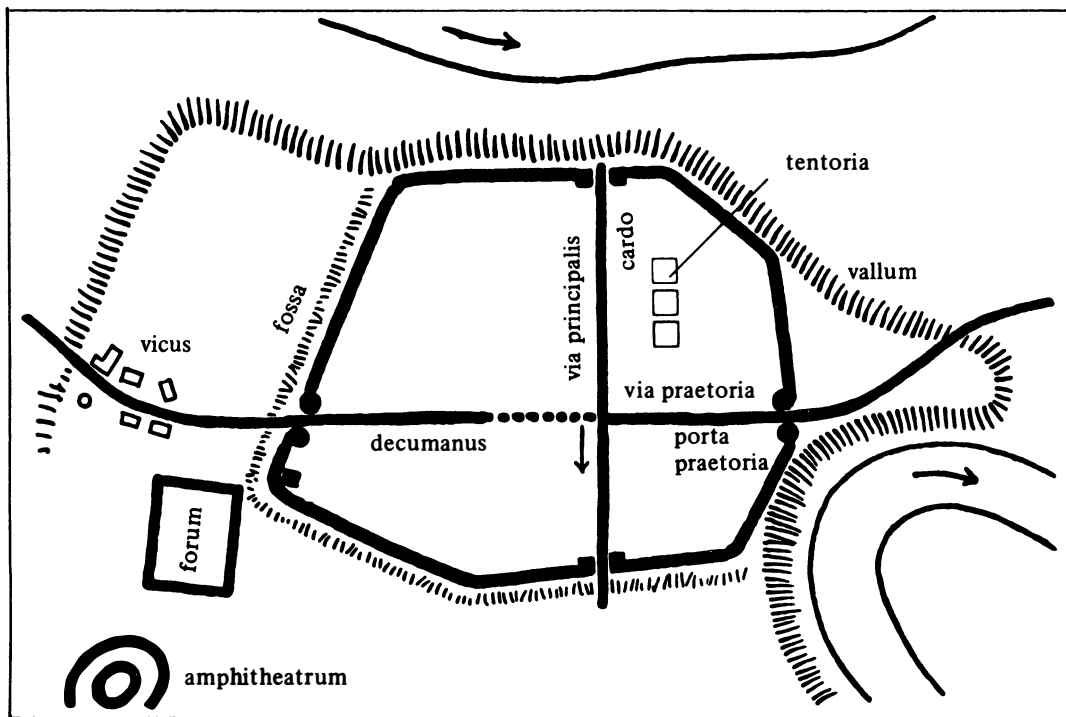

castra legionis Vindonissae sita

***catacumba** –ae, f.

catacumba est sepulcrum arcuatum, subterraneum, seu potius *fornix*, hominibus sepelien-

dis apta. temporibus persecutionum saepe primi Christiani his in locis latuerunt.

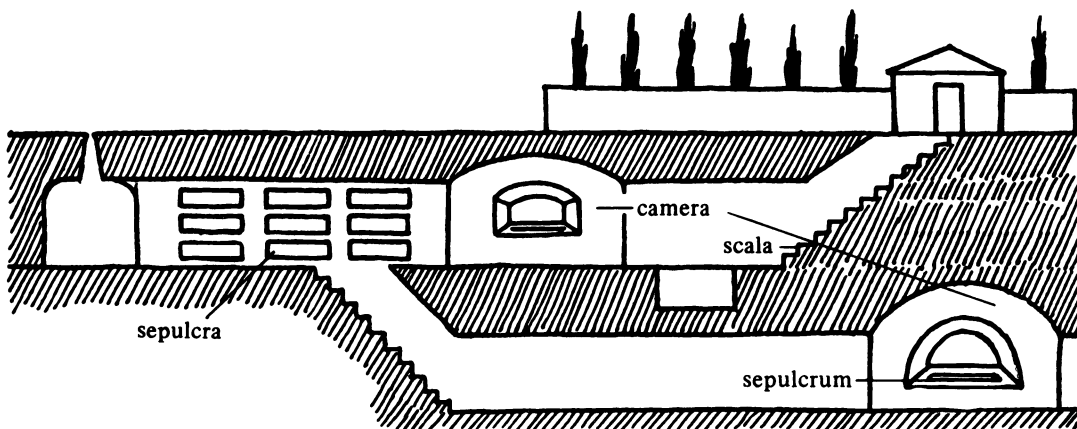

catapulta –ae, f.

est genus machinae militaris, quā sagittae et tela magno impetu longoque spatio iaciuntur.

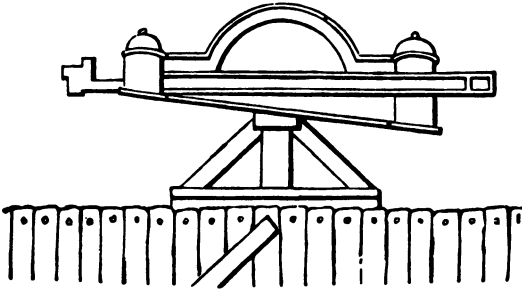

catapulta

cataracta –ae, f./cataractes m.

significat praecipitem eruptionem et descensum:

a) cataracta est locus angustus, praeruptus, et praecipitium in flumine, ubi aqua illisa et refracta magno impetu ruit, qualis est in Nilo eo loco, quae Catadupa ab incolis appellantur.

b) sunt etiam cataractae claustra in fluminibus arte facta ad aquarum impetum temperandum vel ad aquas colligendas.

c) item genus est militaris obicis in urbium portis, qui funibus aut catenis cum aperitur, in altum tollitur, et cum opus est, iis repente solutus, citissime decidens, momento temporis aditum claudit.

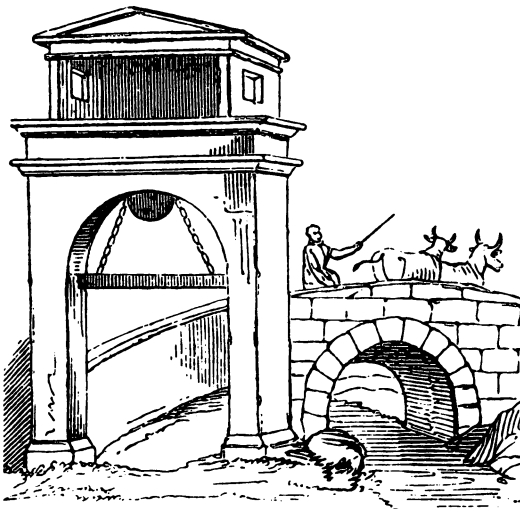

cataracta in aditu pontis, cui inferior pars deest

catenarius –i, m.

est qui catenā ligatur, ut canis ad fores domūs custodiae causā.

imago repraesentat canem catenarium domūs Pompeianae cum inscriptione: cave canem!

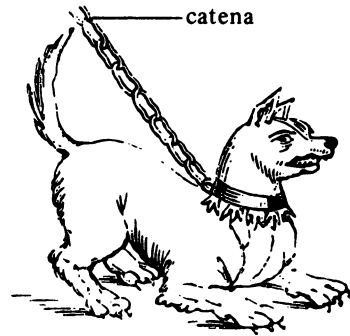

cathedra –ae, f.

est Graeca vox, quae proprie significat sedile, sellam (*sella curulis*).

a) speciatim sumitur pro sella molliore et delicatior, qua utebantur mulieres et delicati etiam homines.



cathedra mulieris in vase Graeco

b) dicitur etiam pro sella magistrorum et professorum.

**ponitur etiam pro sella et munere episcopali: ecclesia cathedralis est sedes episcopi.



cathedra professoris

caupo –onis, m. (cōpo)

significat quemcumque mercatorem et institorem, praecipue esculentorum poculentorumque venditorem.

caupona, –ae, f.

est taberna, ubi mercatores res vendunt, et praecipue ubi caupones vinum et cibos vendunt ac peregrinos excipiunt, ut in figura nostra.

cauponari:

est cauponam exercere, e quo verbo verbum germanicum „kaufen“ derivatur.



lanius in laniēna: e pertica pendunt caput vituli, perna aliaeque carnes

caupona Pompeiana

haec imago Pompeiana interiorem partem cauponae monstrat. de tecto pendunt tomacula et carnes in retibus e pertica:



cavea –ae, f.

a) cavea significat cavum et vacuum, quod multis constat circulis inter se divisus ac distinctis.

b) accipitur pro loco concluso aut saepto, in quo bestiae asservantur.

c) accipitur etiam pro quodam ianuae versatilis genere.

d) item de saepto (saeptum) ex lignis et spinis, quo tenerae arbores a pecudum iniuriis muniuntur.

e) praeterea dicitur de loco, in quo sedet populus in theatris (*theatrum*), quia concavus est et rotundus, tamquam cavea.



cella –ae, f.

cella est parva camera, semperque toti vel saltem ampliori aedificio opponitur.

a) in templis (*templum*) est pars sacratio et nobilior, in qua signa deorum stabant.

b) cella saepe est locus secretus in aedibus, in quo aliquid ad usum familiae reconditur.

c) in cella vinaria vinum servatur, in cella olearia oleum. sunt etiam cellae farinariae, pomariae, lignariae, caseariae etc.



cento –onis, m.

a) cento est vestis ex variis pannis veteribus ac diversi coloris consuta, qua pauperum lecti sternuntur, ipsique pauperes ac rustici amictiuntur.

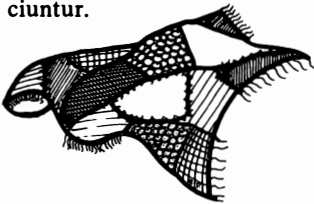

b) centones etiam dorso equorum mulorumque imponebantur, ne dorsum bestiae sellā tereretur.

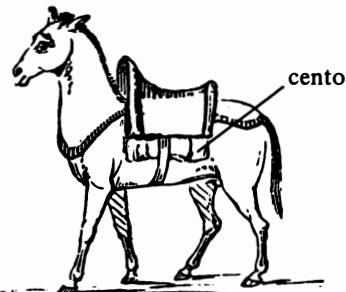

c) translate dicitur genus carminis ex variis alieni operis hinc inde decerptis versibus, et ad alia significanda traductis consarcinatum, qualis est Cento Nuptialis ab Ausonio ex Vergilianis versibus compositus.

centurio –onis, m.

centurio est, qui centuriae praeest. legio enim in decem cohortes divisa erat: hae in ordines ternos, quorum praefecti centuriones dicti sunt.



cervical –alis, n.

est pulvinar quod vel ad mensam vel in cubiculo vel in *lectica* decumbentes cervici et capiti supponimus.

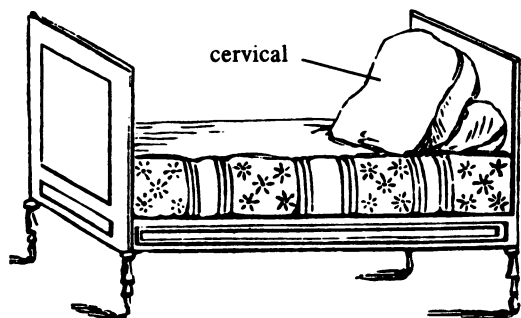

lectus

Charon –ontis / –onis, m.

Charon est portitor inferorum, Erebi filius, quem animas mortuorum per tria Inferorum flumina, Acherontem, Stygem et Cocytum ad ripam adversam cymbā transvehere fabulantur.



chimaera –ae, f.

est monstrum in Lyciā triplex, vertice nempe leonis, media parte caprae ignem vomentis, extrema in draconem desinens; a Typhone genitum ex Echidna. ad monstrum interficiendum missus est Bellerophontes, qui Pegaso, equo alato insidens, illud interemit. chimaera saepe dicitur pro re, quae non exstat vel exstare non potest.



chimaera in vase Corinthio picta

cingulum –i, n.

cingulum est idem quod cinctus aut zona, a verbo cingo (cinxī, cinctum); cingulo succincta est tunica, ut expeditius se movere possit vir (homo *alticinctus*).



cingulum vel cestus



alticinctus



circinus –i, m.

est instrumentum, quo circuli designantur. circini inventorem fuisse Daedalum narrat his verbis Ovidius, *Met.* 8, 247 ss:

„primus et ex uno duo ferrea brachia nodo vinxit, ut aequali spatio distantibus illis, altera pars staret, pars altera duceret orbem.“
(orbis)

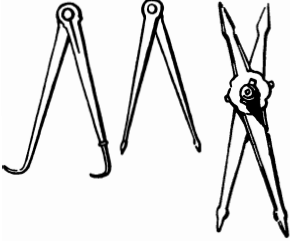

circulator –oris, m.

a) circulator dicitur, qui merces de domo in domum vendit, et qui in omnibus auctionibus praesto est, ut merces, quae ibi forte viliores

pretio vēnirent, coēmeret, deinde cum lucro venditurus.

b) item circulator est homo circumforaneus, qui congregatā multitudinem in foro et per vicos varia medicamenta proponit, et praestigiis, saltationibus, cantu aliisque huiusmodi ludicris plebem detinet et oblectat, lucris causa.
(cf. imaginem.)



circus –i, m.

a) circus est omnis in gyrum (*gyrus*) ambitus; deminutivus: circulus.
b) circus apud astronomos est orbis caelestibus signis circumscriptus.
c) generatim circus erat planities aperta; fere semper orbicularis, at figurā ellipticā, quae publicis praecipue ludis edendis, populorum conciliis habendis etc. inserviebat. Romae plures circi erant. Circus Maximus locus erat muris saeptus, in quo equi pugilesque exercebantur, sic dictus, quia orbicularis erat, longior

tamen quam latior, i. e. figurā ellipticā. Circus Maximus etiam extra ludorum tempora magnā semper populi frequentia celebrabatur, cum eo convenire solerent ludicarum artium professores, circitores (= *circulatores*), physiognomi, somniorum coniectores, multique alii.

Iuvenalis, 10, 81:

(populus) „... nunc se continet atque duas tantum res anxius optat, panem et circenses ...“



imago circi
Barcinone reperta

cirrus –i, m.

cirrus proprie est capillorum nodus in summo vertice (*vertex*) capitis, aut capillus naturā crispus seu contortus.

cirri etiam dicuntur fimbriae tenues in quibusdam vestibus, in extremitatibus earum dependentes.

** propter similitudinem hodie etiam configuratio nubium „cirri“ nominatur.



gladiator cirro
praeditus

classarius –i, m.

classarii sunt milites, qui e navibus (*navis*) pugnabant. etiam nautae et remiges inter classarios numerantur. *classis*, –is, f. est summa navium longarum.

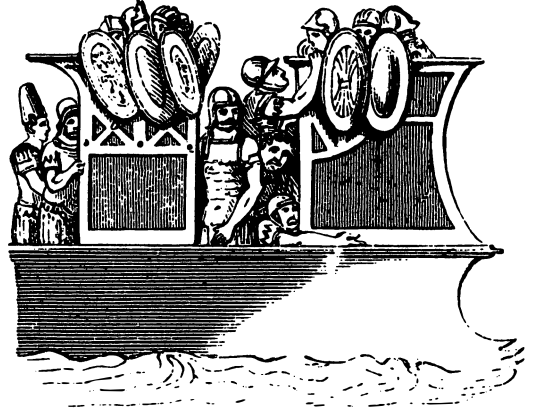

cisterna –ae, f.

cisterna est receptaculum subterraneum aquae pluviae ex stillicidiis (*stillicidium*) collectae ad hominum usum, idque in tectis fiebat; contra „lacus“ ad pecorum usum fiebat sub divo.

Varro, R. R. 1, 11, 2:

„si omnino aqua non est viva, cisternae faciundae sub tectis et lacus sub divo: ex altero loco ut homines, ex altero ut pecus uti possint.“

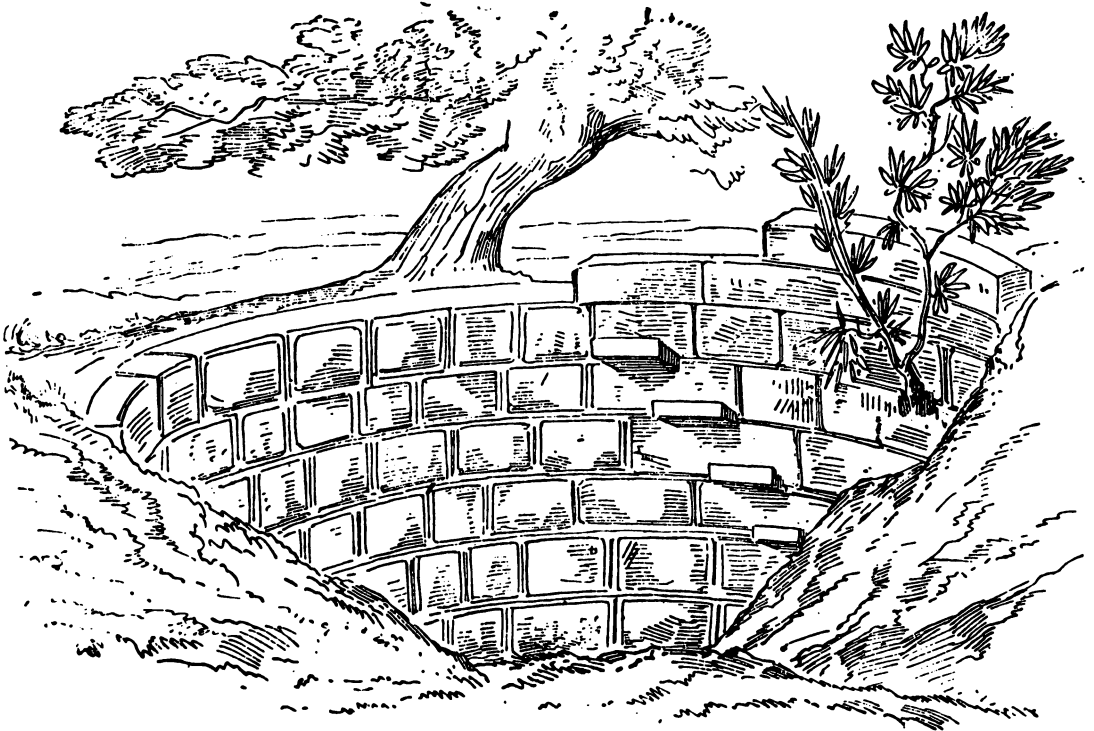

claustrum –i, n.

est quiddam claudendo inseruit, vectis, sera, repagulum, quo ianua aut quidpiam aliud clauditur.

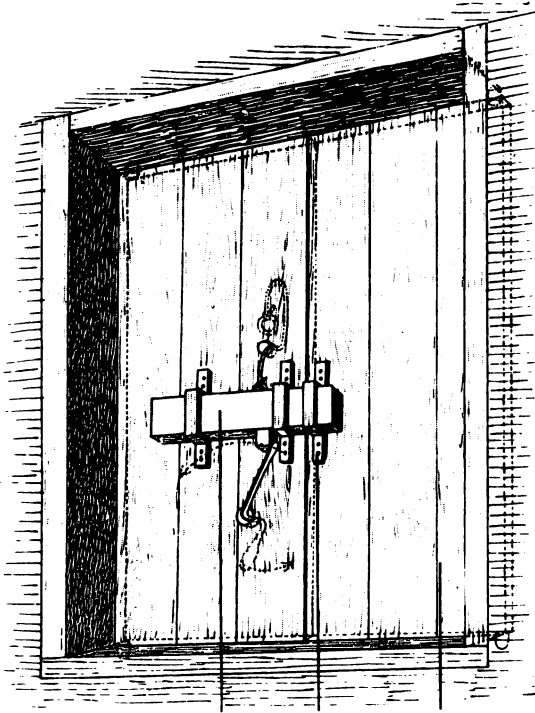

repagulum sera ianua

clava –ae, f.

clava est ramus ex arbore recisus cum nodis, cui maximum pondus inest in parte inferiore. clava numeratur inter antiquissima et rudiora arma.

Lucretius, 5, 966 s.:



claviger

„consectabantur silvestria saecla ferarum missilibus saxis et magno pondere clavae.“
clava Herculi tribuitur, eoque telo plurima domuisse dicitur monstra: Hercules claviger.



clava

clavis –is, –ium, f.

est instrumentum ferreum, quo ostia (ostium), arcae (arca) et id genus multa clauduntur et aperiuntur.

Tibullus, 1, 6, 34:

... „tua si bona nescis
servare, ah frustra clavis inest foribus.“



monumentum
funebre (funus)
Atticum in
opere caelato
sacerdotem
cum
clave templi
repraesentat

clavus –i, m.

clavus est quiddam obtunditur vel percutitur, seu quiddam percutiendo infigitur.

a) id quo aliquid figitur et alteri rei iungitur.



b) fustis, manubrium, quo gubernaculum navis torquetur.

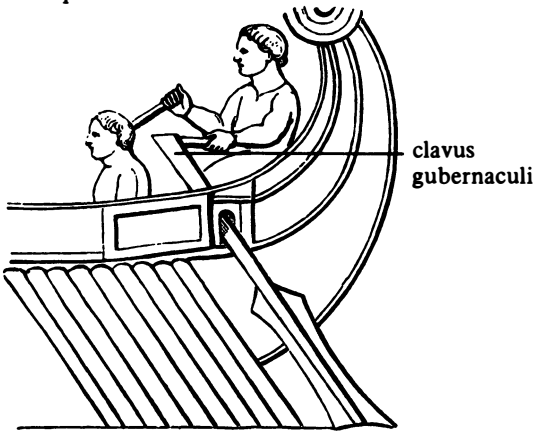

c) clavi in tunicis Romanorum erant segmenta, fere e purpura, ipsi tunicae assuta, ornatūs gratiā. latum clavum adhibebant senatores, angustum equites.

formulae: ad a) adigere clavum in arborem, figere aliquid clavis duplicibus, avellere clavum adactum. mos fuit Romae dextro lateri aedis Iovis Capitolini, ex qua parte fuit Minervae templum, clavum quotannis idibus Septembribus figere, ideo singuli clavi erant indices numeri annorum.

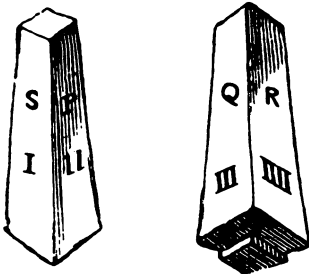

clavus annalis

clipeus —i, m.

clipeus est scutum rotundum, quod milites (*miles Romanus*) sinistra manu gerebant tegendo ab ictibus corpori.

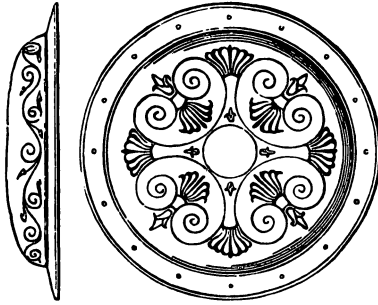

b) latiore sensu dicitur etiam clipeus discus ex aere, aut alia quapiam materia, in qua sculpebantur aut pingebantur deorum ac virorum magnorum imagines usque ad pectus representatae. clipeata imago est imago in clipeo depicta vel sculpta. (*Triton*)

clitellae —arum, f. pl.

sunt *ephippia*, quae imponuntur dorsuariis iumentis, ad onera commodius gestanda.

formulae: clitellis apportare aliquid; clitellas asino imponere. proverbium: „bovi clitellas imponere“, i. e. onus alienum imponere alicui: Quintilianus, 5, 11, 21:

„non nostrum, inquit, onus bos clitellas (videns)“; non est officium meum clitellas portare.

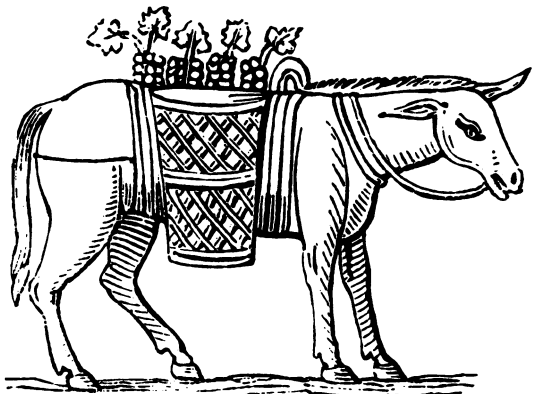

asinus clitellis onustus

cloaca –ae, f.

est *cuniculus*, aquae ductus subterraneus, lateribus vel lapidibus structus, ad deducendas aquam imbrium sordesque urbis. imago exitum Cloacae Maximae, quae etiam hodie exstat, in ripa Tiberis fluminis monstrat.

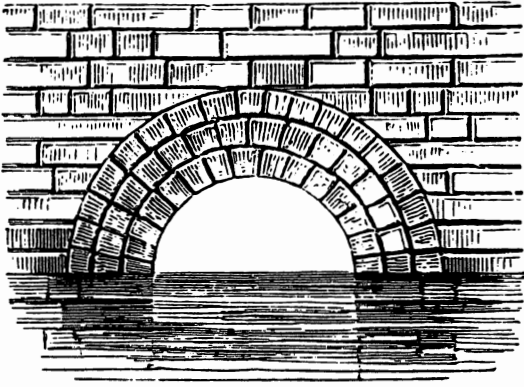

Cloaca Maxima in ripa Tiberis sita

cochlea –ae, f.

cochlea est limax, animal notum, testā inclusum tortili et turbinatā:



cochlea etiam nominatur porta versatilis, qua in ludis circensibus utebantur ad evitandas bestias feras, ut in hoc nummo describitur.



cochlea est etiam machina haustoria ad aquam hauriendam et tollendam. est autem machina, cuius in medio rota est, quae dum a calcantibus (*calco*) versatur, machina intus cochleae instar detornata aquas exsorbet ex aquario saepto et retrorsus emittit.

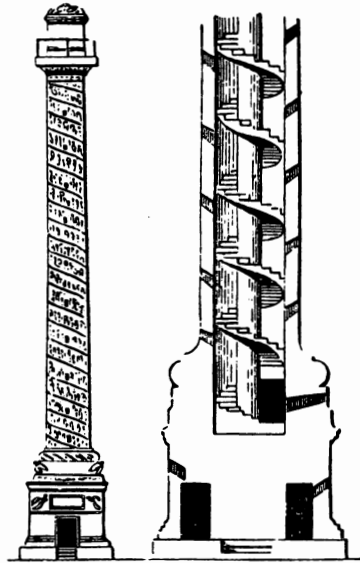

scala cochleata in interiore columna Traiana constructa

cochlear –aris, n.

a) est ligula ex altera parte acuta, ex altera latior et cavata: illā extrahuntur ex sua *testa* cochleae (*cochlea*), hāc ova (*ovum*), alii eiusmodi liquidiores cibi.

b) est etiam *mensura* liquidorum, quarta pars cyathi (*cyathus*).

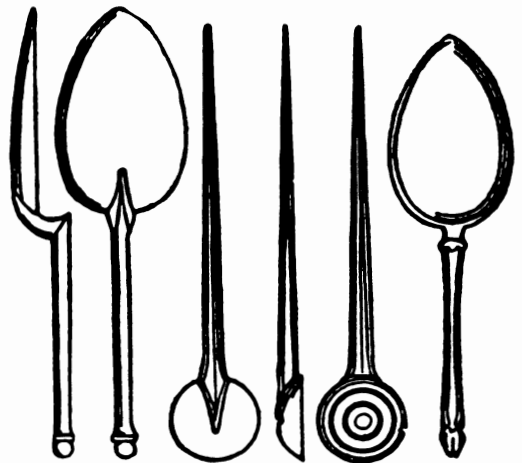

cochlearia Romana

codicillus –i, m.

a) est parvus **caudex** vel arboris truncus.

b) codicilli (vel **pugillares**) sunt parvae tabellae scriptoriae, cerā illitae, in quibus stilo perscribitur. his usi sunt veteres ante chartae inventionem, cum per litteras aliquid alicui significandum erat. **formula**: exarare codicillos.

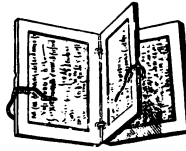

cognatio –onis, f.

cognatio est communis origo, coniunctio naturae et sanguinis; **gradūs cognationis** sunt:

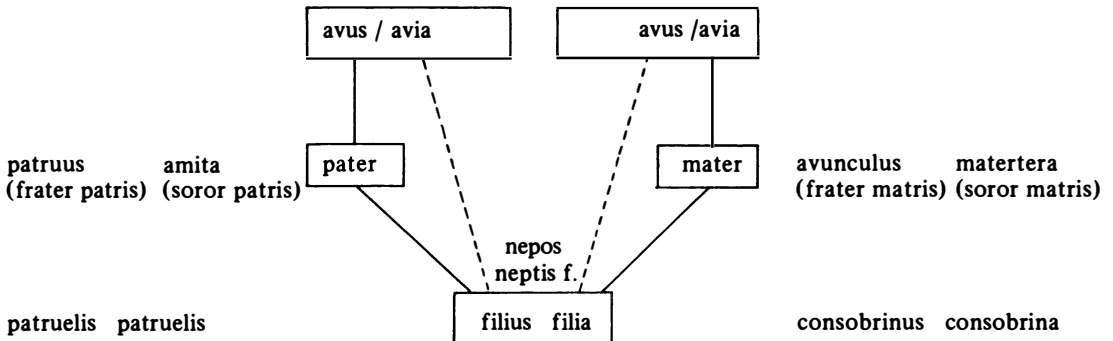

cohors –tis, f.

a) cohors est locus in villa, maceris aut saepe circumdatus, in quo altilis aves custodiuntur et alia ad usum villae servantur.

b) cohors est etiam hominum multitudo, quae

personam aliquam circumdat, hominum manus, comitatus. **cohors praetoria** circa imperatorem erat custodiae causā. et sub imperatoribus aulicorum quoque turba cohors dicta est (it. corte, fr. cour).

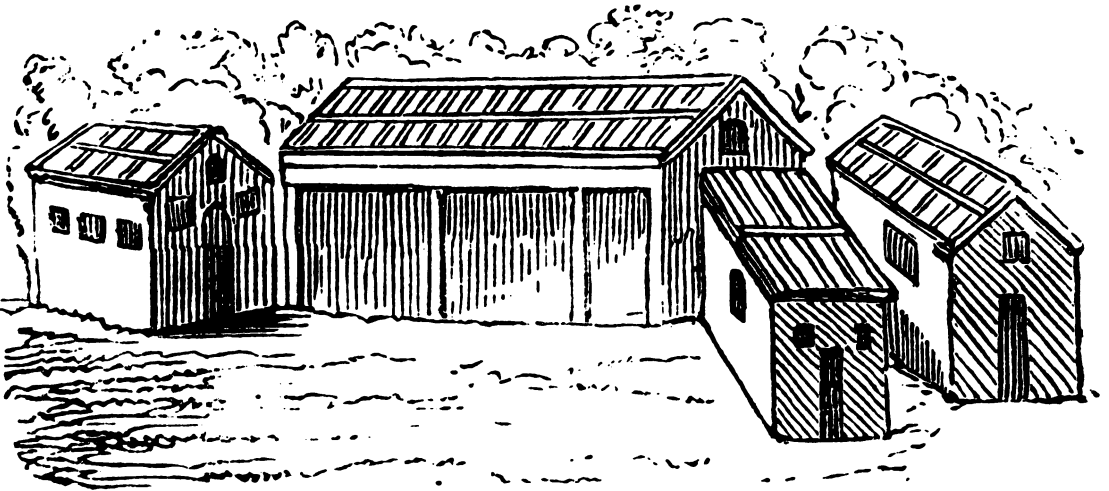

colonia –ae, f.

colonia est pars civitatis aut sociorum deducta in aliquem locum, colendi et inhabitandi gratiā; itemque ipse locus.

coloniae civiles constabant ex civibus pauperibus, qui in aliquem locum agri colendi causā deducebantur; coloniae militares constabant ex militibus veteranis, qui in aliquem locum tamquam in laboris requiem deducebantur, simul ut adversus hostium incursiones praesidio essent.

coloni sunt cives unius civitatis in aliam deducti et eius iure utentes, a qua sunt propagati.

columbarium –i, n.

a) est locus, in quo habitant columbae.

b) a similitudine sic appellatur etiam cubile tigni et trabis in aedium parietibus.

c) item foramen rotundum in machina haustoria, per quod aqua in tympano (*tympanum*) concepta egreditur.

d) item locus in sepulcris, in quo olla cinerum reponebatur. (vide illustrationem.)

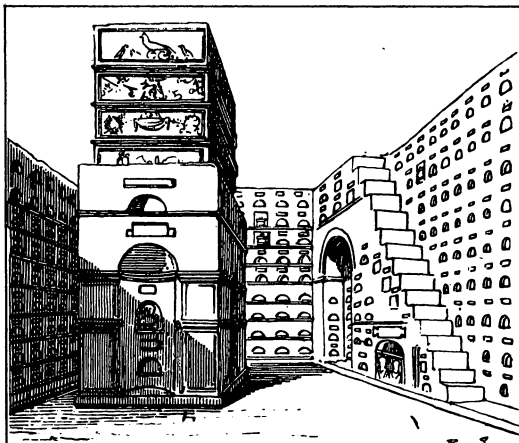

commutatio –onis, f.

commutare est aliud pro alio substituere.

Cicero, Off. 1, 13, 39:

„Regulus de captivis commutandis Romam

missus (est).“

commutare vinum pro oleo, vel oleum pro vino; genus est commercii sine pecunia.



De commutationibus rerum, & mercium sine nummis.

imago sumpta ex Olai Magni opere

compedes –um, f. pl.

compedes sunt vincula, quibus servorum, captorum aliorumve pedes vinciuntur, e ligno aut e ferro; compedibus opponuntur „manicae“. „compeditus“ est servus compedibus victus.



compeditus

compendium –i, n.

a) est quidquid lucratur rem nostram servando. **formulae:** compendium facere, compendi facere. **Plautus**, *Pers.* 471:

„ego hodie compendi feci binos panes.“

b) latiore sensu generatim est lucrum ex deminutione operae, actionis, temporis ... et interdum est abbreviatio.

compendium viae, quod saepius compendium absolute dicitur, est **via brevior**.

formulae: compendio ducere aliquem = breviori via ducere aliquem; viā compendiarī ire.

compitum –i, n.

est locus, ubi plures viae competunt, hoc est confluunt, sive *bivium* illud sit, sive *trivium*, sive *quadrivium*.

adi. **compitalis**, a quo **compitalia** –ium, n. pl. sunt dies attributi Laribus Compitalibus. celebrabantur hiemis tempore non multo post Saturnalia. non tamen habebant diem certum, sed concipiebantur quotannis a praetore.



arae in compito erectae

concordia –ae, f.

est unanimitas et consensus, eique opponitur discordia, ut apud **Sallustium**, *Iug.* 10: „concordiā res parvae crescunt, discordiā maximae dilabuntur.“

congiarium –i, n.

a) ad congium (*congius*) pertinens.

b) vas congiarium: quod congium capit.

c) congiarium est donum, quod antiquitus in Romana re publica distribuebatur in populum, et erant tot congii vini aut olei aut salis, etc.

Livius, 25, 2:

„Ludi Romani magnifice facti et congii olei in vicis singulos dati.“



donator congiarii in suggesto sedens tesseras congiarii distribuit

congius –i, m.

est mensura liquidorum continens sextarios sex, heminas autem duodecim. erat autem pars octava *amphorae*, et vino aut aqua plenus pendebat libras decem. in hac imagine congium praebente P. X. significat „pondo decem“, h. e. libras decem continens.

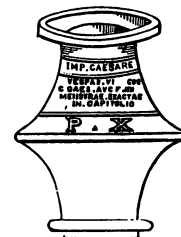

copula –ae, f.

- a) est vinculum, nexus, quo plura simul ligantur et connectuntur. specialiter dictum est de vinculo, quo alligantur canes venatici.
- b) translate: amicus est copula virorum dissimilium; e. gr. Atticus Ciceronem et Hortensium tamquam copula vinculo amicitiae constrictos habebat.
- c) speciatim dicitur de verborum nexu et compositione.
- d) **in logica: copula est nexus verbalis inter subiectum et praedicatum; plerumque copula verbum auxiliare est.

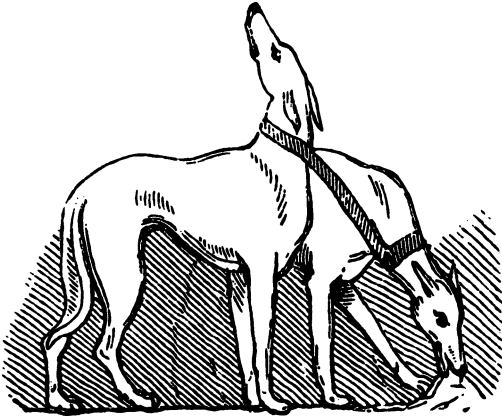

canes venatici copula iuncti

corbis –is, f./m.

corbis est vas e vimine, ad usus rusticos, praesertim colligendorum fructuum. corbis etiam mensura est. per corbem mensuram vini facere est metiri modum vini ex modo uvae, cuius mensura per corbem definiri solet.

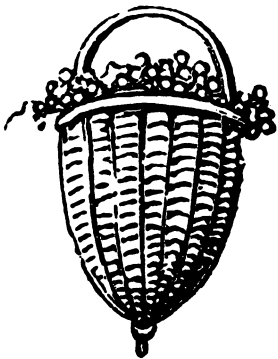

corbita –ae, f.

est navis oneraria duorum mālorum (mālus, –i), quorum unus corbem (*corbis*) gestat, e quā cursus navis observabatur. a vocabulo „corbita“ derivatur fr. gall. „corvette“.

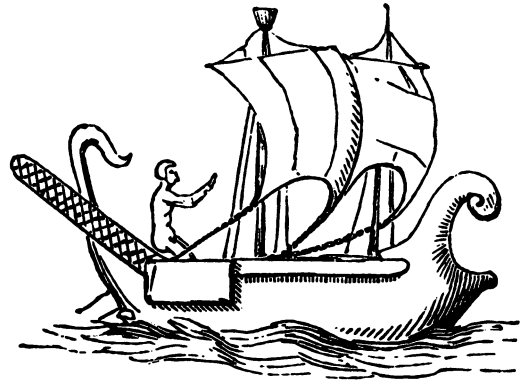

cornicen –cinis, m.

est is, qui cornū (*instrumenta musica*) signa canit; confer: *tibicen*, qui tibiā canit, *fidicen*, qui fidibus canit. f.: *tibicina*, *fidicina*.



cornicen in arcu Constantini fictus

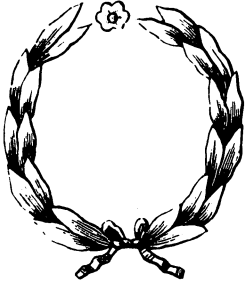

corona
triumphalis

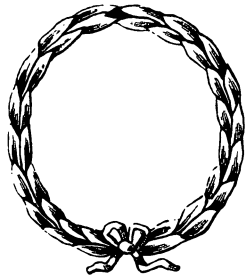

corona
ovalis



corona
obsidionalis

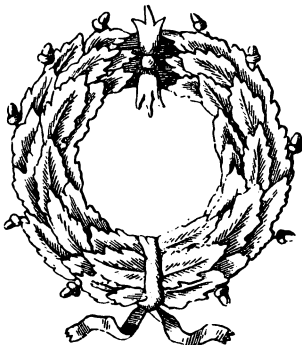

corona
civica

corona est ornamentum circulare capitis, sertum, strophium. coronae, quae virtutis ergo dabantur, diversorum generum fuerunt, scilicet corona vallaris, c. castrensis, c. civica, c. muralis, c. navalis, c. obsidionalis, c. triumphalis, de quibus Gellius, 5, 6:

„triumphales coronae sunt aureae, quae imperatoribus ob honorem triumphii mittuntur ... obsidionalis est, quam ii, qui liberati obsidione sunt, dant ei duci, qui liberavit ... civica corona appellatur, quam civis civi, a quo in proelio servatus est, testem vitae salutisque perceptae dat ... muralis est corona, qua donatur ab imperatore, qui primus murum subiit inque oppidum hostium per vim ascendit; idcirco quasi muri pinnis decorata est. castrensis est corona, qua donat imperator eum, qui primus hostium castra pugnans introivit; ea corona insigne valli habet. navalis est, qua donari solet, maritimo proelio qui primus in hostium navem vi armatus transsiluit; ea quasi navium rostris insignita est. et muralis autem et castrensis et navalis fieri ex auro solent. ovalis corona murtea est: ea utebantur imperatores, qui ovantes urbem introibant. ovandi ac non triumphandi causa est, cum aut bella non rite indicta neque cum iusto hoste gesta sunt, aut hostium nomen humile et non idoneum est ut servorum piratarumque, aut deditione repente facta ‚impulverea‘, ut dici solet, ‚incruentaque victoria obvenit‘.“

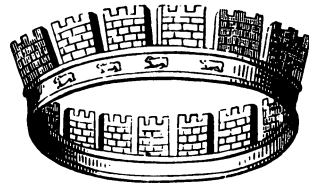

corona
muralis

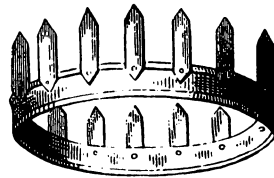

corona
vallaris

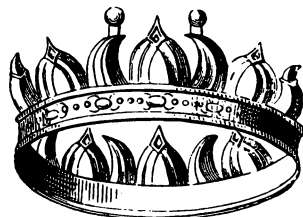

corona
navalis

corpus humanum

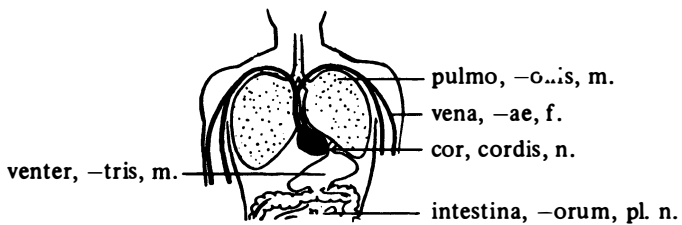
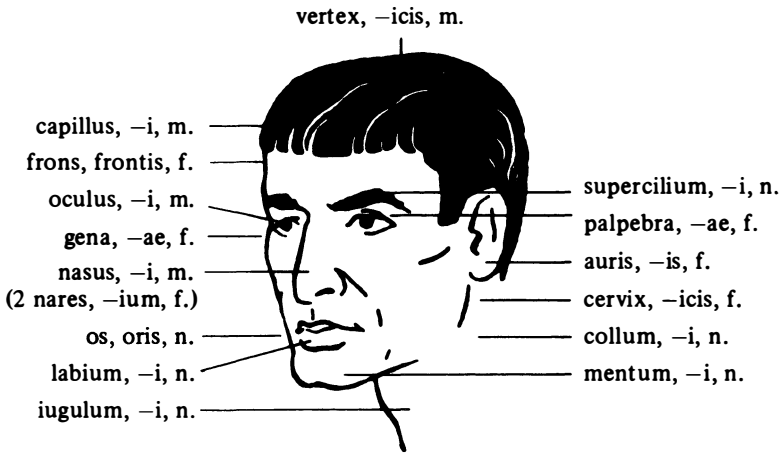
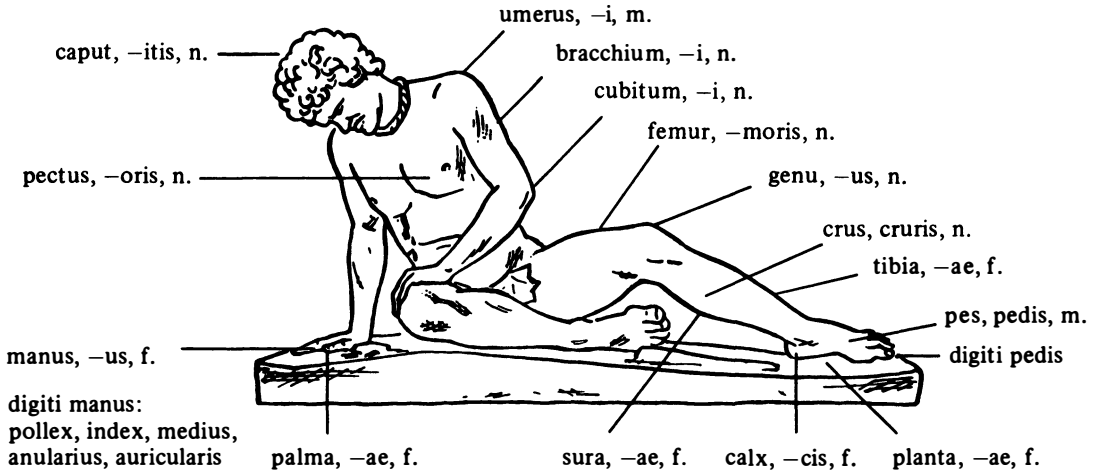

corrigia –ae, f.

corrigia est lorum, quo calcei et *caligae* ligantur, saepe e corio canino facta.



calcei corrigiis ligati

cortina –ae, f.

a) cortina est vas rotundum et concavum ad varios usus.

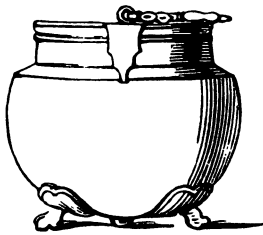

cortina

b) latiore sensu cortina dicitur *tripus* ipse Apollinis, ex quo responsa oraculorum dabantur, quod tripodis impositum erat vas cortinae similitudinem habens.

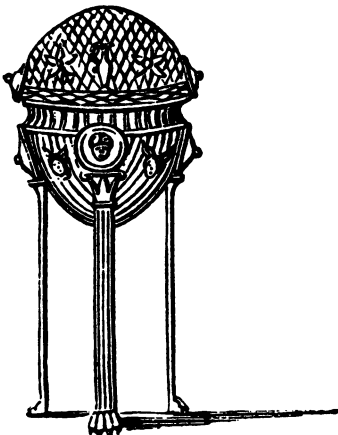

cortina in tripodis

crates –is, f.

a) crates est instrumentum ex subtilibus lignis vel viminibus aliāve materiā, directis transversisque modico intervallo contextis, ad varios usus.
b) crates ferrea carni torrendae inservit.

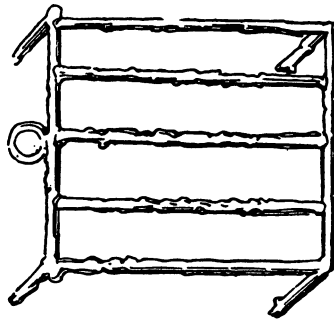

crates ferrea

crepido –inis, f.

est basis alta et erecta, fundamentum, fulcrum. crepido est moles alta et abrupta, quā maris *litus* vel ripa fluminis munitur contra aquarum impetū.

crepidines viarum sunt margines vel gradus ex petra, ipsā viā aliquanto editiores, qui et commodius praetereuntibus iter et meliorem domibus accessum praebent.

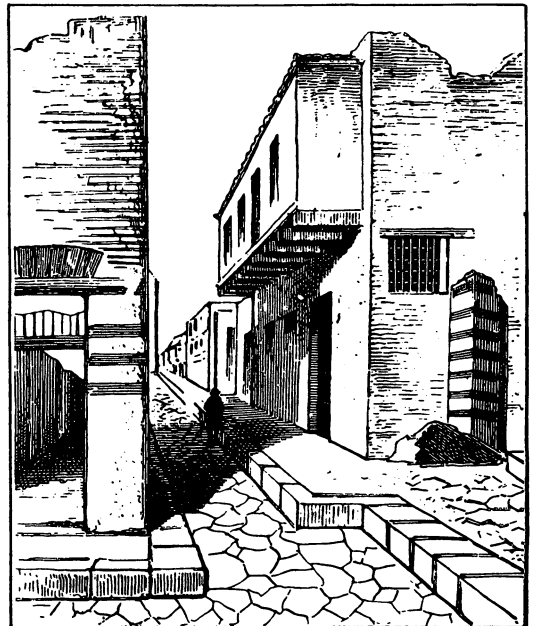

semita Pompeiorum cum crepidinibus

crepitaculum –i, n.

est instrumentum ludorum ex aere aliāve materiā, quod manu concussum crepitat ac sonum reddit.

Martianus Capella, 9, 314:

„infantibus crepitacula vagitūs abrumpunt.“
vox derivatur a voce crepitus, crepitare: pedum crepitus, cardinum crepitus. formula dicendi: crepitus digitorum, vel crepere digitis.

Martialis, 3, 82:

„digiti crepentis signa novit eunuchus.“

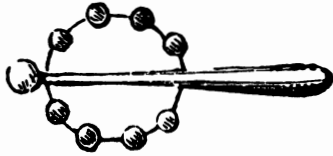

cribrum –i, n.

est instrumentum crebris et minutis foraminibus pertusum, ex pellibus perforatis, vel lino, aut



cribra in opere caelato sepulcri Eurysacis pistoris (*pistor*), Romae

setis, aliave materia contexta, quo frumenta, farina, et alia cernuntur et purgantur.

proverbium: „cribro aquam ferre“ dicitur pro operam perdere, frustra laborare.

verbum derivatum: cribro, –as, –avi, –are = secernere, purgare.

crista –ae, f.

a) crista est apex in vertice gallinaei generis.

Plinius, H. N. 10, 56, 77:

„gallarum generositas spectatur cristā erectā“

b) dicitur etiam de apice galeae (*galea*).

Livius, 9, 40:

„cristatae galeae, quae speciem magnitudini corporum adderent.“



cristae in galeis

crypta –ae, f.

a Graeco krypto = „abscondo“.

crypta est locus fere subterraneus fornix (*fornix*) tectus cum fenestris (fenestra) in

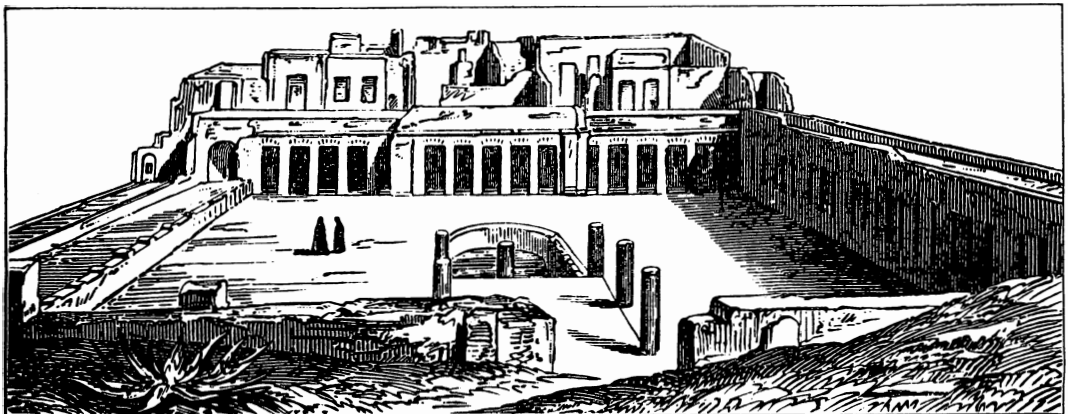

crypta villae Pompeianae

summitate modo. saepe haec vox de granario subterraneo usurpabatur.

Vitruvius 6, 5, 2:

„in aedibus cryptae, horrea, apothecae, ceteraque quae ad fructus servandos magis quam ad elegantiae decorem possunt esse.“

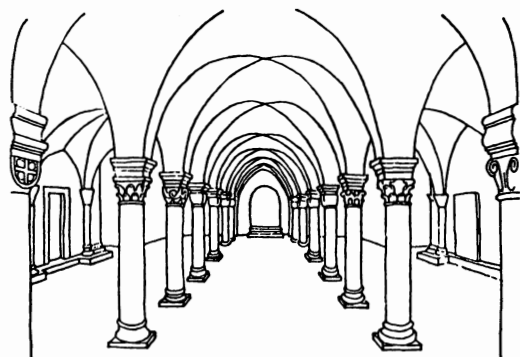
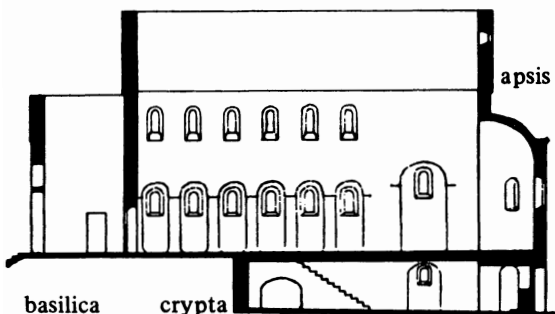

**crypta est pars inferior aedis sacrae, aram, sepulcraque sanctorum complectans.

Ctesibica machina

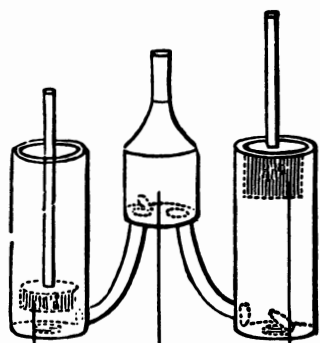

modiolus catinus modiolus

est machina, quae in altitudinem aquam educit. fuit autem Ctesibius vir Alexandrinus, qui sub Ptolemeo Philadelpho floruit et pneumaticam rationem atque hydraulica organa (organum) repperit.

cuculla –ae, f. / cucullus –i, m.

est pars vestis a tergo pendens, qua caput tegitur pluviae vel tempestatis causā.

cucullatus est is, qui vestem cum cuculla fert.

**multi monachi vestem cucullatam gerunt.



agricolae cucullati, qui olivas metunt



puerulus cucullatus

cucullus erat etiam involucrem chartaceum, quo a pharmacopolis aliisque institoribus pulveres ac similia clauduntur.



culina –ae, f. / **coquina** –ae, f.

utensilia culinae domus Pompeianae:



culter –tri, m.

in hac imagine depicta est taberna cultrarii, qui cultros cuiusque generis et formae vendit:

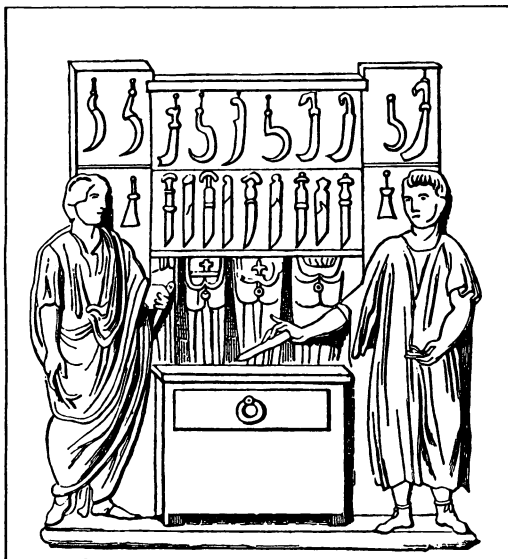

cumulus –i, m.

cumulus est acervus multarum rerum in altitudinem congestarum.

formula dicendi: struere cumulos auri.

**cumulus est configuratio nubium, quae tempestatem aut bonum tempus praenuntiant.

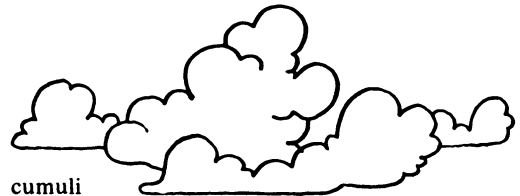

cuneus –i, m.

a) cuneus est instrumentum ferreum aut ligneum, quo finduntur ligna, cuius pars inferior acuta est, superior lata et ampla.



Vergilius, G. 1, 144:

„... cuneis scindebant fissile lignum.“

b) cuneus improprie dicitur quidquid cunei figuram refert.

c) sumitur et pro sedilium ordine et scararum directione in theatris (*theatrum*) et amphitheatris (*amphitheatrum*), quae ita cum praecinctio- nibus disposita erant, ut universam sedilium seriem in partes cuneorum similes dividerent.

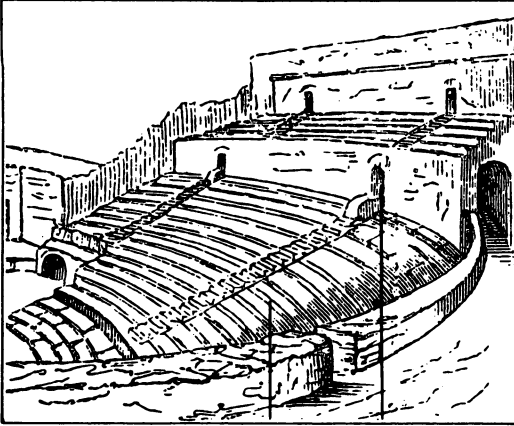

cunei vomitorium

cuniculus –i, m.

a) est animal lepori simile, sub terra effossa latere solitum, ex Hispania oriundum.

b) est meatus subterraneus, praesertim qui fit urbium oppugnandarum causa.

Caesar, B. G. 8, 43:

cuniculis venas fontis interciderere atque avertere. avertere.

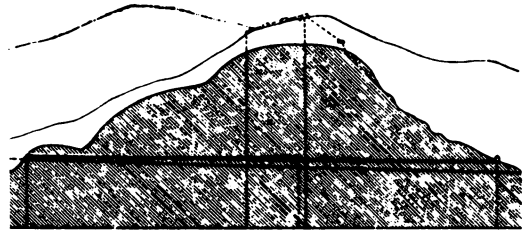
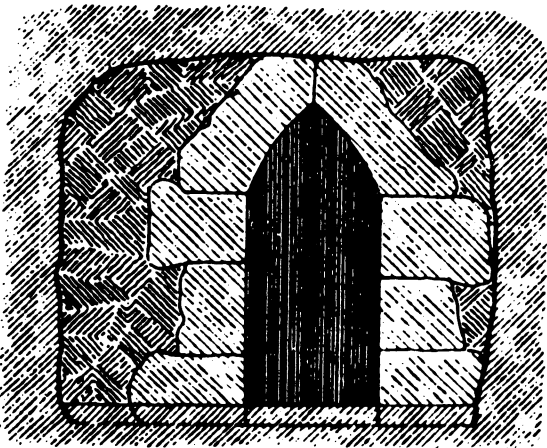

Eupalini architecti cuniculus

Cupido –inis, m.

Cupido est Veneris filius, formosissimus omnium deorum, puer arcu (*arcus*) et sagittis (*sagitta*) armatus.

Plautus, Pers. 26/27:

„... saucius factus sum in Veneris proelio, sagittā Cupido cor meum transfixit ...“

nomen eius deductum a nomine verbali „cupido“ –inis, f., a „cupio, cupivi, cupitum, cupere“. saepe occurrit etiam plurali numero:

Catullus, 3, 1:

„Lugete, o Veneres Cupidinesque“



Venus (Aphrodite), quam quattuor Cupidines (Erotes) comitantur

currus –us, m.

currus est vehiculi genus, hominibus per urbem aut in itinere vehendis aptum, duabus rotis munitum.

speciatim dicitur de curru, quo triumphantes in Urbem vehebantur.

Cicero, Verr. 5, 30, 77:

„at etiam qui triumphant, cum de foro in Capitolium currum flectere incipiunt ...“

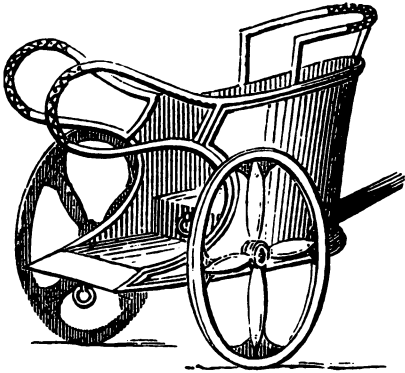

currus

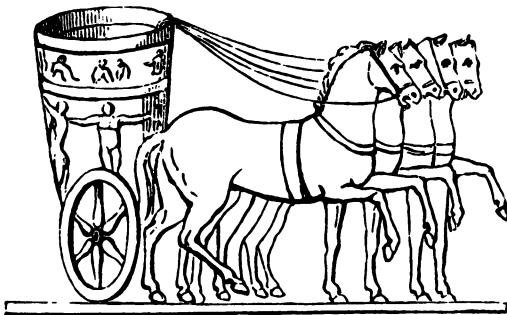

currus triumphalis

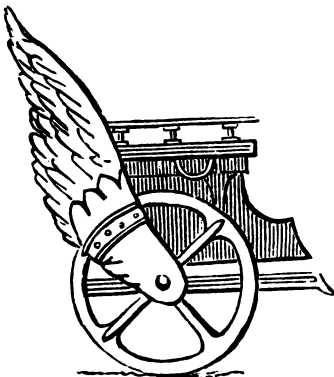

currus volucris vel alatus

curulis, sella curulis

sella curulis fuit unum ex insignibus (*insigne*) primum quidem regum Romanorum, deinde, iis exactis, maiorum magistratum solummodo, nempe consulum, praetorum, censorum et aedilium eorum, qui de patribus creati sunt, ut distinguerentur ab aliis aedilibus sellae ius non habentibus. sella curulis erat curvis pedibus, signis (*signum*) ornata, sublata gradibus, insculptaque et distincta eboze.

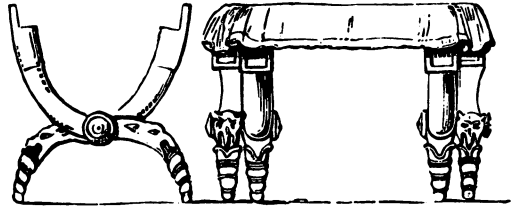

Daedalus et Icarus

Daedalus primus artifex fuit. Cnossi in Creta insula iussu regis Minois labyrinthum (*labyrinthus*) exstruxit. cum a Minoe captivus retineretur, sibi filioque suo Icaro alas cereas perfecit,

quibus ex insula evaderet. Icarus autem, nimis fidens alis cereis soli appropinquavit. alis calore solis liquefactis in mare cecidit et haustus est aquā.

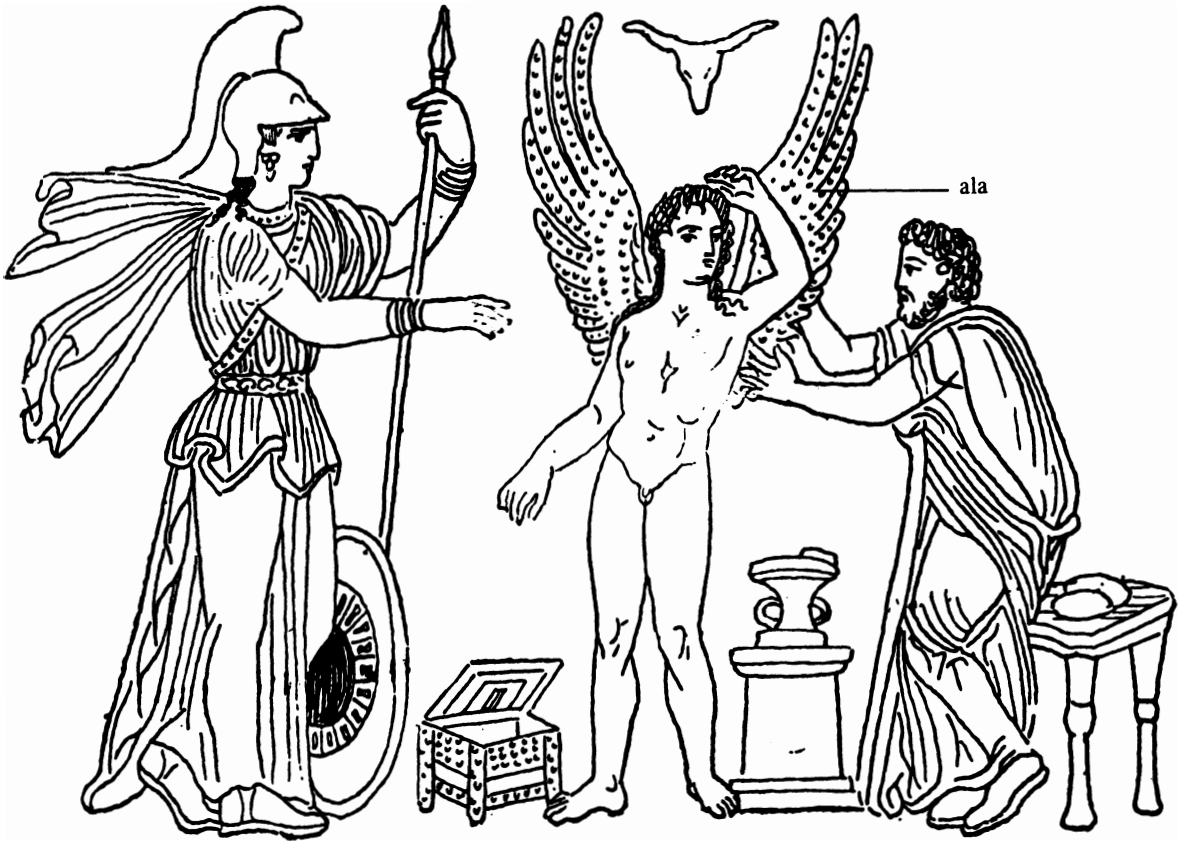

Danaides —um, f. pl.

filiae Danai, regis Argorum. fabulantur quinquaginta eum habuisse filias eiusque fratrem Aegyptum totidem filios, qui ne ille de filiabus per generos ac nepotes potentior factus ius ablatum

sibi vindicaret, ab eo petiit ut filiis suis filias daret uxores, cui Danaus maligne annuit. sed nuptiis vix celebratis sponsae (*sponsus*), a patre instigatae, sponso omnes nuptiali nocte occiderunt, demptā Hypermnestrā, quae Lynceoe peperit; cuius delicti poenam subeunt in inferis, ad dolium pertusum aquā implendum damnatae, e quo tantundem effluat quantum infundatur.



decumanus —i, m.

a) decumanus ager est ager, qui decimam partem fructuum pro vectigali solvit rei publicae.
b) decumanus limes est, qui ab oriente ad occidentem ductus est. prius decumanus dictus est duodecimanus, ab hora duodecima diei, qua sol occidit: spectat enim in occidentem. (*cardo*)

defectio /eclipsis

defectio vel eclipsis lunae fit, cum sol per interpositionem terrae ita lunae opponitur, ut illam illustrare non possit; eclipsis solis, cum luna inter solem et nostrum aspectum interponitur.

Cicero, de div. 2, 6, 17:
 „solis defectiones itemque lunae, praedicuntur in multos annos.“

luna

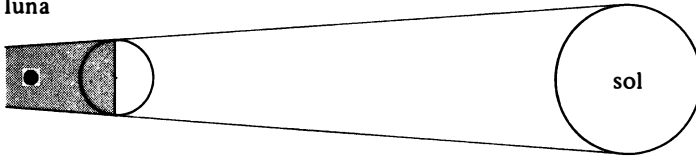

defectio lunae

terra

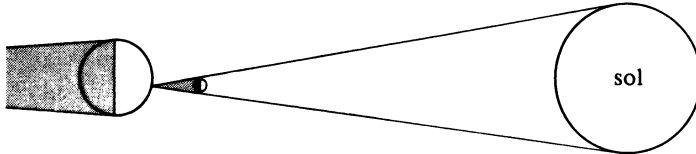

defectio solis

luna

Delphi –orum, m. pl.

sacrum Apollinis

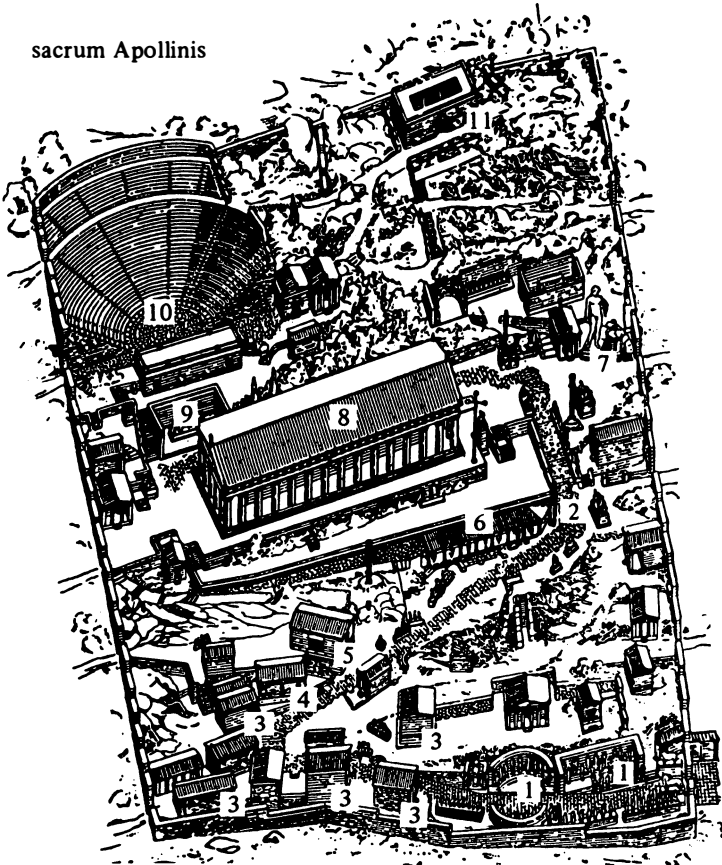

- 1 dona votiva
- 2 via sacra
- 3 thesauri
- 4 Atheniensium thesaurus
- 5 curia
- 6 aula Atheniensium
- 7 statua Apollinis
- 8 templum Apollinis
- 9 Alexandri venatio leonum
- 10 theatrum
- 11 aula Cnidiorum

diadema –atis, n.

est regium *insigne* capitis, candida fascia, vitta, qua regia frons praecingebatur. saepe diadema ex auro et gemmis contextum est.
„diadematus“ est is, qui diademate ornatus est.



Constantinus Constantiusque imperatores, diademate ornati

diatretum (sc. vas diatretum)

in quo tessellato opere aurum, argentumve aut gemmae insertae sunt.
vas diatretum e vitro factum, ornamentis vitreis induitur quemadmodum vas diatretum in imagine expositum.

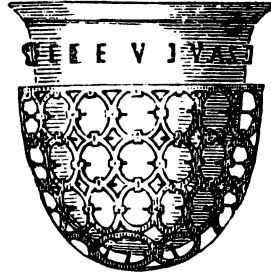

diptychum –i, n.

est id, quod duas valvas habet. tabellae plicatiles, quae panduntur et clauduntur habentque usum litteris praesertim amatoriis, conscribendis.
diptycha consulum, quaestorum, etc. erant ta-

bellae eorum nominibus inscriptae, et imaginibus adornatae, quas ipsi ad amicos mittebant apophoreti vice, et in vulgus spargebant ipso die magistratus initi.



diptychum consulis Rufii Probiani, ex ebore factum (= diptychum eburneum)

divortium –i, n.

idem est quod deverticulum.

a) dicitur de loco, in quo a via militari devertimus: divortium itineris.

b) item ubi aquae in diversas partes defluunt, ut sunt cacumina montium.

Cicero, ad Att. 5, 20:

„mons Amanus, qui Syriam a Cilicia ima aquarum divortio dividit.“

c) speciatim dicitur de discessione coniugum et dissolutione matrimonii.

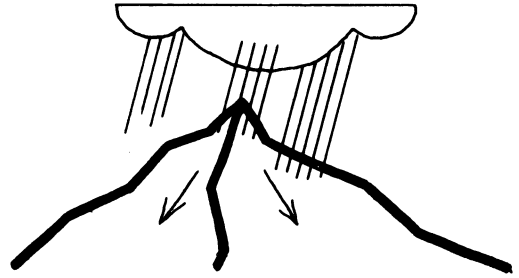

dolium –i, n.

est vas ex maioribus, quibus vinum conditur, et in cellis servatur, capax, rotundum et ventriosum.

primo dolia fuerunt fictilia, deinde etiam lignea et multo capaciora, asseribus vimine constrictis, ut hodieque apud nos. (*cella vinaria*)

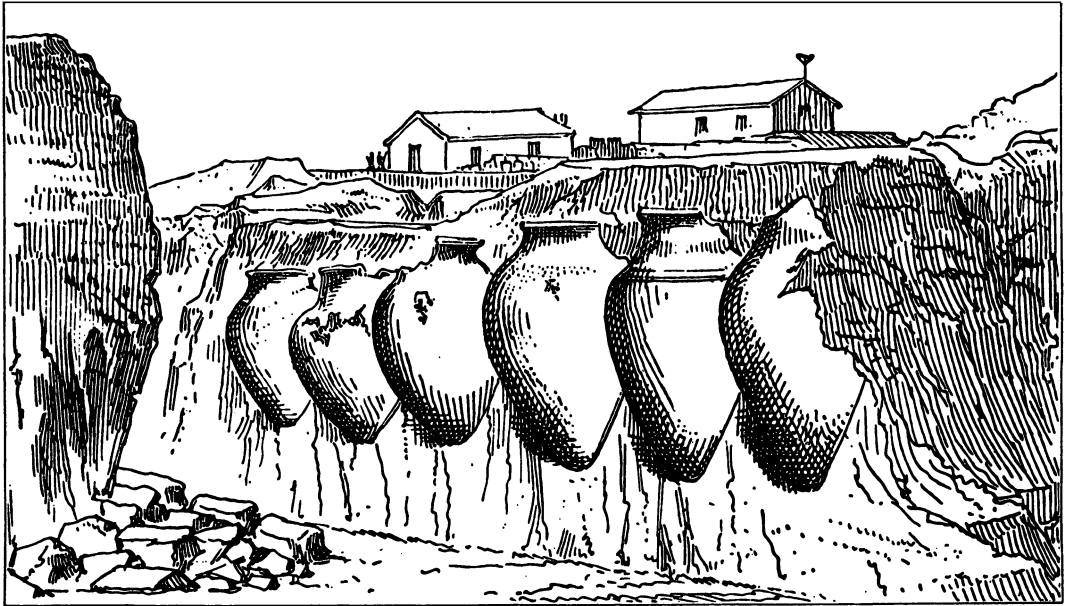

dolia fictilia prope Troiam inventa



Diogenes philosophus cynicus Athenis in dolio parce vixit. cum Alexander Magnus eum interrogaret, si quid vellet, respondit: „paululum a sole!“

domus Romana cum atrio et peristylis

peristylis (aut peristylum) est aula magna multis columnis circumdata, interior pars sub divo est.

tablinum: in tablino tabulae rationum reponantur.

peristylis

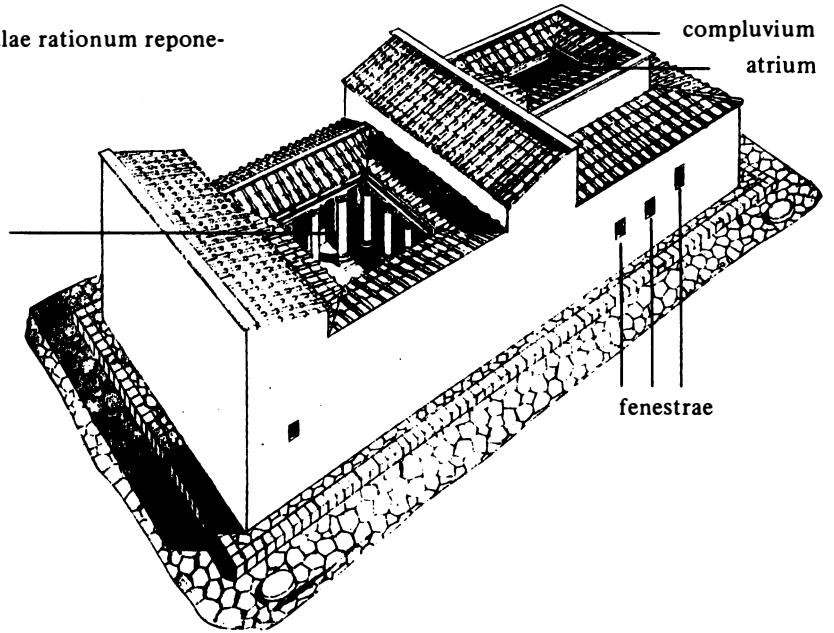

orthographia

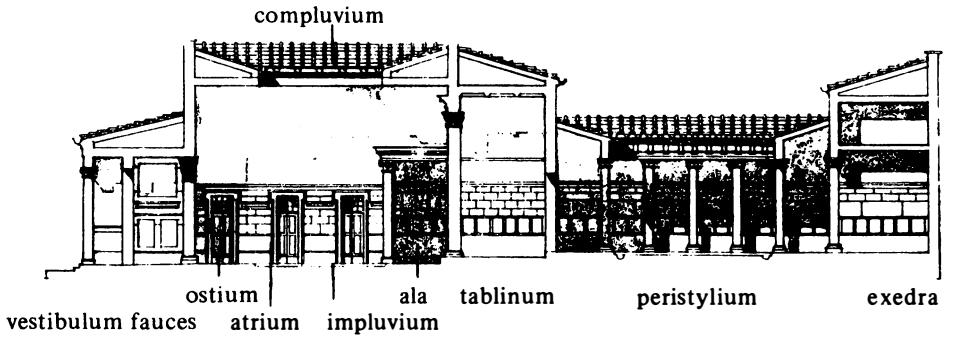

ichnographia

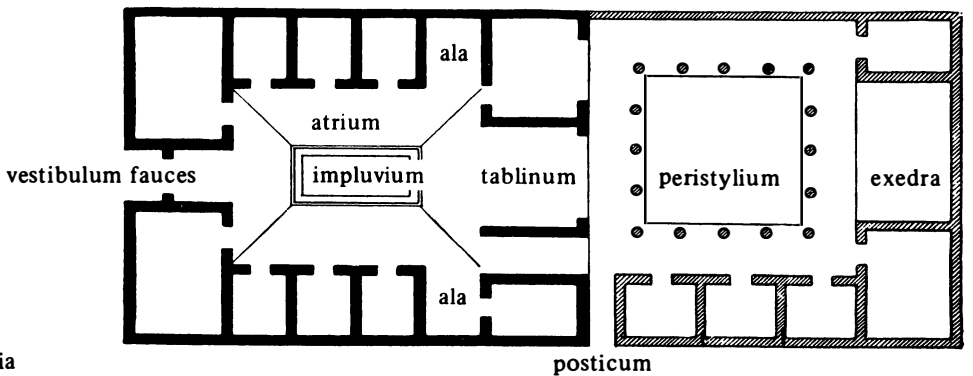

domus Romana cum tabernis

pluvia per compluvium in impluvium cadit.
 impluvium in medio atrio situm est. cubacula
 aliaque conclavia circum atrium sunt.
 duo conclavia in viam aperiuntur; locata sunt
 tabernarii, qui hic officinam suam habent.

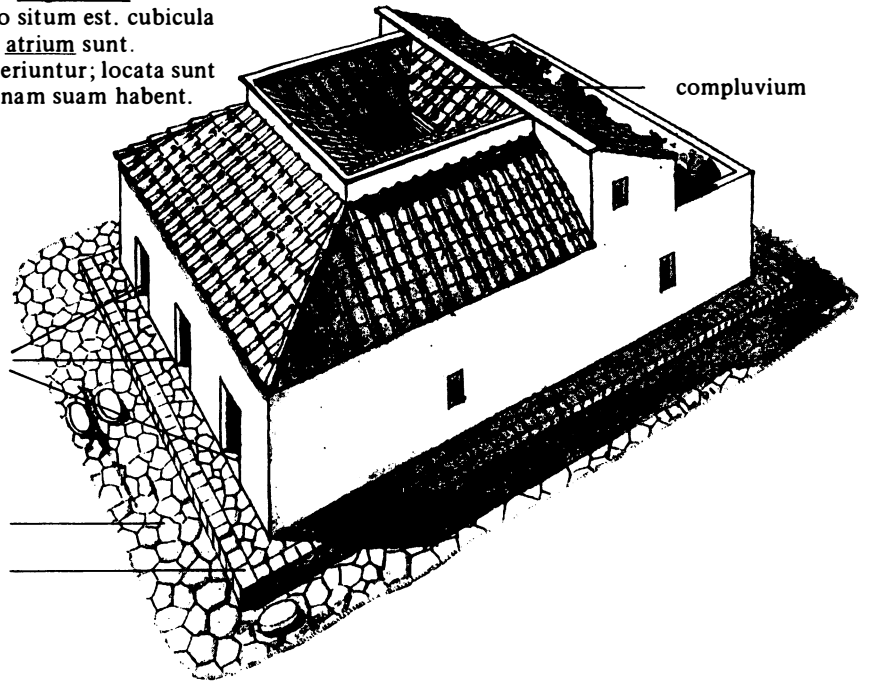

tabernae

via

crepido



orthographia

fauces atrium ala tablinum hortus

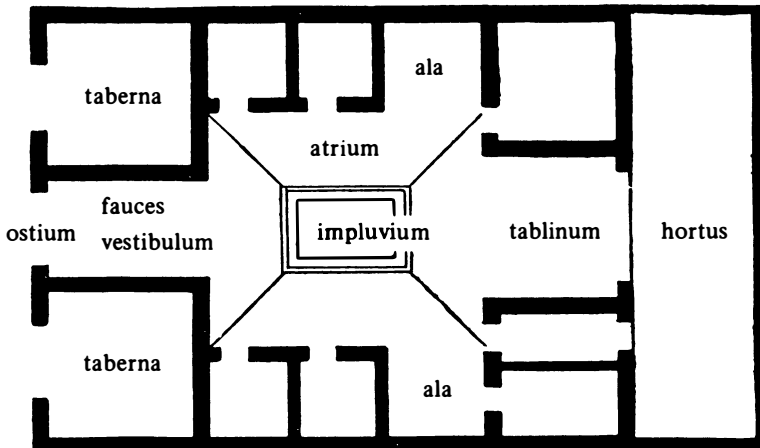

ichnographia

elementa –orum, n. pl.

a) sunt principia omnium rerum, e quibus reliqua omnia componuntur et in quae resolvuntur. temporibus antiquis quattuor elementa nominabantur.

Seneca, Ira 2, 19:

„cum elementa sint quattuor, ignis, aqua, aei et terra, potestates pares his sunt, frigida, fervida, arida atque humida.“

b) elementa dicuntur notae litterarum, quia sunt prima principia orationis; nam ex litteris syllabae, ex syllabis dictiones (vocabula), ex dictionibus oratio conficitur.

c) item principia artium et scientiarum ut arithmeticae, geometriae, musicae etc. elementa vocantur.

***elementa hodie numero 104 sunt, e quorum numero aliquot nomina Latina et symbola chimica haec sunt: aurum (Au), ferrum (Fe), argentum (Ag), cuprum (Cu), sulphur (S), oxygenum (O), hydrogenum (H), aluminium (Al), calcium (Ca), carbo (C), chlorum (Cl), magnesium (Mg), argentum vivum = hydrargyrum (Hg), phosphorus (P), radium (Ra), uranium (U) etc.

adi. elementarius: ad elementa pertinens.

ephippium –i, n.

est stragulum equi, sedendi causa.

a quarto p. Ch. n. saeculo, ephippio etiam sella equestris imponebatur.

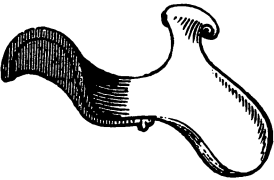

sella
equestris

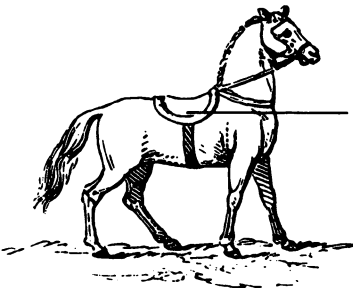

ephippium

epitonium –i, n.

significat instrumentum, quo, prout hoc aut illo modo versatur, liquor emittitur aut occlusus retinetur. in balneis (balneum) erat verticillum seu verticillum pertusum, cuius conversionibus aqua e fistulis emittebatur, aut inibi occludebatur.

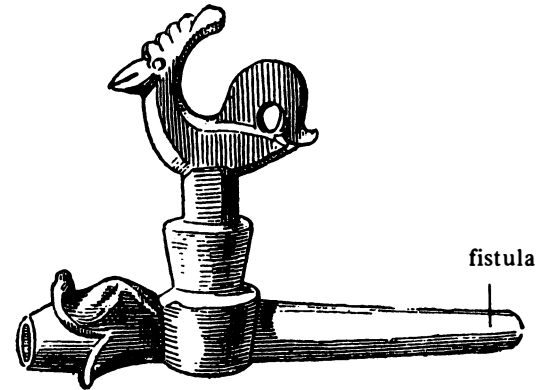
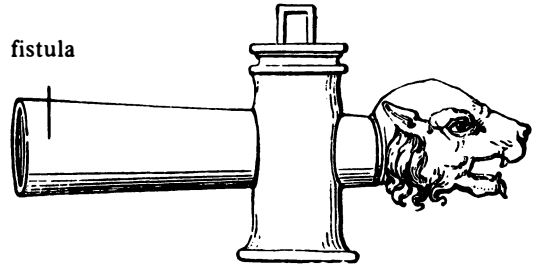

epitonium Romanum Vindonissae repertum

hodie etiam ***epitonium electricum usurpatur, quo fluidum electricum emittitur aut occluditur:

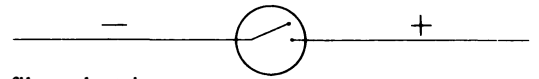

filum electricum

etesiae –arum, f. pl.

sunt venti quidam statis temporibus quotannis flantes, plerumque ab occidente.

Tacitus, Hist. 2, 98:

„mare quoque etesiarum flatu in orientem navigantibus secundum, inde adversum erat.“

Europa –ae, f.

fuit filia Agenoris, regis Libyae aut Phoeniciae, quam fabulantur a Iove in taurum converso raptam et abductam esse in Cretam et Europam, cui parti mundi nomen dedit.

Paulus Festus, p. 78 M:

„Europam tertiam orbis partem ab Europa, Agenoris filia, certum est appellari. sed alii de

amore Iovis in taurum versi narrant; alii eam a praedonibus raptam et navem, quae Iovis tutelam effigiem tauri habuerit, in eam regionem esse delatam; quidam vero ob pulchritudinem regionis per simulationem raptae filiae occupatam eam terram ab Agenore et Phoenicibus ferunt.“



examen –inis, n.

a) examen dicitur de apibus, cum ex alveario (*alvearium*) evolant, expulsae a maioribus.

b) examen est lingula librae seu *libra* ipsa aut actio librandi vel aequilibrium.

Vergilius, *Aen.* 12, 725:

„Iuppiter ipse duas aequato examine lances sustinet ...“

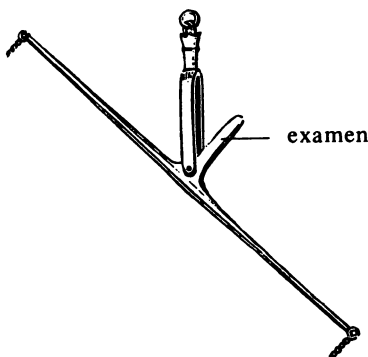

exedra –ae, f. / exhedra –ae, f.

est locus apertus in porticu (*porticus*) vel etiam sub divo, in quo multae circum positae sellae colloquendi causa.

Vitruvius in descriptione aedificii cuiusdam (5, 11, 2):

„constituuntur in tribus porticibus exedrae spatiosae, habentes sedes, in quibus philosophi, rhetores reliquique, qui studiis delectantur, sedentes disputare possint.“

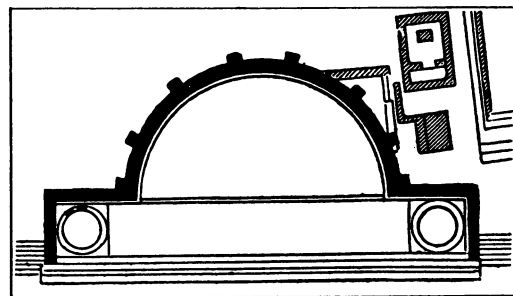

***facsimile —is, n.

facsimile est substantivum derivatum a sententia: „fac simile!“ = imitare! facsimilia sunt opera iterum excussa iisdem typis (*typus*) iisdemque imaginibus quam *prototypus*. saepe *incunabula* hoc modo denuo imprimuntur.

De Insulis inuentis

Epistola Cristoferi Colom (cui etas nostra multū debet: de Insulis in mari Indico nup inuētis. Ad quas perquirendas octauo antea mense: auspicijs et ere Inuicissimi Ferdandi Hispaniarum Regis missus fuerat) ad Adag-nificum dñm Raphaelē Sangio: eiusdē serenissimi Regis Thesaurariū missa. quam nobilis ac litterat⁹ vir Alexander d' Loſco: ab Hispano ydeomate in latinū conuertit: tercio kl⁹ adaj. ad. cccc. xcij. Pontificatus Alexandri Sexti Anno Primo.

Quoniam susceptę prouincie rem pfectam me psecutum fuisse: gratū tibi fore scio: has pstrui cęrare: que te vniuscuiusq; rei in hoc nostro itinere geste inuenteq; admoneāt. Tricesimoter tio die postq; Gadibus discessi: in mare Indicū perueni: vbi plurimas Insulas innumeris habitatas hominib⁹ repperi: quaz oīm p felicissimo Rege nostro: pꝛiconio celebrato ⁊ vespilijs extensis: cōtradicente nemine possessio nē accepi. pꝛimeq; earum: diui Saluatoris nomen imposui (cuius frat⁹ auxilio) tam ad hęc q; ad ceteras alias puenim⁹. Eam vero Indi

facsimile epistulae Cristofori Columbi, quae primum imaginibus illustrata Basileae anno 1493 in aedibus Olpe excussa est. prima notitia novarum a Columbo inventarum insularum novi mundi Latine divulgata est!

fastigium —i, n.

fastigium est summitas tecti, cacumen a latitudine surgens et paulatim in acumen desinens. primum templa fastigia habebant, postea a sacris aedibus transiit ad Caesarum domos, postquam divinos honores Romani illis tribuere coeperunt.

Caesar, B. G. 7, 69:

„colles ... pari altitudinis fastigio oppidum cingebant“, quo loco translate dicitur fastigium de summitate collium et montium.

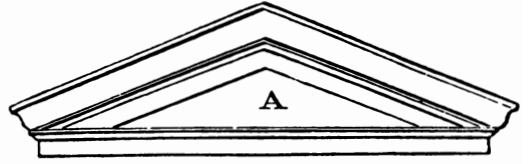

fastigium

A = tympanum

favus —i, m.

est locus, quem apes fingunt multicavatum et cera, cum singula cava sena latera habeant, quot singulis pedes dedit natura.

Cicero, off. 1, 44, 157:

„apium examina non fingendorum favorum causa congregantur, sed cum congregabilia naturā sint, fingunt favos.“

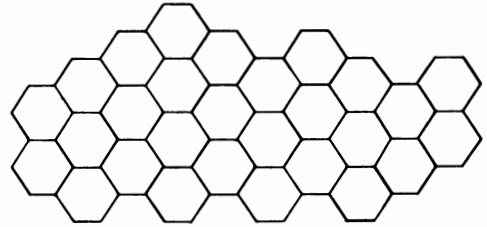

fax —cis, f.

est frustum ligni ut pinus, taedae, laricis cerā aut oleo iniunctum, aut etiam per se solum, vel alterius materiae igni concipiendo aptae, ad lumen faciendum ignemque circumferendum, frequenti usu praesertim apud rusticos.



ferculum –i, n.

a) a verbo „fero“, est machina ferendo apta.
b) est gestamen, quo signa (*signum*) deorum in pompa circensi vehebantur, aut quo in triumphis spolia hostium, simulacra oppidorum captorum aut regionum portabantur.



ferculum in triumpho latum

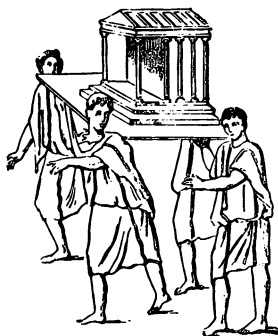

ferculum
in pompa
deorum
portatum

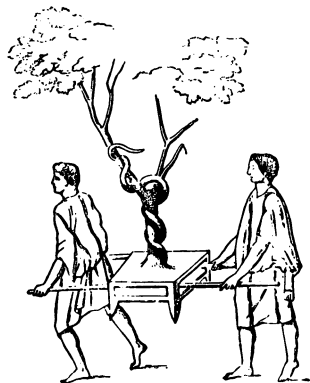

fibula –ae, f.

est quiddam rem unam adnectit, vel uni cum altera colligandae inservit. est instrumentum, quo vestes subnectuntur.

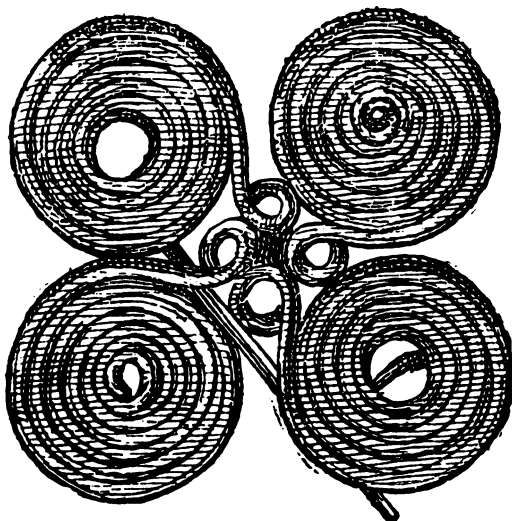
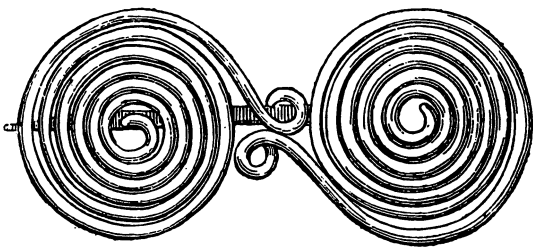

fibulae spiris ornatae

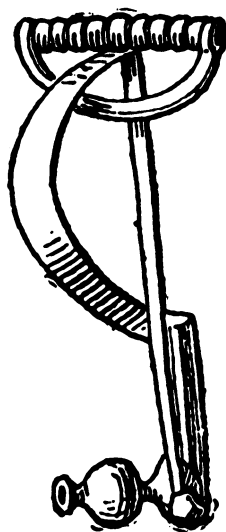

fibula arcuata

fidicen –inis, m. (fidicina –ae, f.)

fidicen est is, qui fidibus canit; generatim dicitur pro citharista. usurpatur etiam pro poeta lyrico:

Horatius, carm. 4, 3, 23:

„Romanae fidicen lyrae“

fides, –ium, f. pl.

a) sunt chordae seu nervi lyrae.

b) fides dicitur instrumentum musicum, in chordis habens harmoniam (lyra, cithara).



filum –i, n.

filum est quod ex lino lanave trahendo ducitur; itemque aliud quidlibet huic simile.

formula: filum in acum (acus) conicere.

a poetis filum saepe dicitur stamen vitae, quod nere Parcae dicuntur.

filum Ariadnae:

Ariadna, ut fabula narrat, Thesei amore capta, qui ab Atheniensibus ex foedere cum Minoe in Cretam Minotauro devorandus missus fuerat, ei arma et filum dedit, ut labyrinthi (labyrinthus) vias signaret et monstro interfecto incolumis evaderet.

fiscus –i, m.

fiscus est vas vimineum, iunceum, aut ex simili materia. mos fuit pecuniam in fiscos condere:

Phaedrus, 2, 7:

„multos ferebat fiscos cum pecunia.“

fiscus dicitur etiam de ipsa pecunia, praesertim de pecunia publica.

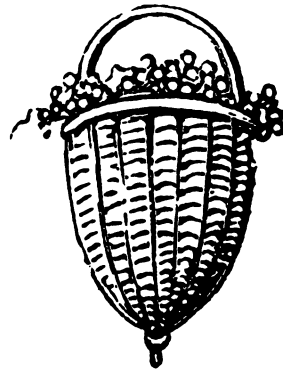

flabellum –i, n.

deminutivus a nomine „flabrum“ = parvum flabrum, instrumentum, quo fit ventilatio ad refrigerandum, vel ad ignem excitandum.



varia flabella e pennis facta

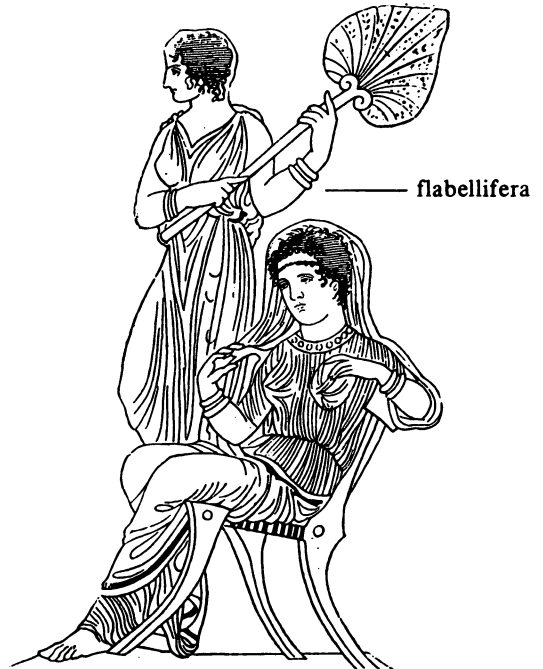

flagellum –i, n.

deminutivus, a nomine „flagrum“, est lorum seu aliud quodvis flexile, verber, seu potius instrumentum pluribus loris iunctum, ac saepe scorpionibus sive aculeis munitum, quo servos nudatos caedere solebant.



flamen –inis, m.

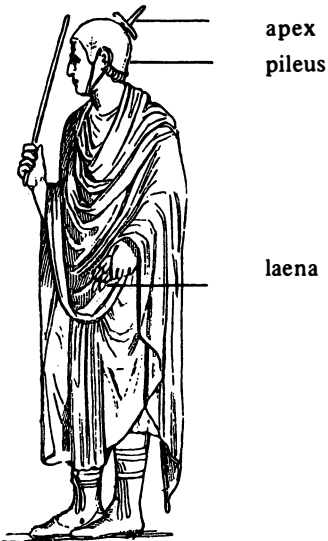

sacerdos apud Romanos. flamines appellabantur cognomine eius dei, cuius sacra curabant, ut flamen Dialis (= Iovis), Martialis, Quirinalis,

Floralis, Vulcanalis etc. suberantque omnes pontifici maximo.

flamen caput pileo cum apice tegebat, supra togam laenam purpuratam gerebat.

foculus –i, m.

est parvus focus.

dicitur etiam de ara et de foculo, qui vel fictilis vel aeneus, vel argenteus, et duabus ansis (ansa) instructus circumferri solebat sacrificandi causa.

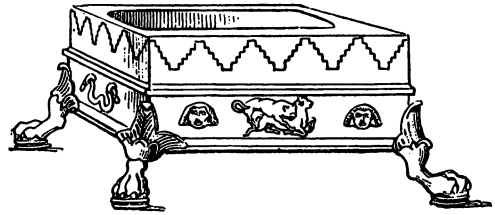

foculus qui portatur

focus aut foculus ponitur etiam pro vase ferreo, aeneo aut fictili, in quo cibi coquantur aut quo homines calefiabant.

Plinius, H. N. 35, 10, 36 (89):

„Arrepto carbone extincto e foculo imaginem in pariete delineavit.“

focus –i, m.



a) stricto sensu est id, quo ignis servatur, sive sit stabili loco in aedibus, sive qui possit quolibet circumferri.

b) speciatim de *ara*, seu potius de foculo (*foculus*), qui vel fictilis, vel aeneus, vel argenteus, et duabus ansis (*ansa*) instructus circumferri solebat sacrificandi causa. hinc saepissime „ara focusque“ simul nominantur a Latinis scriptoribus.

Cicero, Nat. Deor. 2, 27, 67:

„vis autem Vestae ad aras focosque pertinet.“

c) focus sumitur etiam pro privata domo:

Horatius, Ep. 1, 14, 2:

agellus ... habitatus quinque focus ...

follis –is, m.

a) est sacculus coriaceus, qui vento aliae re impletur. e quo follis dicitur instrumentum, quo atrahitur ventus atque emittitur ad ignem excitandum.

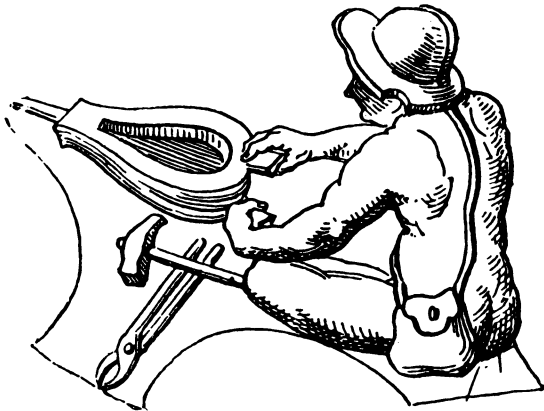

lucerna fictilis cuius elychnium folle excitatur

b) item est pilae (*pila*) genus omnium maximum, constans ex aluta vento inflata, quod etiam hodie Italis plurimo est in usu.

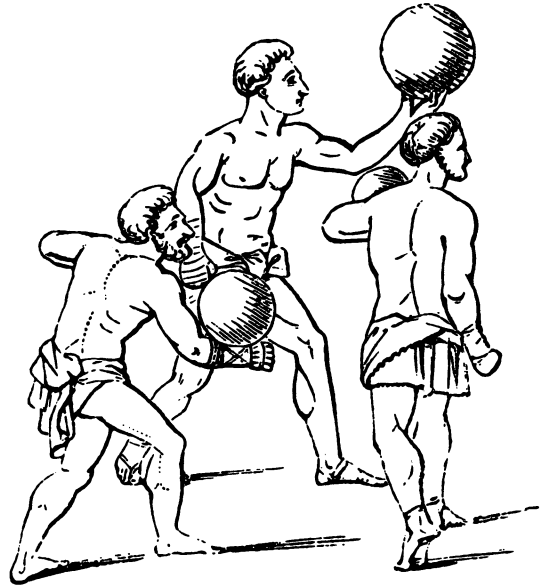

fons –ntis, m.

a) est locus, unde perennis aqua erumpit et ipsa aqua iugis erumpens.

Cicero, Verres 4, 53, 118:

„fons aquae dulcis, cui nomen Arethusa est, incredibili magnitudine, plenissimus piscium.“



b) fons dicitur ipsa constructio fabricae, unde aqua profluit.

c) fons per metaphoram etiam est origo, principium, causa, unde quippiam abunde suppetit.

Cicero, Acad. post. 1, 2, 8:

„meos amicos, in quibus est studium, ad Graecos ire iubeo, ut ea a fontibus potius hauriant, quam rivulos consecentur.“

fornax –acis, f.

in fornacibus coquuntur vasa fictilia, figurae fictiles, metalla in fornace aerariā, calx in fornace calcariā.

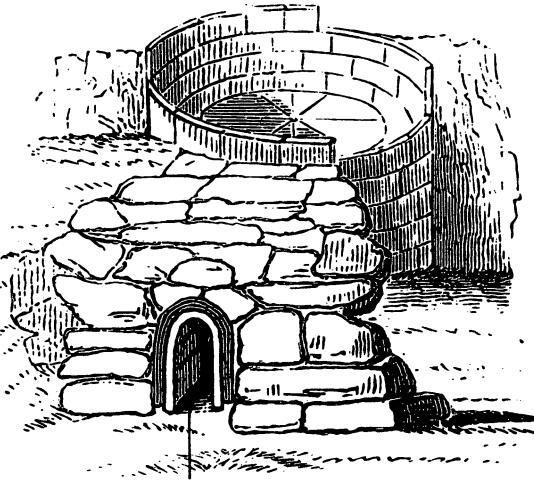

praefurnium

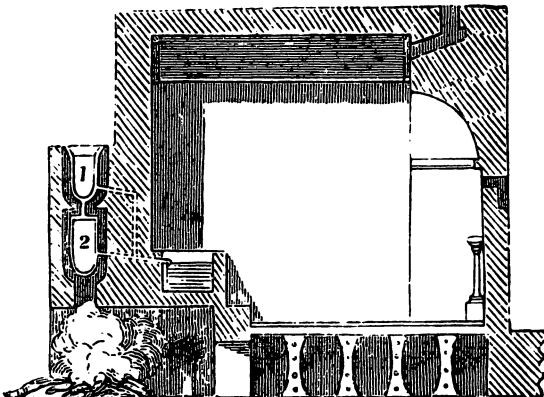

fornacula

hypocaustum

fornacibus aut fornaculis etiam calefiunt hypocausta balnearum (*balneum*) domuumque.

fornix –icis, f.

a) est structura in arcūs modum curvata et convexa, quae plures arcus complectitur, quemadmodum est etiam *testudo*, quae fuit quaedam *camerae* species.

b) per similitudinem fornices dictae sunt *cellae* concameratae, vel *pergulae*, in quibus prostabant meretrices. verbum derivatum: fornicari = scortari.

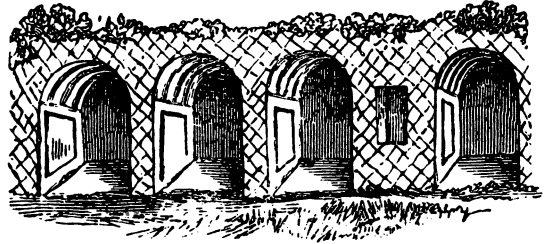

Fortuna –ae, f.

dea est fati humani, quod saepe rotae assimilatur. rota Fortunae refertur ad varietatem instabilitatemque Fortunae, quae rotae insistere dicitur.

Tibullus, 1, 5, 70:

„versatur celeri Fors levis orbe rotae.“ (*rota*)

fovea –ae, f.

fovea est fossa brevis, profunda et in summo tantum patens: quales sunt, quibus fronde obtectis, bestias feras decipiunt, et quibus sepeliuntur cadavera.

Horatius, Ep. 1, 16, 50:

„cautus enim metuit foveam lupus ...“

dictum: „paene in foveam incidi“ = paene in periculo perii.

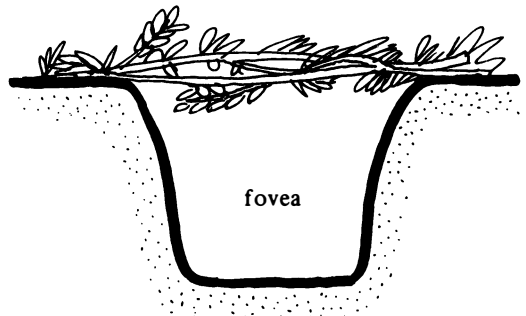

fovea

frenum –i, n.

frenum est instrumentum, quo equorum ora coercentur; lorum freno alligatum, quo equi reguntur, *habena* dicitur.

Horatius, Ep. 1, 10, 36:

„imploravit (equus) opes hominis frenumque
recepit.“

proverbium: „frenum mordere“ est se ferocem et recusantem ostendere.

verbum: frenare = frenum imponere.

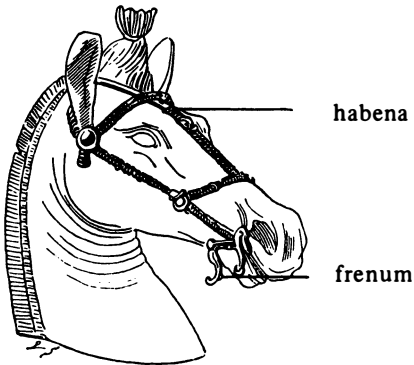

fretum –i, n.

a) sunt maris angustiae, e. g. fretum Siciliense, inter Siciliam Italiamque situm; fretum Gaditanum est fretum nostri maris et Oceani.

b) speciatim absolute dicitur de freto Siculo, quod primum omnium fuit Romanis cognitum et maxime frequentatum.

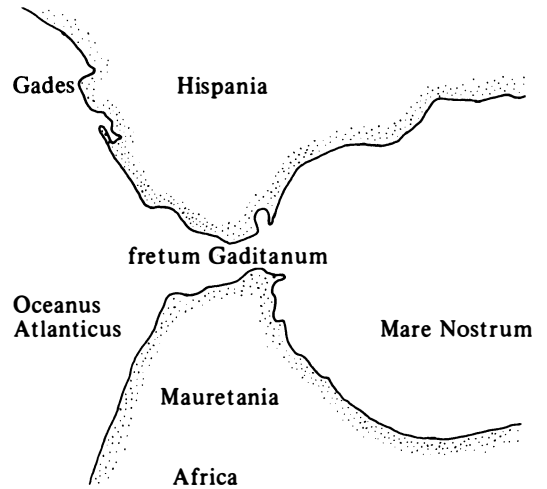

frigidarium –i, n.

est primum conclave balnei (*balneum*) Romani aut thermarum (*thermae*) prope *apodyterium*, aquā frigidā praeditum, ubi post sudationem

intrabant. saepe in frigidario *piscina* frigida erat, quae *baptisterium* vocatur.

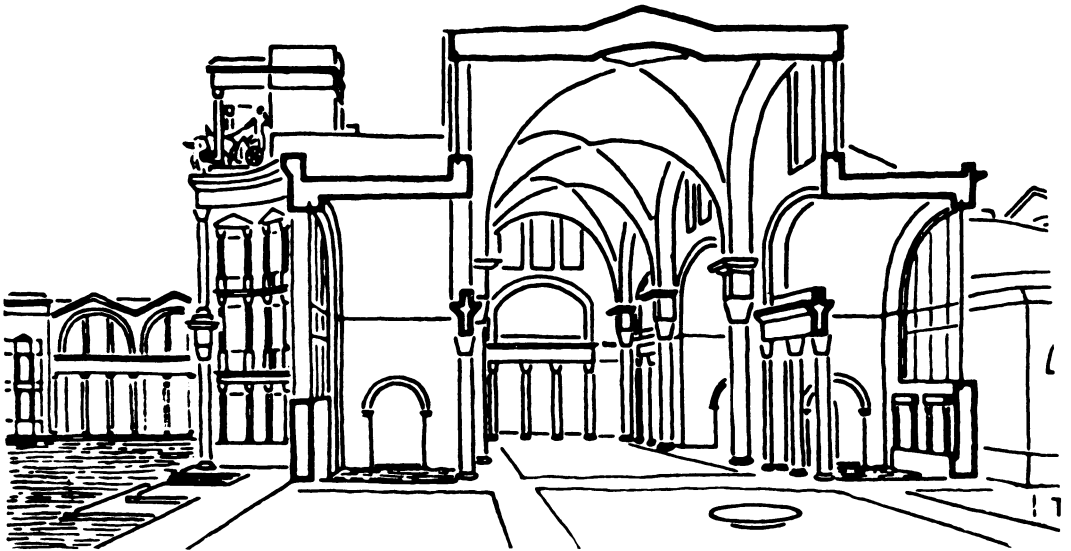

sectio frigidarii Thermarum Diocletiani. Hodie in hoc frigidario est ecclesia, a Michelangelo extracta, quae Sancta Maria Angelorum (italiane: degli Angioli) nominatur.

fritillus –i, m.

est turricula rotunda, per quam tali mittuntur, ne digitis ita a quoquam componi possint ut cadant ad iacentis voluntatem: qui fritillus intus trochleatim erat effectus, certosque habebat excisos gradus, quibus tali (*talus*) impingentes subsilirent cum sonitu.

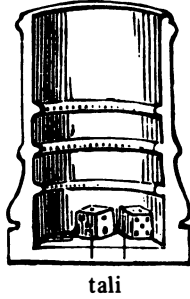
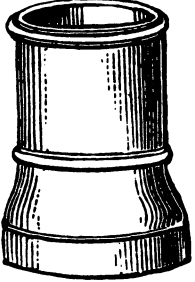

tali

fucus –i, m.

a) est color purpuram imitans. quicumque color non sincerus et naturalis, sed facticius et arte inductus ad verum imitandum, qualis est v. gr. quo mulieres faciem tingunt ad augendam pulchritudinem.

Plautus, *Most.* 275:

„vetulae, edentulae, quae vitia corporis fuco occulunt.“

formula: fuco illinere aliquid.

b) fucus dicitur de quovis ornamento extrinseco, levi, simulato, et in speciem quidem pulchro, sed quod facile deprehendatur.



fullo –onis, m.



est qui vestes pedum insultu cogit et densat, easdemque purgat, maculis liberat, polit et creta candefacit.

fullonica, –ae, f. aut fullonium est officina fullonis.

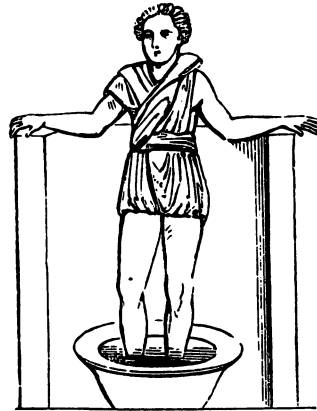

funale –is, n.

est funalis cereus, seu funis pice, sebo, vel cera illitus.

Vergilius, *Aen.* 1, 727:

„... et noctem flammis funalia vincunt.“



Victoria in imagine sepulcrali duo funalia ostentans

funalis

sc. equus sub curru dicitur, qui non ad iugum sed ad latera iungitur, duobus iugalibus mediis: qui non iugo sed fune lorove alligatur.

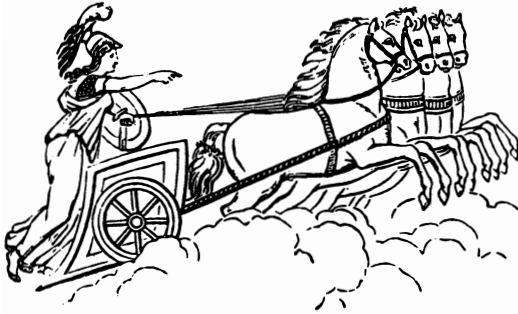

equus funalis (dexter) in quadriga Herculansensi

funambulus –i, m.

est qui per funem ambulat.

Suetonius, Galba 6:

„novum spectacula genus, elephantos funambulos edidit.“

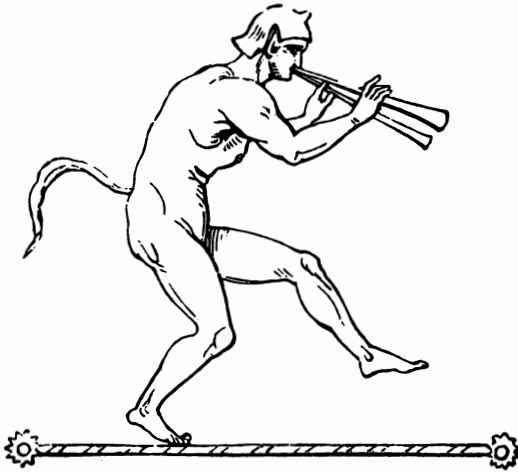

funambulus in pariete Herculanei depictus

funda –ae, f.

est instrumentum e duobus funiculis, latiore sinu in medio, in quo lapis vel plumbea glans imponitur, circumactisque circum caput funiculis, et altero eorum remisso, magna vi longissime iacitur.

Caesar, B. G. 4, 25:

„ad latus apertum hostium constitui atque inde fundis, sagittis, tormentis hostes propelli ac summoveri iussit.“



funda

funditor in
columna
Traiani

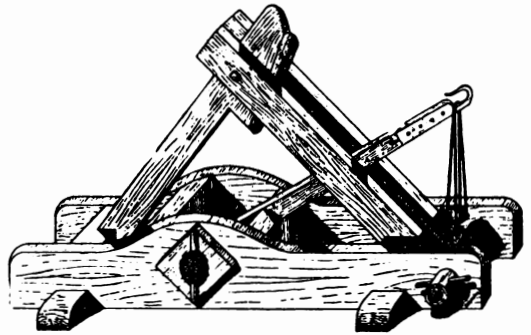

funda librilis est machina bellica, qua librilis saxa iaciebantur

funus –eris, n.



est pompa, quae fit in exsequiis mortuorum, a funalibus (*funale*) sive funibus accensis, quia cadavera noctu efferebantur cum faculis (*fax*), propter sacrorum celebrationem diurnam. interdum dicitur de ipso corpore vitā functo, aut de ipsis Manibus et umbra mortuorum, ut imagine ex opere caelato sumptā monstratur. adi. funebris, -e = ad funus pertinens, ex. gr. epulum funebre, vestimentum funebre. funebria, -ium, n. sunt ipsa iusta funebria, seu funeris apparatus.

furca -ae, f.

furca est instrumentum bicornis, quo stramenta moventur vel feruntur.

proverbium: „naturam expellas furca, tamen usque recurret.“ (Horatius, ep. 1, 10, 24)



furnus -i, m.

est locus, in quo panis coquitur. latiore sensu est quidquid calefaciendi inservit.

Plautus, Cas. 309-311:

„... in furnum calidum condito, atque ibi torreto me pro pane rubido, hera.“

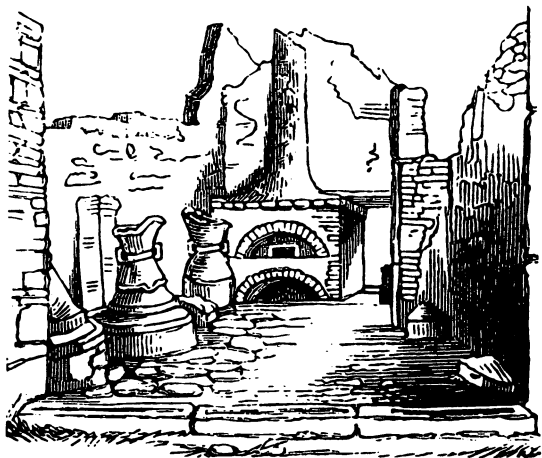

fusus -i, m.

est instrumentum, quod mulieres nendo (nēre, neo, nevi, netum) digitis volvunt.

Ovidius, Met. 6, 22:

„levi teretem versabat pollice fusum.“

a poetis fusi tribuuntur Parcis (*Parcae*), quae nere dicuntur humanae vitae stamina (= fila).



imago in vase picto Graeco: puella pollice manus sinistrae fusum versat, dextra filum net

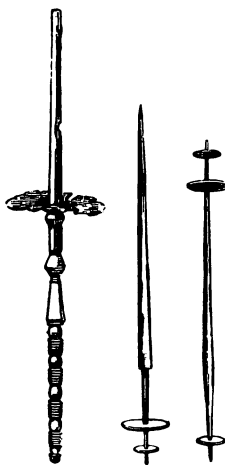

fusi aenei Romani

galea –ae, f.

cassis, tegumentum capitis ad munimentum in bellis contra ictū et tela.

cristatae galeae, quae speciem magnitudini corporum adderent (Livius 9, 40).

(crista proprie est apex in vertice gallinacei generis).

centuriones cristatas galeas portabant.

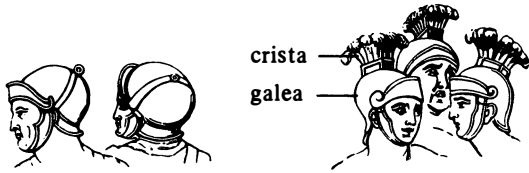

crista

galea

gemma -ae, f.

a) gemma est oculus vitis vel alterius arboris, qui primo emittitur.

b) translate gemma est lapillus pretiosus, praecipue qui anulo includitur.

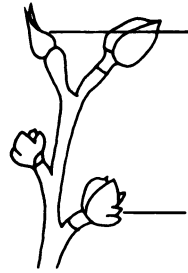

gemma foliorum

gemma floris

Gallia Romana

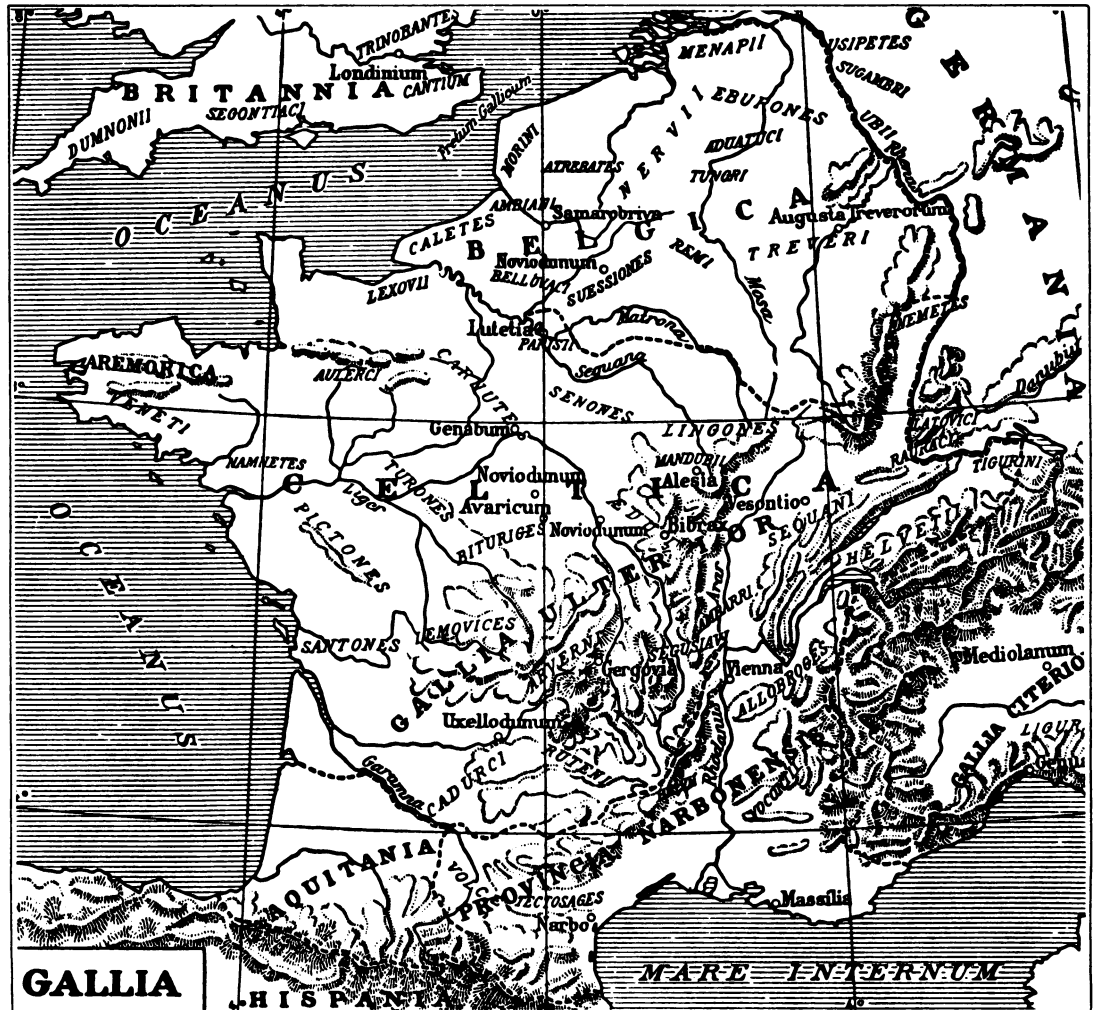

gens -ntis, f. (gentium)

est multitudo hominum, quae ex pluribus familiis constat, quaeque ab eodem progenitore descendunt. sic omnes Corneli unius esse gentis dicebantur, quia omnes uno appellabantur nomine, sed diversarum erant familiarum, quae cognominum varietate distinguebantur: gens enim Cornelia dividebatur in Cinnae, Dolabellae, Lentulorum, Scipionum, Sullae etc.
 adi. gentilis, -e est ex eodem genere ortus, seu qui est eiusdem gentis.

sequiore aeo gentiles a Romanis dicti sunt barbari, et quicumque non lege civili Romanorum, sed inculto iure gentium vivebant: gentilis opponitur vocabulo civilis, qui in civitatem receptus est. a Iudaeis et Christianis gentiles nominabantur, qui non participes erant verae religionis. (pagus, paganus)

geometria -ae, f.

lineae:

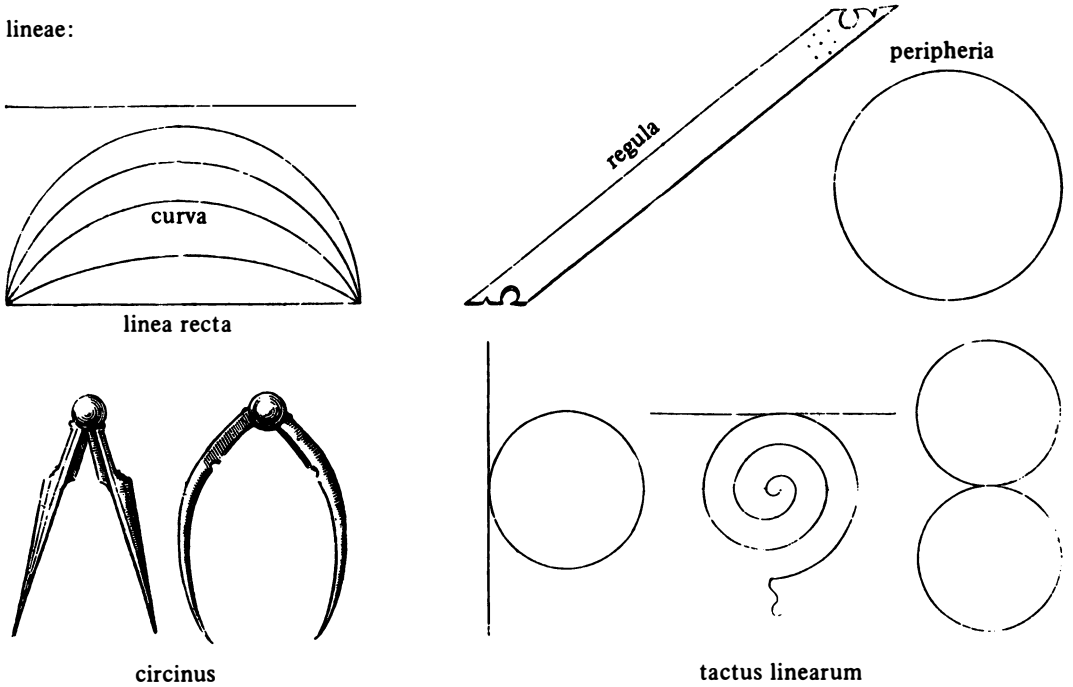

flexuosa

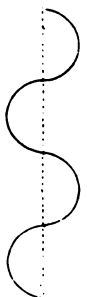

conchalis

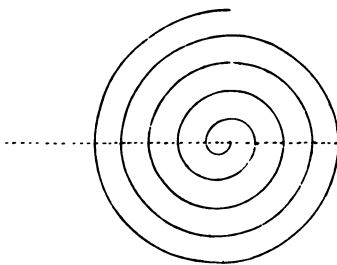

ovalis

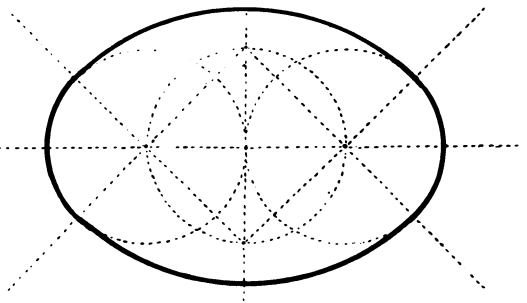

ovalis

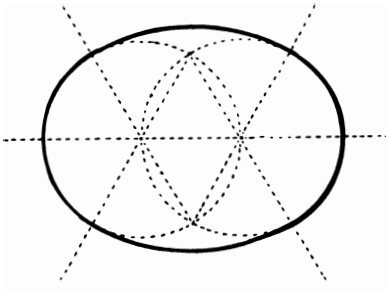

vere ovalis

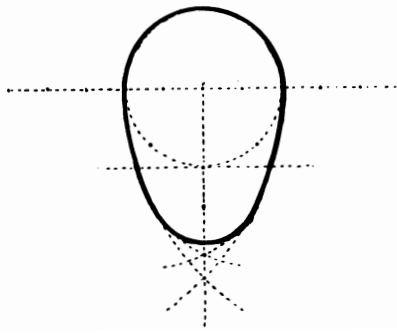

perpendicularis

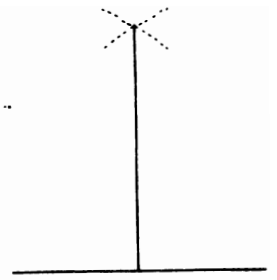

inclinata

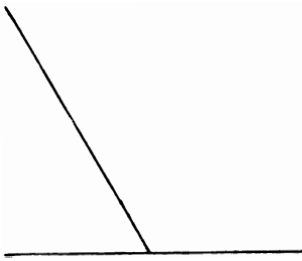

parallela

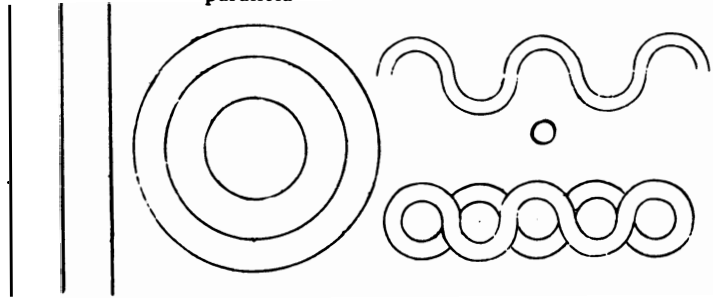

anguli:

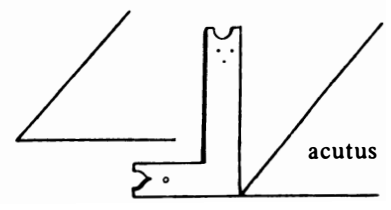
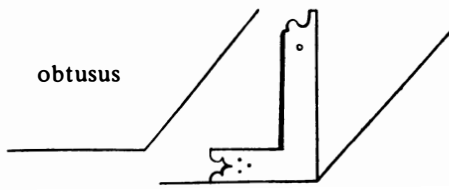
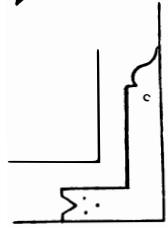
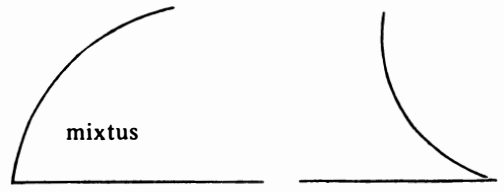
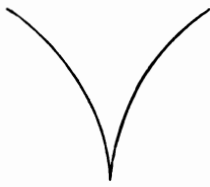
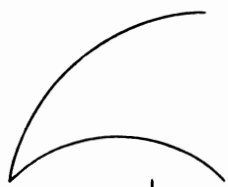
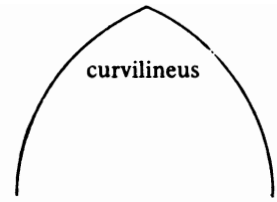
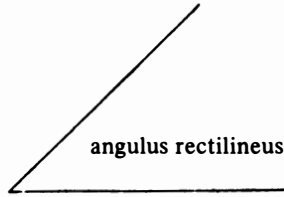
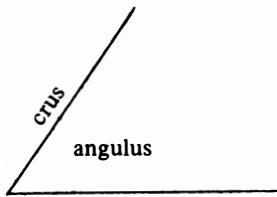

genera triangulorum:

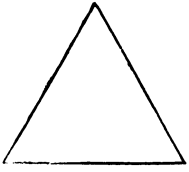

aequilaterum

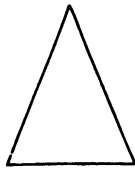

aequicrurum

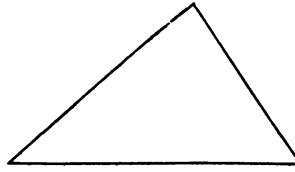

scalenum

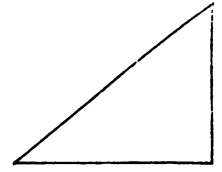

rectangulum

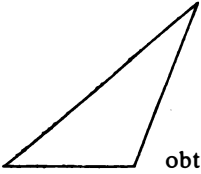

obtusangulum

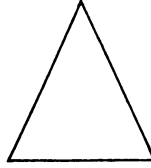

acutangulum

genera quadrangulorum:

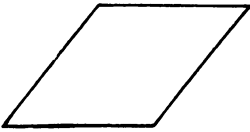

rhombus



rhomboides



oblongum

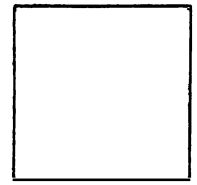

quadratum

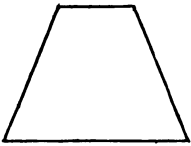

trapezium

circulus eiusque partes:

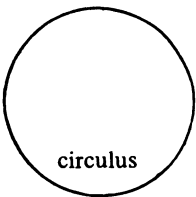

circulus

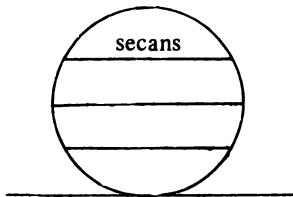

secans

tangens

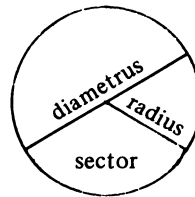

diameter

radius

sector

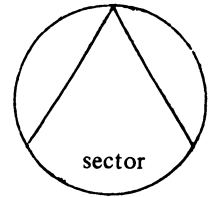

sector

peripheria

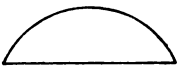

segmentum minus

segmenta similia

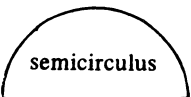

semicirculus

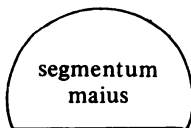

segmentum maius

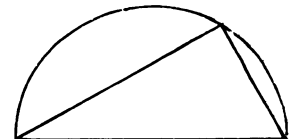

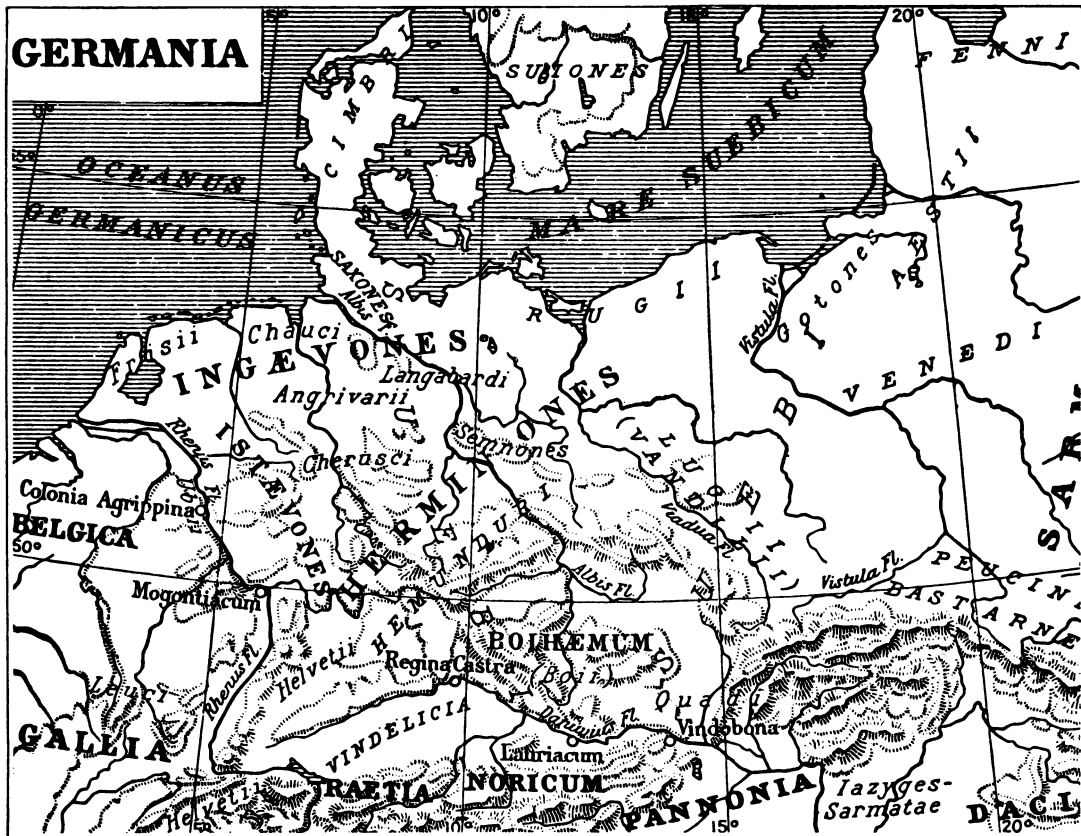

gluten –inis, n. vel glutinum, –i, n.

est materia viscosa ac tenax, qua res coniunguntur.

verba derivata: ad-glutino
con-glutino

glutinator, –oris, m. est is, qui chartas chartis attextit in longitudinem, ut volvi possent et **volumen** efficere.

graphium –i, n.

graphium est stilus ferreus, quo veteres in

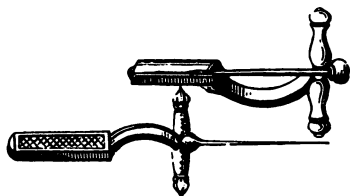

ceratis tabulis solebant scribere; a graeco grapho = „scribo“.

gremium –i, n.



gremium est locus inter complexum ventris et feminum, quem sedentes efficimus: quo loco matres nutricesque excipiunt infantes. differt a sinu (*sinus*), qui est intra pectus et brachia (sed nihilominus alterum pro altero non raro ponitur).

Cicero, Div. 2, 41, 86:

„puer in gremio matris sedens, mammam appetens.“

gryps –pis, m. / gryphus –i, m.

est avis fabulosa, animal quadrupes et pennatum, omni ex parte leo, alis tantum et facie aquilae simile.

Plinius, Hist. Nat. 7, 2, 2, (10) narrat ex aliorum sententia, esse Arimaspos, homines uno oculo in fronte insignes, qui cum his bellum assidue gerant, eruentibus ex cuniculis (*cuniculus*) aurum, et mira cupiditate custodientibus, Arimaspiis vero rapientibus.



gubernator –oris, m.

est rector navis.

Cicero Senect. 6, 17:

„gubernator clavum tenens, sedet in puppi quietus.“ gubernaculum est *clavus* in puppi navis, quo ipsa regitur.

Seneca, de gubernaculo, ep. 90, 24:

„exemplum (scilicet gubernaculi) a piscibus tractum est, qui cauda reguntur et levi eiusdem

in utramque momento velocitatem suam flectunt.“

vox „gubernator“ a Graeco *kybernetes* derivatur et saepe in vetustis monumentis „gubernator“ scribitur.

***cybernetica (sc. ars) est ars automatarie regendorum motuum machinarum, inventa et denominata a Norberto Wiener.

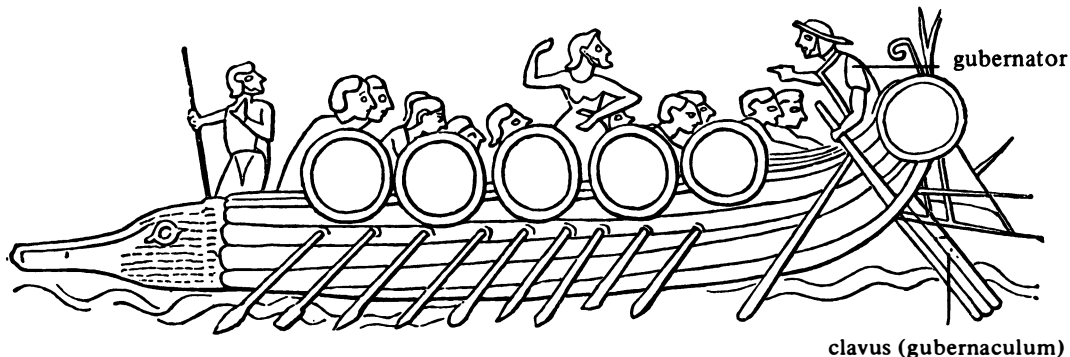

gurgis –itis, m.

gurgis est locus in flumine profundus, in quo aqua vertitur (*vertex*), translate:

Cicero, Verr. 3, 23, 9:

Verres „... gurgis vitiorum turpitudinumque omnium.“

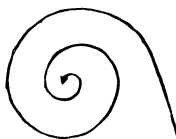

gutta –ae, f.

a) gutta est minima pars aquae vel alterius materiae liquidae.

Ovidius, Pont. 4, 10, 5:

„gutta cavat lapidem, consumitur anulus usu.“

b) in architectura guttae dicuntur ornamenta sub triglyphis in Dorico genere, instar guttarum pendentia.

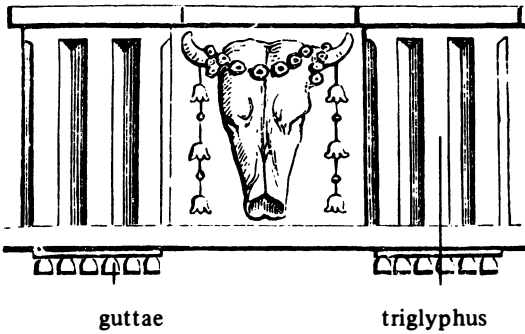

gyrus –i, m.

gyrus est circumventio in orbem, ambitus, circuitus, circulus.

***gyrus est modus solvendi pecuniam non praesente pecunia, sed perscriptione factus.

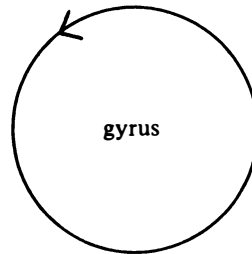

habena –ae, f. (saepe: habenaе, –arum)

habena est lorum freno (*frenum*) alligatum, quo equi reguntur.

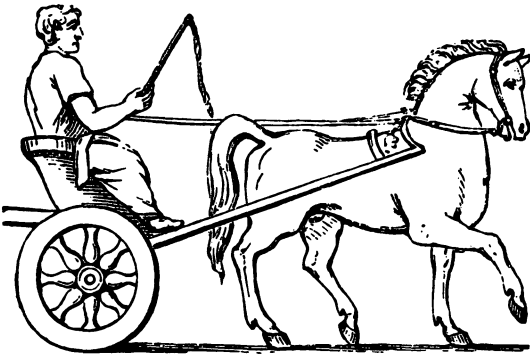

opus caelatum Musaei Veronensis

hamus –i, m.

a) hamus est parvus uncus ferreus.
b) speciatim hamus est uncus ferreus, ex quo piscatores (*piscator*) escam suspendunt, quam dum captat, piscis ore capiatur.

Ovidius, *Heroid.* 18, 13:

„Nunc volucrem laqueo, nunc piscem ducitis hamo.“

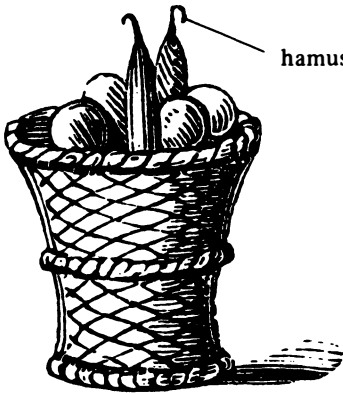

hamus textorius

harundo –inis, f.

est aquaticus frutex in longam altitudinem crescens, cortice lignoso et inarescente, fissili, praeacutā semper acie. Harundinibus veteres usi sunt ad casas (*casa*) contendas.

Vitruvius, 2, 1, 3:

„alii ... luteas glebas arefacientes struebant parietes (*paries*), vitandoque imbres (*imber*) et aestūs tegebant harundinibus et fronde.“
saepe etiam *fistula* pastoris harundo nominatur. harundine etiam *piscatores* pisces capiunt, ut videtur in imagine Pompeis inventā.



piscator

hebdomas –adis, f. (aut hebdomada –ae, f.)

a Graeco hebdomos = septimus. hebdomas est spatium septem dierum deis Planetarum dicatum.

**septimana = it. settimana, fr. semaine, hisp. semana.

series septem dierum hebdomadis haec est: Solis dies, Lunae dies, Martis dies, Mercurii dies, Iovis dies, Veneris dies, Saturni dies.



Hecate —es, f.

est Iovis et Latonae filia, soror Apollinis. est tricorpor et triceps, magicarum artium magistra ac fascinationum praeses, cincta latantium canum turmā; noctu stans in triviis (*trivium*) vel prope sepulcra et ubi loca sunt caedibus contaminata.



Hecate triformis

helcium —i, n.

est funis, quo equi vel homines currūs, naves (*navis*) oneraque trahunt.

cymba



opus caelatum e Gallia Transalpina, duo helcarios monstrans

helcarius, —i, m., est is, qui funibus sive helciis (vide supra) cymbas adverso flumine trahit.

Helvetia Romana

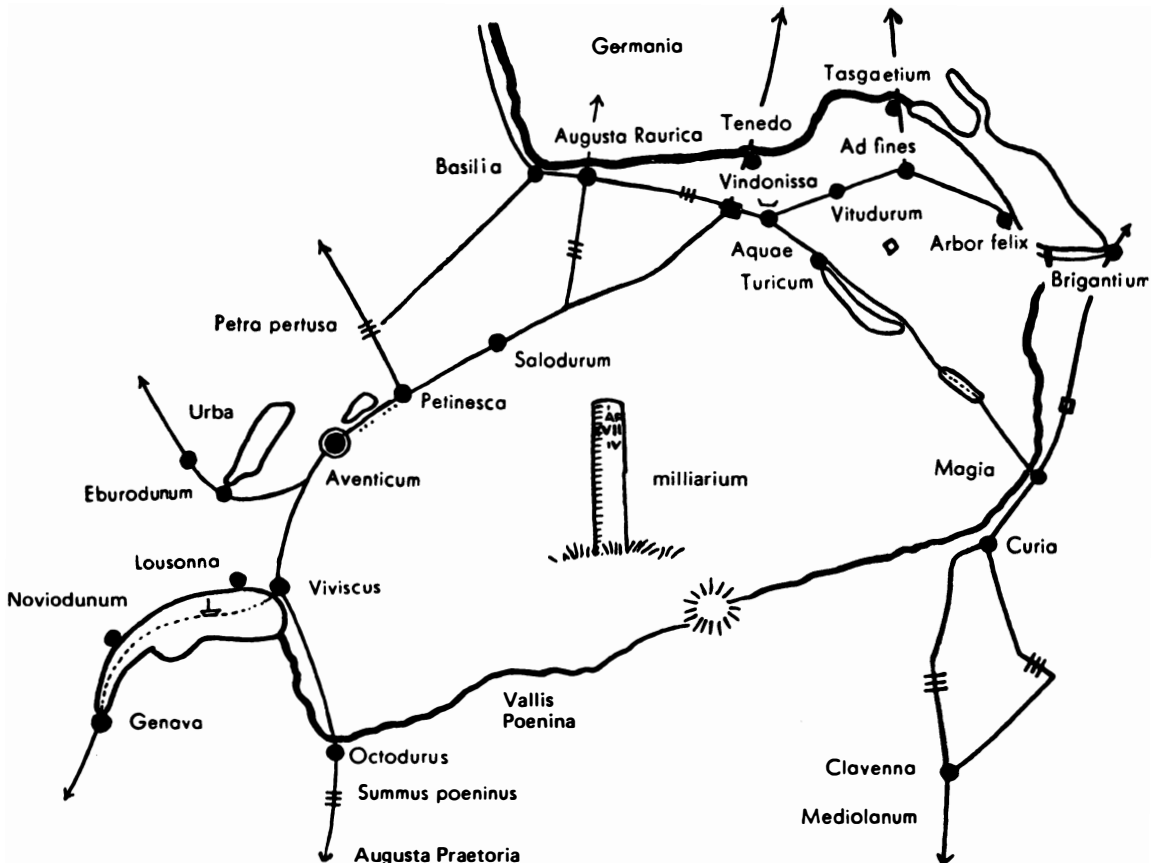

Hesperides –um, f. pl.



vas figuratum
Rubi inventum,
hortum Hesperidum repraesentans

filiae Hesperii; finguntur hortos (*hortus*) amoenissimos possedisse in extrema Africa, ubi erat auriferum nemus cum mälis aureis, quae a pervigili dracone (aut serpente) custodiebantur. Hercules tamen, eo penetrans Eurysthei iussu, draconem occidit et aurea mälä ad eum attulit.

hippocampus –i, m.

est piscis marinus parvus, capite et iuba instar equi. item est marinum monstrum, equi simile, quo fabulantur ad currum iuncto vehi maris numina.

Tritones Nereidesque hippocampis per mare vehuntur deos marinos comitantes.



Hispania Romana



Horae –arum, f. pl.

sunt deae, quae horis praesunt, Iovis ac Themidis filiae, apud mythologos communiter tres Horae sunt tribusque temporibus anni respondent.



tres Horae in opere caelato arae cuiusdam villae Borghese; exemplar huius operis caelati aetate Periclis (V. saeculo a. Ch. n.) perfectum est prima Hora, quae flores portat, respondet veri, secunda uvis autumnum indicat, tertia manu sinistra spicam frumenti gerens est aestas. deest quartum tempus anni, hiems.

horologium –i, n.

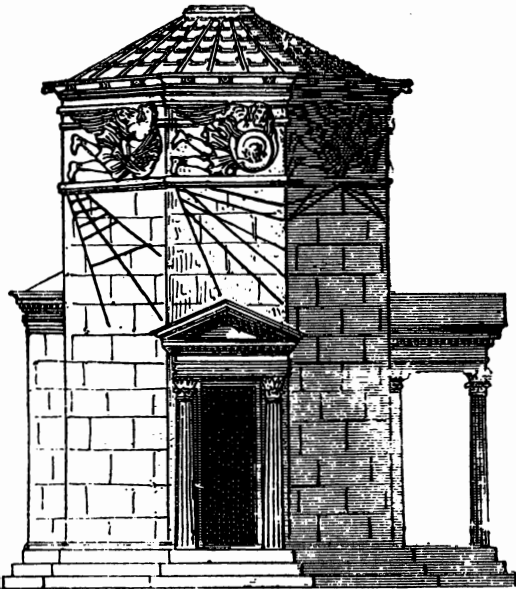

imago Turris Ventorum, quae dicitur, Athenis etiam hodie servatam, monstrat, cuius latera solaris praedita sunt

horologium est instrumentum, quo tempus diei definitur, sive horologio solario sive clepsydra: in clepsydra aqua e superiore vase in inferius vas guttatim cadens tempus indicat.

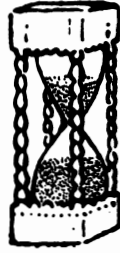

hortator –oris, m.

est qui hortatur et suadet, ut aliquid fiat. hortator remigum (vide imaginem) remigibus baculo numerum indicat. Plautus, Merc. 695/96: „quasi in mari solet hortator remiges hortarier.“

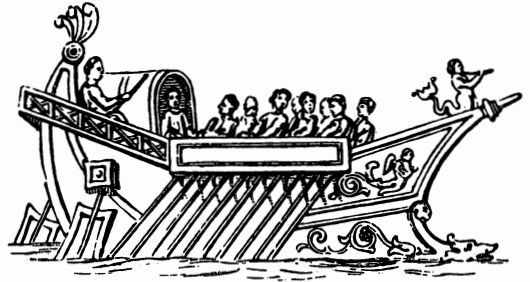

hortus –i, m.



hortus Romanus maceria saeptus, duobus fontibus cum siphunculis vel siphonibus (sipho) praeditus

est locus maceriā aut saepe (*saepes*) clausus, in quo olera cibi causā coluntur; item in quo arbores, poma, flores voluptatis causa coluntur. maceria aut saepes hortum ab incursu hominum pecudumque munit. hortorum culturam monachi Christiani a Romanis acceptam nobis tradiderunt.

hostia –ae, f.

est vivum animal quod in sacris mactatur in honorem deorum. „purae hostiae“ dicuntur, quae ad sacrificium idoneae sunt.

Caesar, B. G. 8, 51:

„Exceptus est Caesaris adventus ab omnibus municipiis et coloniis incredibili honore atque amore ... hostiae omnibus locis immolabantur.“



hostia (ovis)

hypocaustum –i, n.

est vaporarium, locus in thermis concameratus et fornicatus (*camera, fornix*), qui igne calefit.

Vitruvius, 5, 10:

„est animadvertendum, uti caldaria muliebria viriliaque coniuncta et in iisdem regionibus sint collocata. sic enim efficietur, ut vasaria et hypocaustis communis sit eorum utrisque. aenea supra hypocaustum tria sunt componenda, unum caldarium, alterum tepidarium, tertium frigidarium.“



tria vasa aenea (aqua calida, tepida, frigida)

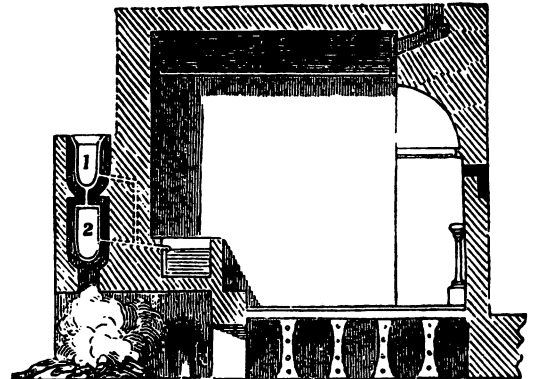

Ianus —i, m.

est totius mundi custos, caeli ianuis praesidet, omnium aedium foribus praeses est constitutus, item viis omnibus tam urbanis quam rusticis; ille caelum, aerem, terram, aquam, res omnes huius universitatis claudit et aperit, pacem et bellum in sua potestate habet.

Ianus biceps aut bifrons nominatur, i. e. duo capita aut duas frontes habet, quod tempus praeteritum et tempus futurum simul spectat, tamquam in limine temporum stans, ut in hoc nummo Romano delineatus est.

a Iano primus mensis anni mensis Ianuarius dicitur. de Iano Ovidius (Fast. I, 117/18) haec dicit:

„quidquid ubique vides, caelum, mare, nubila,
terras,

omnia sunt nostrā clausa patentque manu.“

Iani templum in Foro Romano in bello apertum, in pace clausum erat.



imago —inis, f.

a) est simulacrum, species, exemplar, alicuius rei repraesentatio.

b) item de imagine hominis aut rei, quae a phantasia excitatur, cuiusmodi sunt quae in somniis apparent, mortuorum umbrae, etc.

ius imaginum: apud Romanos qui maiorum suorum habuerunt imagines, ii erant nobiles; qui suas tantum, ii novi; qui nec maiorum, nec suas, illi demum ignobiles appellati sunt.

imaginem porro sui ponere non temere omnibus licuit, sed iis tantum, qui magistratus curules gessissent. has imagines primi patricii posuerunt, quod iis primis curules magistratus patuerunt, unde ius imaginis fuit.



huiusmodi imaginibus ornabant atria aedium easque in funebribus pompis proferebant circumferebantque. (funus) imaginarius, vel imaginifer est qui imaginem imperatoris fert.



imaginarius

verbum imagine: imaginari est rei alicuius, quae facta sit vel fieri possit, vel etiam quae fieri non possit, similitudinem mente concipere. Quintilianus, 9, 2, 41:

„nec solum quae facta sint aut fiant, sed etiam quae futura sint aut futura fuerint, imaginamur.“

impedimenta –orum, n. pl.

impedimentum est id, quo quis impeditur, quo minus perficiat quod cupit, impeditio, mora, obstaculum. saepissime de sarcinis exercitūs, qua significatione pluralis numerus usurpatur, et impedimentorum nomine veniunt etiam calones et iumenta.

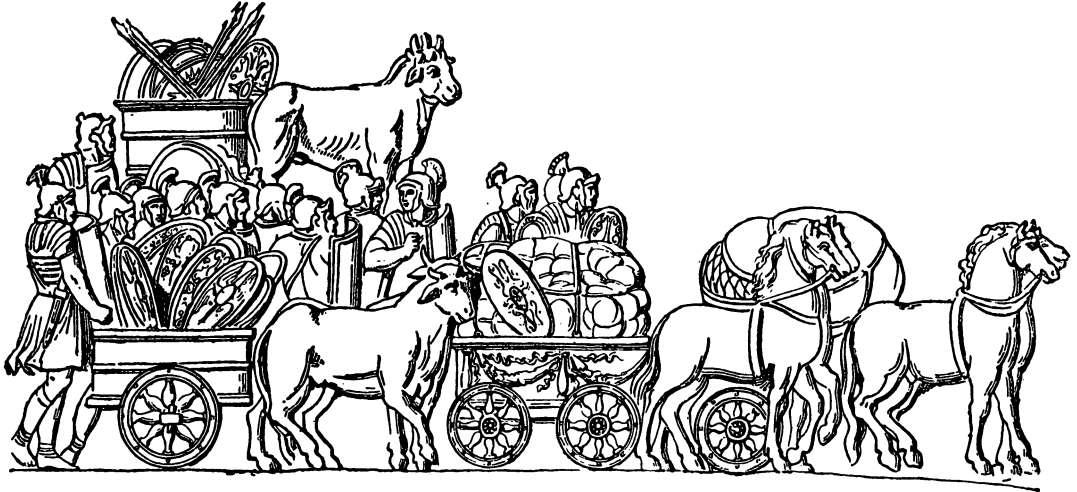

Caesar, B. G. 1, 26:

„alteri se in montem receperunt, alteri ad impedimenta et carros suos se contulerunt.“
imago e columna Traiana, impedimenta cum carris et iumentis (equis et bubus) sarcinis onustis.

incunabula –orum, n. pl.

a) ea, quae cunis insunt, quae ad cunas muniendas et ornandas pertinent, id est lectulus et fasciae lineae lanaeque, quibus infantes involvuntur.

b) sumitur pro loco, ubi nati sumus.

c) etiam pro „principio“ et „origine“ sumitur.

Cicero, de orat. 1, 6, 23:

„ab incunabulis nostrae veteris doctrinae ...“

*incunabula nominantur prima opera arte impressoriā in lucem edita (inter annos circiter 1450–1520).

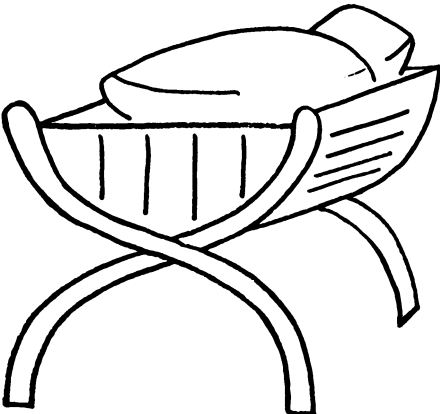

cuna

incus –udis, f.

incus est instrumentum ex solido ferro, super quod fabri ferri massas cudunt et formant.

Cicero, Nat. D. 1, 20, 54:

„formae ... quas vos effici posse sine follibus (follis) et incudibus non putatis.“

proverbium: „incudem eandem tundere“ = in eodem labore perseverare.

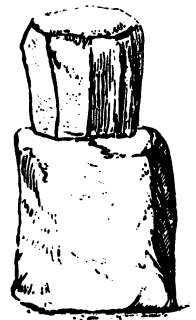

index —icis, m.

qui aliquid indicat, defert. digitus index est digitus, quo res indicamus.
in libris index est summa, seu elenchus, quo res, quae in iis continentur, summatim indicantur. ***in tabernis index ciborum cibos indicat, qui hodie offeruntur.

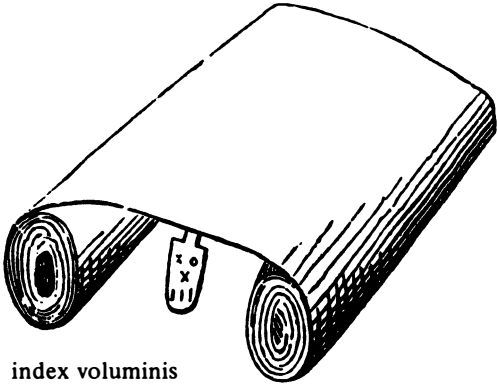

index voluminis

infula —ae, f.



vitta

infula sacerdotis

infula generatim est quaelibet fascia. speciatim ac saepius est ornamentum capitis sacerdotale.
Paulus Diaconus, p. 113, 1:

„infulae sunt filamenta lanæ, quibus sacerdotes et hostiae templeque velabantur.“

Servius, ad Aen. 10, 538:

„infula est fascia in modum diadematis, a qua vittae ab utraque parte dependent, quae plerumque tortilis, de albo et cocco.“

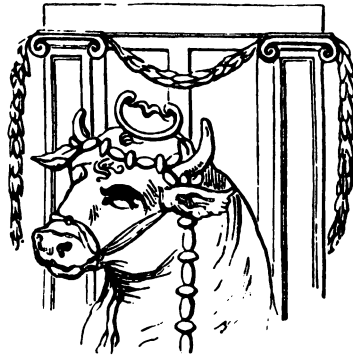

hostiae infula

**initialis (sc. littera)

est prima littera manuscripti, paginae aut capituli, quae minio (minium) delineatur et picturis ornatur.



insigne —is, n.

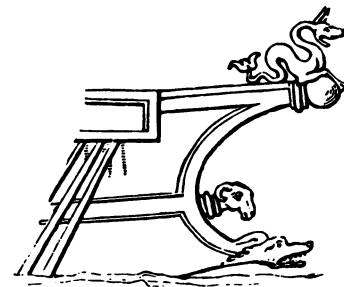

insigne navis

insignis est qui signo (*signum*) aliquo vel *notā* inter alia eminet.
 insigne, -is, n., est tabula vel imago vel signum, quo res notantur, exempli gratia *naves*, *tabernae* aliaque. etiam magistratūs insignibus quibusdam praediti erant, ut consules aut praetores lictoribus (*lictor*).

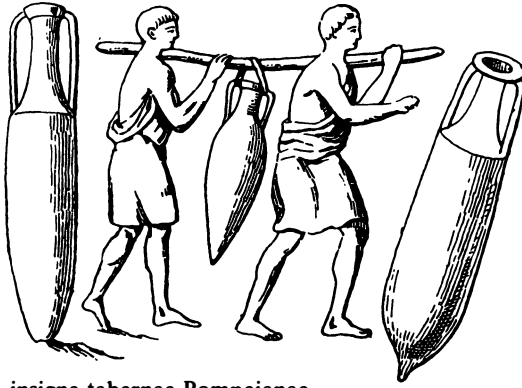

insigne tabernae Pompeianae

instrumenta musica

instrumenta musica sunt triplicis generis:
 a) alia, quae spiritu inflantur ut tibiae, fistulae, tubae, cornua, organa (hydraulica).
 b) alia, quae nervis intenduntur ut lyra, cithara et alia.
 c) alia, quae manu pulsantur ut tympana, sistra, cymbala etc.

tuba organum hydraulicum cornu

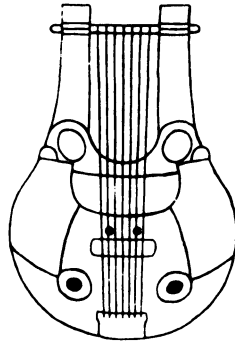

cithara, -ae, f.

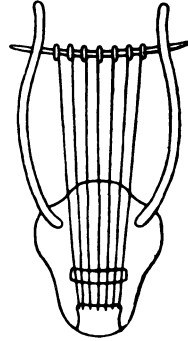

lyra, -ae, f.

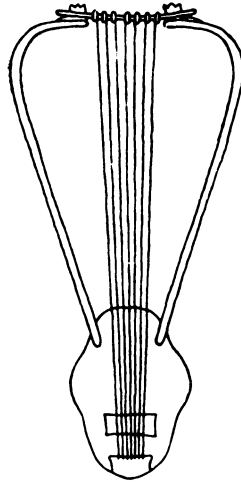

barbitum, -i, n.

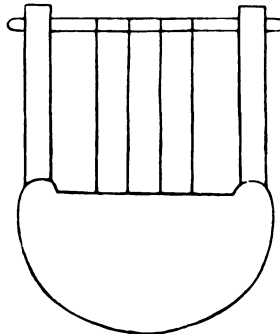

phorminx, -ingis, f.

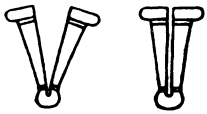

crotala, -orum, n.

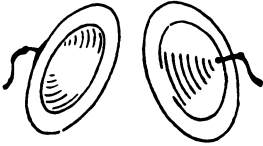

cymbala, -orum, n.

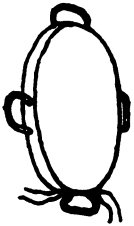

tympanum, -i, n.

instrumenta scribendi

stilus tabula volumen epistolae
sigillo signatum et
inscriptione praeditum

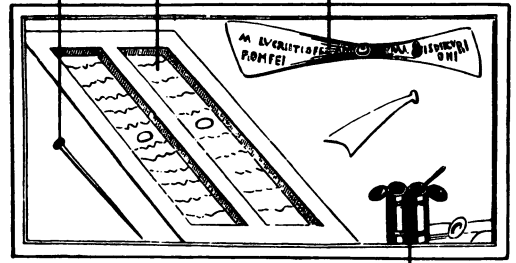

atramentarium cum calamo et atramento.
imago in domo Lucretii, Pompeiis inventa

insula -ae, f.

- a) est terra in medio mari, undique aquis cincta.
b) latiore sensu est terra seu locus flumine aut lacu clausus.
c) a similitudine insulae dicuntur domus urbanae, quae non iunguntur communibus parietibus cum vicinis, circuituque publico aut privato cinguntur. insulae plura cenacula et cubicula habebant, quae pluribus familiis locabantur et fere pauperiorum.

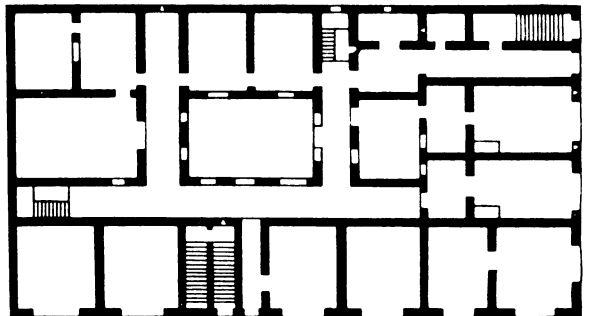

insula „Dianae“ quae dicitur, Ostiae sita, orthographia et ichnographia

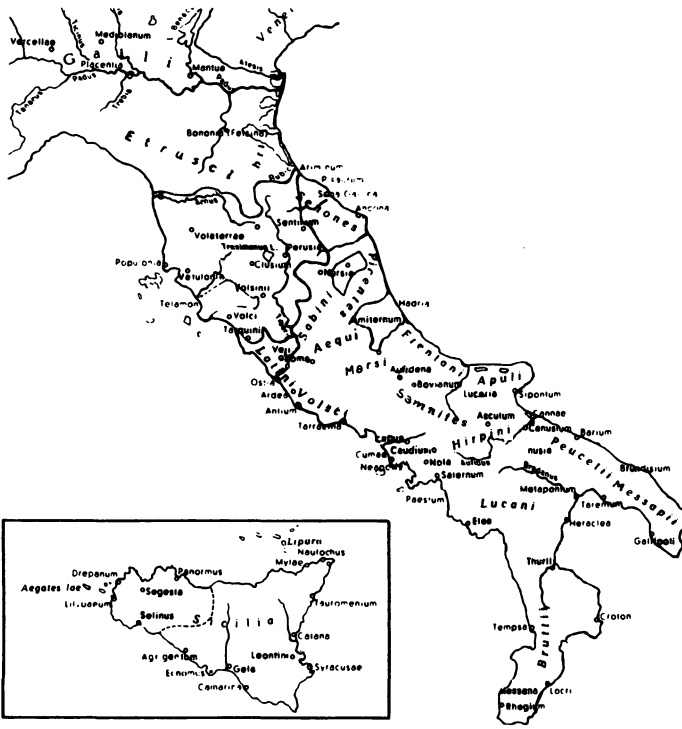

iugum -i, n.

est ligneum instrumentum recurvum, quod duorum boum (aut equorum) collo transversum impositum, eos simul iungit et colligat. in quadrigis (*quadriga*), ubi equi quaterni aequa fronte iuncti erant, duo medii iugum

habebant, duo reliqui funibus (*funis*) ac loris alligabantur. hinc illi *iugales*, hi *funales* dicti. saepe hostes victi a Romanis sub iugum missi sunt; quod erant *hastae* in modum iugi iunctae.

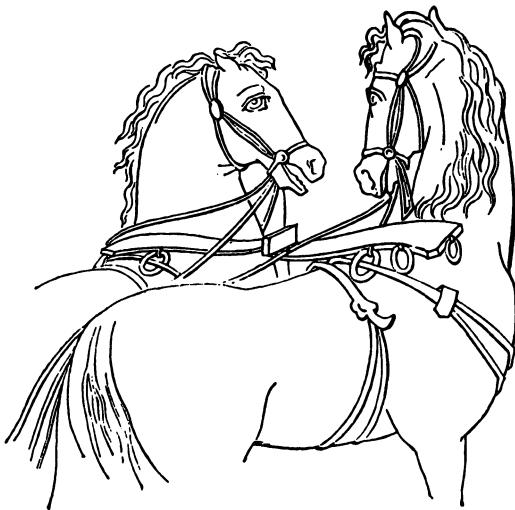

equi iugales

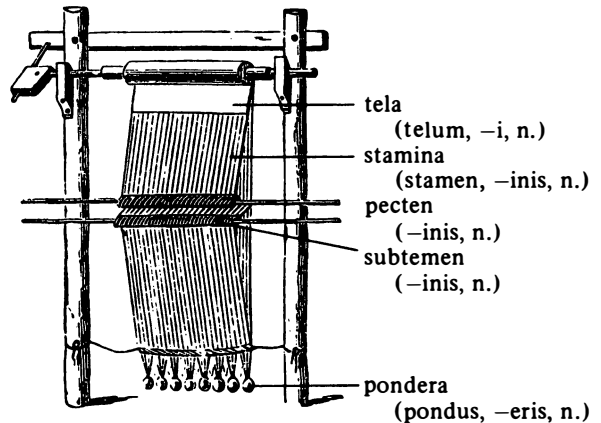

iugum textorium

labarum –i, n.

est *vexillum* militare auro intextum, gemmisque (*gemma*) intermicantibus splendidissimum, quod imperatori praeferi atque a militibus paene adorari solebat. Constantinus imperator labaro coronam (*corona*) imposuit cum cruce et litteris initialibus (*initiale*) nominis Christi X P hoc modo:

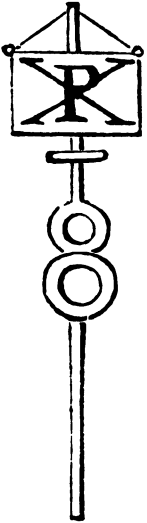

labrum –i, n.

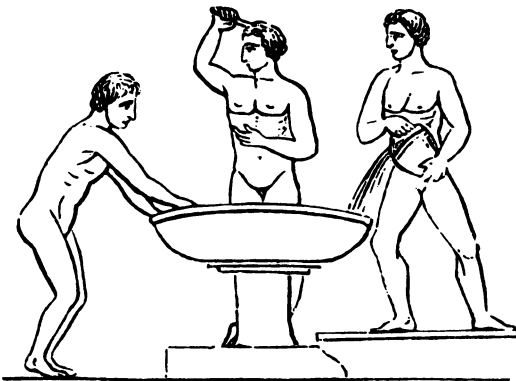

est vas grande latique oris, diductas habens oras et in exteriorem partem, in modum labrorum repandas, unde se balneatores aquā frigidā

aspergebant, ut in imagine monstratur: aquarius aquam labro infundit, balneator se strigili radit. (*strigilis*)

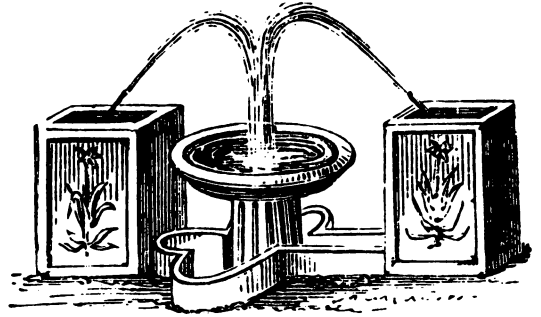

labrum siphone (sipho) munitum

labyrinthus –i, m.

est locus multis viarum ambagibus inflexus, ex parietibus vel ex arboribus. omnium celeberrimus erat labyrinthus Creticus, perplexis parietibus (*paries*), factus a Daedalo (*Daedalus*) iussu regis Minois, in quo Minotaurus monstrum biforme inclusum erat. itinerum ambagibus, occursibus et recursibus difficillimus labyrinthus omnium erat.



nummus (drachme) Creticus, in fronte Minotaurum, a tergo labyrinthum monstrans

lacerta –ae, f.

est serpens quadrupes satis nota; e genere reptilium: lacerta agilis, lacerta vivipara. in terris Mari Mediterraneo adjacentibus genus lacertae est, quod Tarentola Mauretanicus vocatur. haec lacerta pedibus suis parietibus tectisque adhaerere potest.

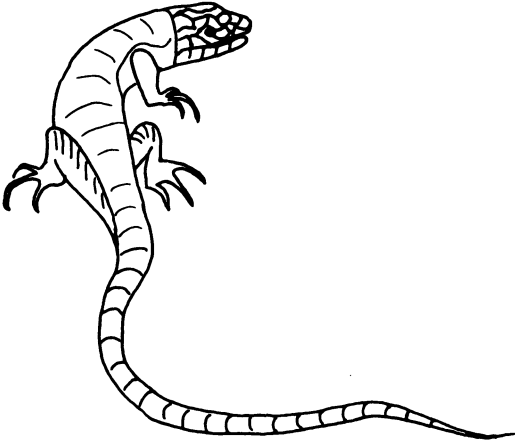

lanx –cis, f.

a) lanx est vas escarium latum et cavum ex aliquo nobiliore metallo plerumque factum, in quo cibi reponuntur et mensae inferuntur.



b) a similitudine lances sunt in libra duo illa vascula, in quorum altero pondus, in altero res ponderanda imponitur; unde bilanx dicta.

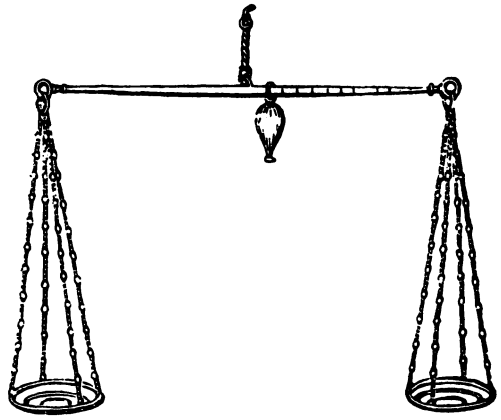

libra bilanx

lapidarius –i, m.

a) ad lapides pertinet.

b) (faber) lapidarius, qui lapides findit aut sculpsit (*artificia*). in lapicidina vel latomia lapidarius officium suum exercet.



laquear –aris, n. (aut lacunar, –aris n.)

est interstitium tignorum in caelo conclavis, ex eo dictum, quia inter tignum et tignum veluti lacuna est: item ipsum caelum seu tabulatum, sive contignatione constet, sive tabulis suffixis, et inter plana intervalla cavitates sive lacūs habentibus, sive etiam aequato opere coagmentatis. Hae laquearia picturis aliisque ornamentis ornari solebant.

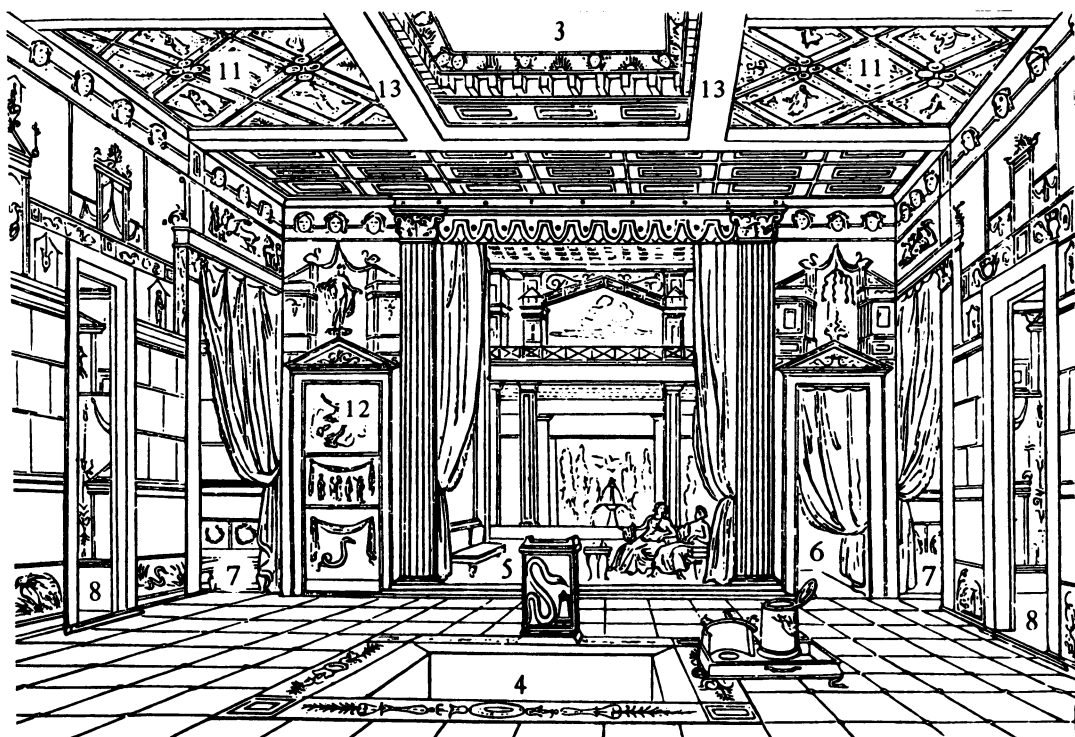

domus Pompeiana (reconstructa)

- 1 vestibulum
- 2 atrium
- 3 compluvium
- 4 impluvium
- 5 tablinum
- 6 triclinium
- 7 alae
- 8 cubicula
- 9 tabernae
- 10 hortus
- 11 laquearia in tecto aut caelo conclavium
- 12 aedicula
- 13 tignum

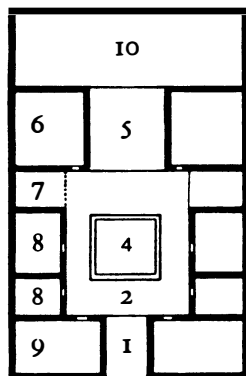

ichnographia
eiusdem
domūs

laqueus –i, m.

a) laqueus est vinculum ita nexum, ut pondere magis claudatur.

Cicero, Verr. 4, 17, 37:

„homini iam collum in laqueum inserenti subvenisti.“

b) laqueus est fraus, insidiae:

Ovidius, Ars. Am. 3, 591:

„dum cadit in laqueos captus ... amator“

Quintilianus, 5, 10, 101:

„in laqueos inexplicabiles incidere.“

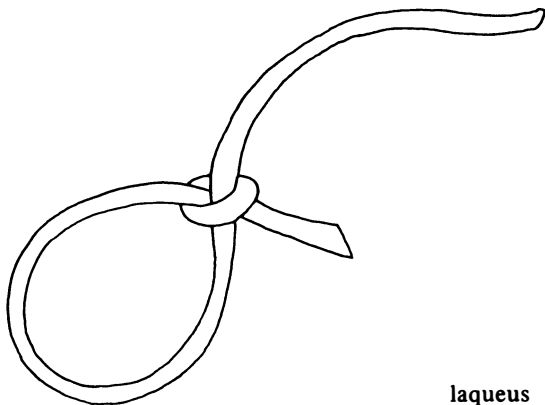

laqueus

later -eris, m.

later est terra in variam formam durata, sive igni percocta sit, sive non, in usum aedificandi; deminutivus: laterculus (eadem significatione).

Varro, R. R. 1, 14, 4:

„saepimentum ... quod e lateribus coctilibus, ut in agro Gallico, quod e lateribus crudis, ut in agro Sabino.“

modus dicendi: lateres coquere.

proverbium: „laterem lavare“ = rem inutilem facere.

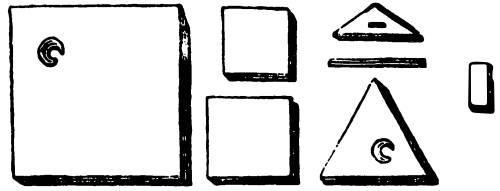

laterna -ae, f.

est instrumentum ex laminis corneis, vel ex alia materia, in quo candela accensa, vel ignis oleo ardens includitur, ne a vento extinguatur. nocte

laternis via illustrabatur, ut apud Plautum, Amphitr. 148:

„Servus Sosia a portu illic nunc cum laterna advenit.“

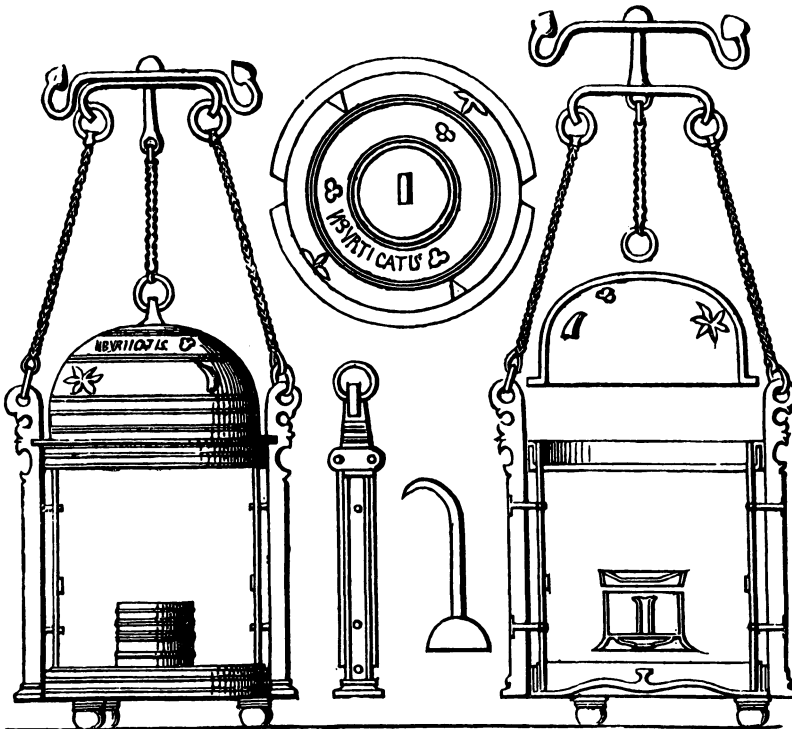

laternae Pompeianae

latifundium -i, n.

latus fundus, ampla possessio agri.

Plinius, H. N. 18, 6, 7:

„verum confitentibus, latifundia perdidere Italiam, iam vero et provincias.“

a mathematicis superficies dicitur, quae extremitas a Cicerone, magnitudo longa et lata.

Macrobius, in somn. Scip. 2, 2, 4 ss:

„punctum corpus (est) individuum ... hoc protractum efficit lineam, ... hanc lineam si geminaveris, alterum mathematicum corpus efficies, quod duabus dimensionibus aestimatur, longo latoque, sed alto caret: et hoc est, quod apud illos superficies vocatur.“

supplicatio –onis, f.

a) supplicatio est supplicandi actus, precatio in universum. (vide imaginem supplicis!)

b) ponitur pro dei adoratione et gratiarum actione pro re aliqua, quae rei publicae prospere evenit. apud Romanos supplicationes dicebantur, quando, re feliciter actā, ex senatus consulto *templa* aperiiebantur divorumque simulacra in lectulis collocabantur sacra faciente pontifice et populo certatim ad pulvinaria confluyente disisque suis pro eorum in rem publicam meritis supplicante gratiasque agente. (*lectisternium*) Cicero, Prov. cons. 11, 27:

„decem dierum supplicatio decreta Cn. Pompeio.“



supplex

sutor –oris, m.

est is, qui calceos suit (suo, sui, suere), (*vestimenta*).

proverbium: „sutor, ne supra crepidam“, quo monemur, ne, quibus in rebus minus intellegimus, in his sententiam proferamus.

sutrina –ae, f.

est officina sutoris.

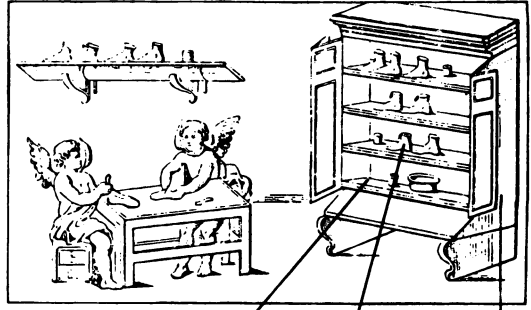

pluteus calceus, armarium
crepida

in hac imagine Herculani depicta, videmus sutrinam; sutores sunt duo genii alati. in armario calcei (aut crepidae) impositi sunt pluteis.

symbolum / symbolus

a) est *signum, nota*, indicium, ex quo quid cognosci potest.

b) est etiam anulus, quo utebantur Romani ad epistulas et vasa obsignanda et in pignus atque argumentum cuiuspiam rei promissae.



anulus symbolo
instructus

c) est item *imago* ipsa anulo impressa.

Plautus, Pseudolus 55–58:

„ea causa miles hic reliquit symbolum, expressam in cera ex anulo suam imaginem, ut qui huc afferret eius similem symbolum cum eo simul me mitteret.“

d) apud ecclesiasticos scriptores symbolum est regula seu formula eorum, quae credenda sunt ex fide divina, qua fideles ab infidelibus discernuntur.

sufflamen –inis, n.

est lignum illud vel vinculum, quo per radios rotarum (*rota*) traiecto, vel potius ferreum instrumentum, quo subter rotae unius canthum (*canthus*) supposito, currūs in declivibus locis nimio impetu ruentes cohibentur.

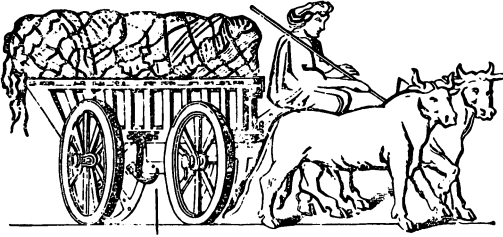

sufflamen

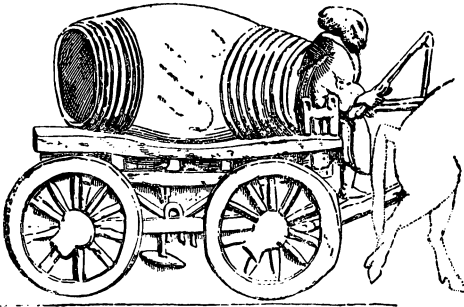

in prima imagine in villa rustica Helvetica prope Urbam inventā pendet de rhaeda sufflamen ante posteriorem rotam

sulcus –i, m.

sulcus est vestigium aratri (*aratrum*), fossula in longum vomere impresso ducta.

formulae: sulcos ducere, sulcos agere.

Festus, p. 302, 4 M.:

„sulci appellantur, qua aratrum ducitur vel sationis faciendae causā vel urbis condendae.“

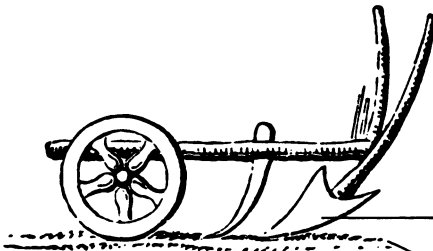

vomer

sulcus

suovetaurilia –ium, n. pl.

sunt sacrificium suis, ovis et tauri, quod usurpabatur in lustrationibus agrorum, populi, exercitus et huiusmodi.



nostra imago suovetaurilia in lustratione exercitūs habita monstrat. dextrā est sus (1), sinistrā aries (ovis) (2) et taurus (3). imperator (4) tus in flammās coniicit. legionarii adstantes *signa* militaria (5) et *vexilla* (6) portant, duo tubā (7) canunt

superficies –ei, f.

est pars superior vel summa alicuius rei aut quidquid super faciem alicuius rei est vel fit vel exstat.

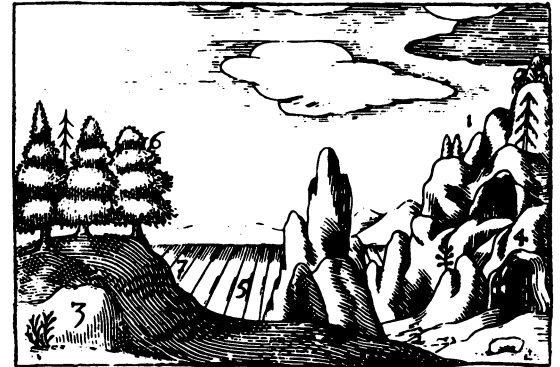

Comenius has partes superficies terrae distinguit: montes (1), valles (2), colles (3), speluncae (4), campi (5), silvae (6); quibus adiungi potest clivus (7).

sublica –ae, f.

est trabs praelonga, humi statuta et erecta ad quippiam sustinendum, pertica, palus. speciatim dicitur de trabibus, quae in alveo fluminis defixae pontem sustinent ut in hoc

ponte in Rheno a Caesare facto aut ut in primo ponte Romae in Tiberi facto, qui ideo pons sublicius nominabatur. (*pons*)

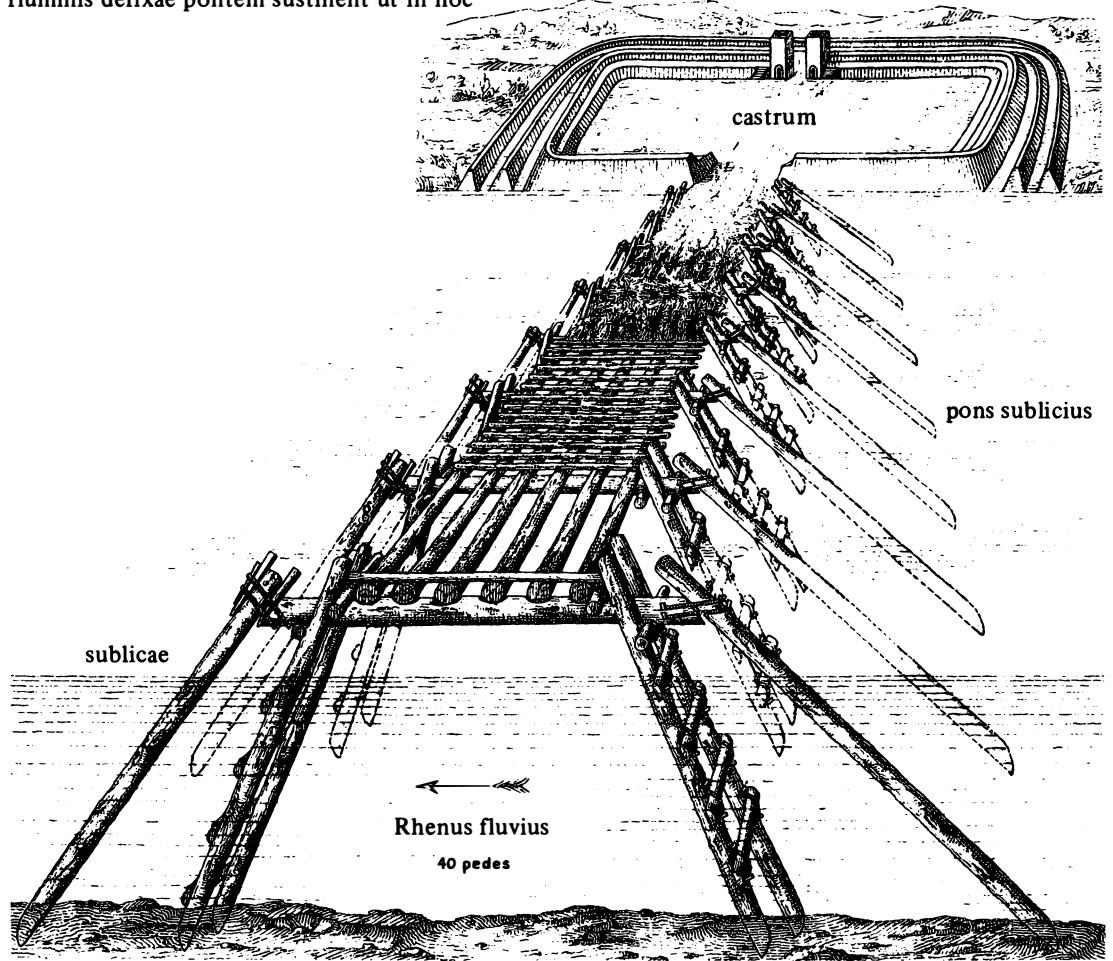

suburbium –i, n.

suburbium sunt frequentes extra urbem domus instar vici urbani aedificatae.

adi. suburbanus, –a, –um = sub urbe positus, urbi vicinus.

Cornelius Nepos, Att. 14, 3, de Attico, Ciceronis amico:

„nullos habuit hortos, nullam suburbanam aut maritimam sumptuosam villam, neque in Italia, praeter Arretinum et Nomentanum, rusticum praedium.“

Suburbana Italia est ea pars Italiae, quae vicina est Romae.

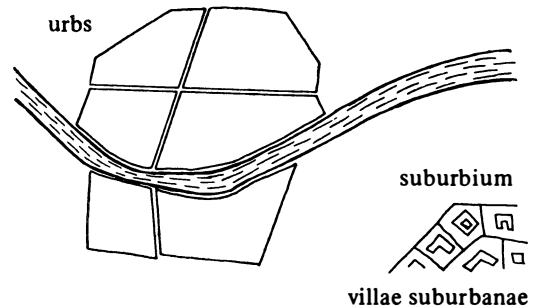

statēra –ae, f.

est instrumentum, quo res sine lancibus ponderatur.

statera differt autem a trutina, ut species a genere. duae enim species trutinæ sunt:

- a) libra, quae binas habet lances;
- b) statera, quae scapo constat punctis distincto, quae pondera discriminant.

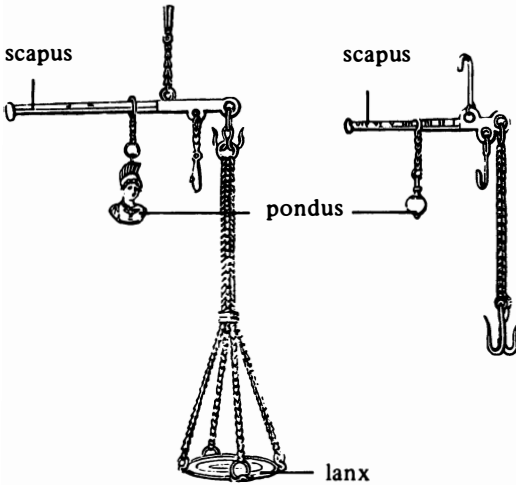

statua –ae, f.

id quod statuitur, quod erectum stat arte elaboratum, speciatim est *signum*, simulacrum, ex aere aliove metallo, e lapide aut ligno, imaginem (*imago*) referens cuiuspiam, honoris et memoriae causā, vel columella, *pīla*.



statua Atlantis umeris aedificium sustentis

stillicidium –i, n.

a) stillicidium est umor stillatim cadens et ipse casus umoris stillatim cadentis. saepe dicitur de casu aquae pluviae ex tectis vel ex proiecturis tectorum stillatim defluentis.

b) stillicidia dicuntur etiam loci in tectis, e quibus aqua pluviae stillatim decedit. (*tegula*)

strenae –arum, f. pl.

strena dictum est munus, quod dabatur die festo et fere anni initio, boni omnis gratiā. (strenae = francogallice „les étrennes“)



in *lucernā* fictili Victoria votum in annum novum apportat cum strenis. *Ianus* biceps in nummo mensem Ianuarium, initium anni, significat



nummus Commodo imperatori dedicatus. in margine haec leguntur: „Felici imperatori Annum novum faustum felicem“ (ominor). strenae sunt fructūs, nummi (1) marcupium (2) plenum aliaque

strigilis –is, f.

strigilis est instrumentum serratum (*tignarius*), curvum, manubrio et canaliculo instructum, quo utebantur praecipue in balneis (*balneum*) ad destringendam cutem, abradendas sordes et sudorem detergendum. (*spongia*)

stabulum –i, n.

est statio, sedes, habitatio, locus, et saepe est locus, ubi iumenta et pecora aliaeque bestiae degunt.

equile, –is, n. est stabulum equorum, bovile stabulum boum.

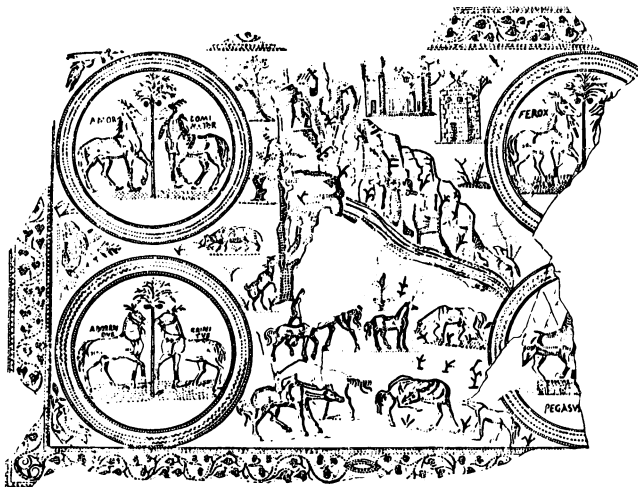
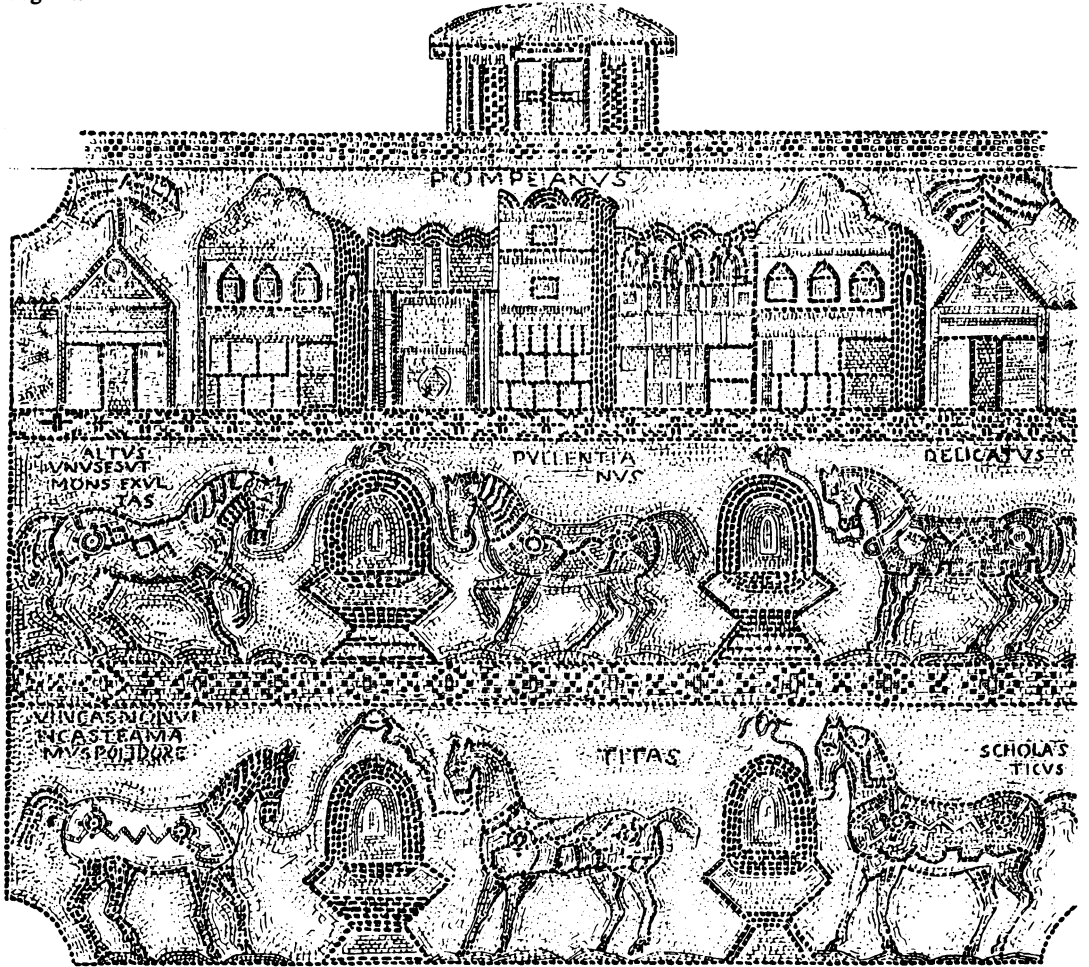

hae duo opera tessellata Africae Septentrionalis e villis rusticis Romanis. primum stabulum equorum (equile) monstrat. equi ante *patenas* (*praesepia*) stant; nomina eorum indicantur, ut etiam in secunda imagine, ubi stabulum et cohors equorum depicta sunt.

sponda –ae, f.

est exterior lecti (*lectus*) aut grabati tabula aut tiggillum, cui adnectuntur restes, quibus culcita sustinetur.

culcita est id, super quod dormientes quiescimus, non id, quo integimur.

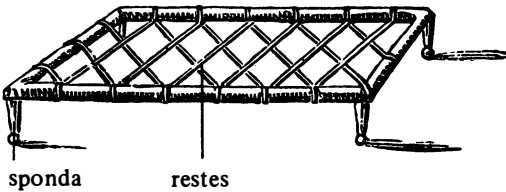

spongia –ae, f.

spongia est molle corpus, rarum et fistulosum, medium inter animal et plantam, et utriusque naturae particeps. nascitur in marinis petris aliturque conchis, pisce, limo. varius est spongiarum usus: usurpantur tergendis mensis et pavimentis, exhauriendis siccandisque liquoribus; imbibunt enim facile, nec reddunt nisi comprimantur.

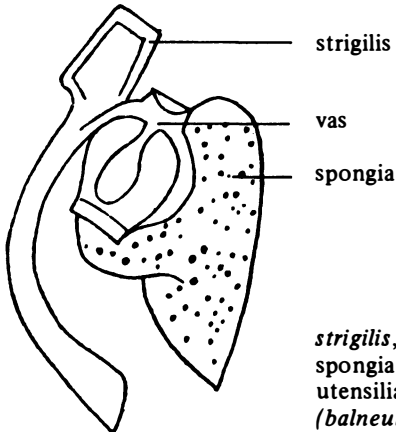

sponsus, sponsa

ptc. verbi spondeo, sponondi, sponsum. verbum usum habet in contractibus, pactis, sponsionibus, stipulationibus, cum quis se daturum quippiam aut facturum pollicetur vel pro altero se obligat.



sponsa, –ae, f.

est mulier alicui promissa in matrimonium, pacta, sperata et nondum uxor.

sponsus, –i, m.

est qui desponsus est, nondum maritus.

sponsalia, –ium, n. pl.

apud Latinos per stipulationem contrahebantur, id est per interrogationem et promissionem factas inter eum, qui daturus erat aliquam mulierem in uxorem, et inter eum, qui accepturus. in his sponsalibus statuebatur etiam dos, die matrimonii aut tribus pensionibus solvenda.

sporta –ae, f.

sporta est vas, *corbis* simile, e vimine aut iunco aut sparto aliave levioere materia, ad varios usus.

deminutivus: sportula, sportella.

Martialis, 10, 37, 17:

„dum loquor, ecce redit sportā piscator inani.“
sportulae etiam sunt nummorum receptacula.

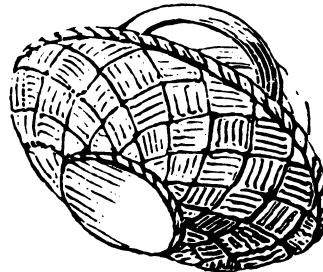

speculum –i, n.

est instrumentum ex vitro, chalybe, argento, stanno et similibus, in quo imaginem nostram videmus:

translate: Hieronymus, Ep. ad Fur. 13:

„speculum mentis est facies, et taciti oculi mentis fatentur arcana.“

Paulus, ad Cor. 1, 13, 12:

„videmus nunc per speculum in aenigmate; tunc autem facie ad faciem.“

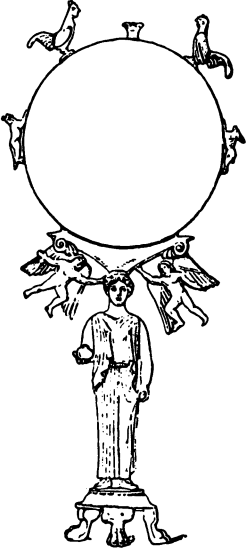

speculum Etruscum
e stanno factum

sphaeristerium –i, n.

est locus pilae lusui destinatus, a Gr. sphairizo = pilā ludo. erant sphaeristeria cubicula in balneis (*balneum*), in quibus se tum aliis rebus, tum pilae (*pila*) ludo exercebant.

titulus Aventici inventus:

TI. CLAUDIUS TI. FIL(IUS) / MATERNUS
AEDILIS SPHAERISTERIUM D(E) S(UO)
D(EDIT)

spica –ae, f.

est acies, cacumen; sed speciatim occurrit et est collectio plurium granorum in summo culmo frumenti, hordei et huiusmodi.

Varro, r. r. 48, 1:

„spica ea, quae mutilata non est, in hordeo et tritico tria habet continentia, granum, glumam, aristam: et etiam primitus spica cum oritur, vaginam.“

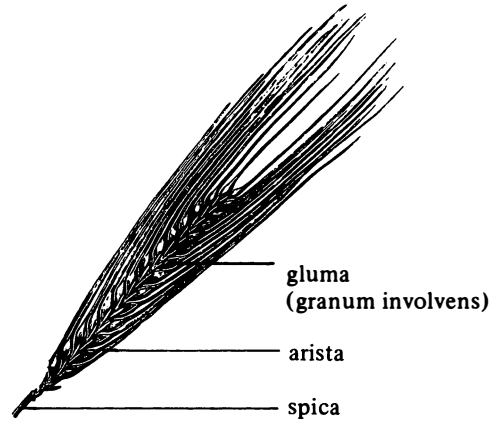

gluma
(granum involvens)

arista

spica

spina –ae, f.

spina generatim est id, quod acutum est, aculeus.

a) in re anatomica spina est vertebrarum series in dorso animalium, a collo ad extremum usque os (*os, ossis*).

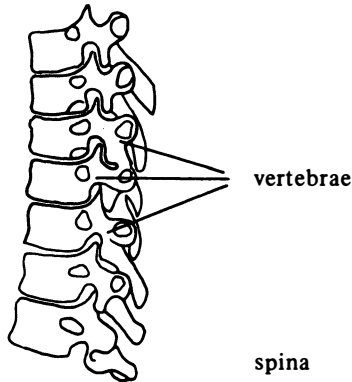

vertebrae

spina

b) spina etiam nominatur medius circi (*circus*) tractus, ubi *obelisci*, simulacra deorum et alia huiusmodi erant.

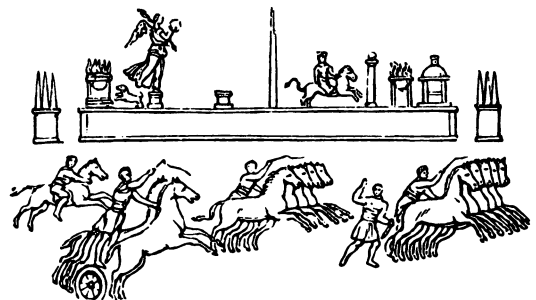

solium –i, n.

a) est sella regalis, thronus; sella deorum.

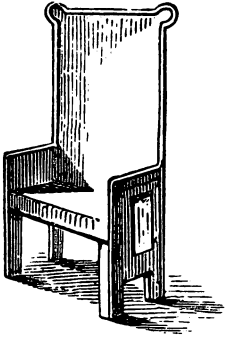

Servius, ad Aen. 1, 506:

„solium proprie est armarium uno ligno factum, in quo reges sedebant propter tutelam corporis sui ...“

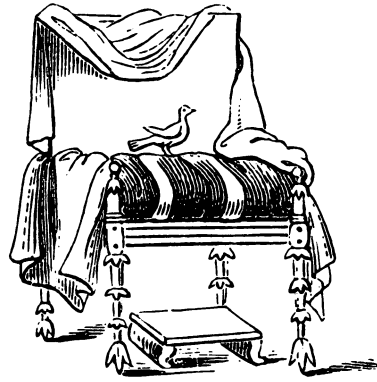

Vergilius, Aen. 10, 116:

„solio tum Iuppiter aureo
surgit ...“

b) solium etiam dicitur de sella concava, labro (labrum), alveo in balineis (balneum).

solstitium –i, n.

est tempus illud, quo sol stare videtur aliquantisper, tum quando signum Cancri ingreditur Iunio mense, tum quando signum Capricorni mense Decembri: illud est solstitium aestivum, quo sol incipit a nobis recedere, hoc solstitium hibernum, quo ad nos accedere. solstitium hibernum etiam bruma (= brevissima sc. dies) nominatur (zodiacus).

aequinoctium, –i, n.

est tempus illud, quo dies et noctes horarum spatio aequales sunt. Duo autem sunt aequinoctia: aequinoctium vernum, circa VIII. Ca-

lendas Apriles et in signo Arietis conficitur; autumnale X. Calendas Octobres in signo Librae.

Varro, L. L. 6, 8:

„cum (sol) venit in medium spatium inter brumam et solstitium, quod dies aequus fit ac nox, aequinoctium dictum.“

Columella, r. r. 11, 2, 31:

cum ab aequinoctio verno in Cancrum sol meat, omnes dies maiores sunt noctibus suis; item ab autumnali aequinoctio usque ad brumam minores dies noctibus dilatatis.

cursus solis

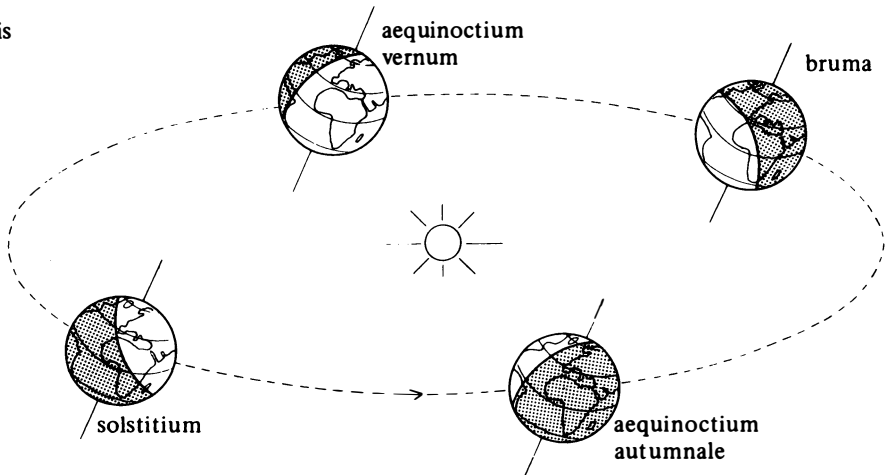

Plautus, Cas. 358/59:

„... adsunt quae imperavisti, omnia:
uxor, sortes, situla, atque egomet...“

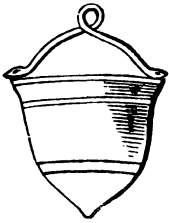

situla



sitella

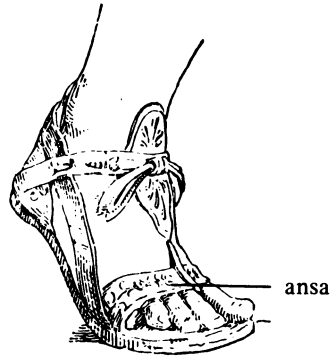

solea –ae, f.

est genus plani calceamenti, quo solum pedis tantummodo subtegitur, ansulis in superiore parte coeuntibus revinctum (*vestimenta*). communes erant soleae viris ac feminis, sed viri eisdem domi, foris calceis utebantur. soleatum enim prodire aliquem molle erat et indecorum et turpe.

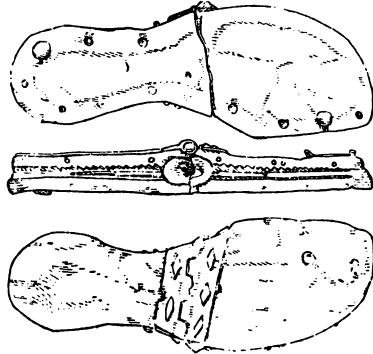

Lappones soleis oblongis in venationem prodeutes. imago sumpta ex opere Olai Magni, 1555 conscripto

sinus –us, m.

a) sinus dicitur de curvatura, flexu et cavitate cuiuscumque rei.

Columella, r. r. 4, 25, 1:

pars falcis (falx), quae flectitur, sinus nominatur.

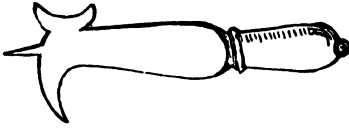

falx

b) de veste ampla eiusque plicaturis.

Livius, 21, 18:

„tum Romanus sinu e toga facto, hīc, inquit, vobis bellum et pacem portamus.“



c) sinus est in ora maris terra curvata ac recedens, et ipsae terrae circa sinum iacentes.

d) sinus in re mathematica: non nisi nomen commune habet cum prioribus usibus, nam ex erronea translatione vocis Arabicae provenit.

Sirenes Sirenum, f. pl., vel Sirenae –arum

Sirenes sunt maris monstra superiore parte virginis alatae formam habentia, inferiorem volucris.

navigantibus cantu Sirenum deceptis naufragium paratur.

tres Sirenes fuisse dicuntur, Acheloi fluminis et Calliopes vel Terpsichores vel Melpomenes Musae filiae.

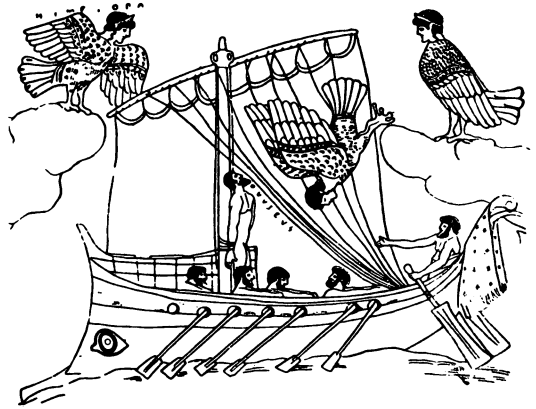

in imagine Ulixes mālo navis affixus cantum Sirenum auscultat, remigum autem aures cera obstructae sunt, ne ab eis decipiantur.

sistrum –i, n.

est *crepitaculum* aeneum, quo Aegyptii sacerdotes in Isidis sacris uti solebant.

sistrum apud Aegyptios vicem tubae (*instrumenta musica*) exhibebat.



sacerdos Isidis, dextrā sistrum agitans

situla –ae, f.

est vas ad aquam hauriendam, urna, hydria; inferior pars acuta est, ut melius in aquam putei (*puteus*) mergatur.

Anthologia Lat. 65. 3 M.:

„extractam puteo situlam cum ponit in horto.“
situla et deminutivum *sitella* dicitur urna, unde educuntur *sortes*: in situla aqua plena semper una sors summa est.

signum / sigillum, -i, n.

sigillum est imaguncula, parvum *signum* vel *statua*. sigillum etiam est imago, quae anulo signatorio in cera aliave materia imprimitur, ob-signandis litteris, amphoris (*amphora*), scriniis. verbum: sigillo l = signo vel sigillo instruere, munire.



anulus signatorius



signa militaria

silex -icis, m.

est lapis durus, sectilis, cui scintillae ignis excuduntur.

viae publicae silicibus stratae sunt, ut apud Livium, 41, 27, 7:

„clivum Capitolinum silice sternendum curaverunt.“

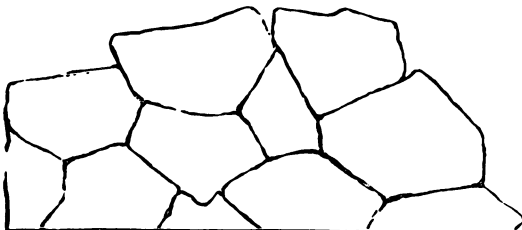

via silicibus strata

silicernium -i, n.

est cena funebris, quam alio nomine scriptores exsequium vocant.

proprie silicernium est convivium funebre (*funus*), quod senibus exhibetur.



silicernium in sepulcro Romano

simpulum -i, n.

est vas parvum, quo vinum in sacrificio libatur.



simpulum

cyathus

imago repraesentat sacerdotem, quae simpulo vinum ex amphora haurit.

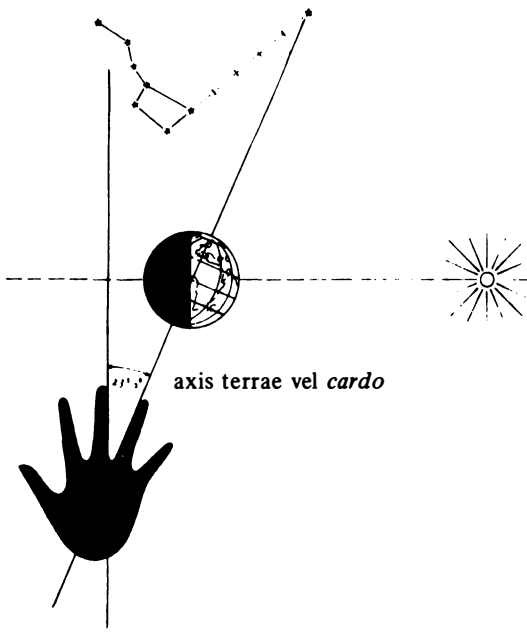

Septimontium –i, n.

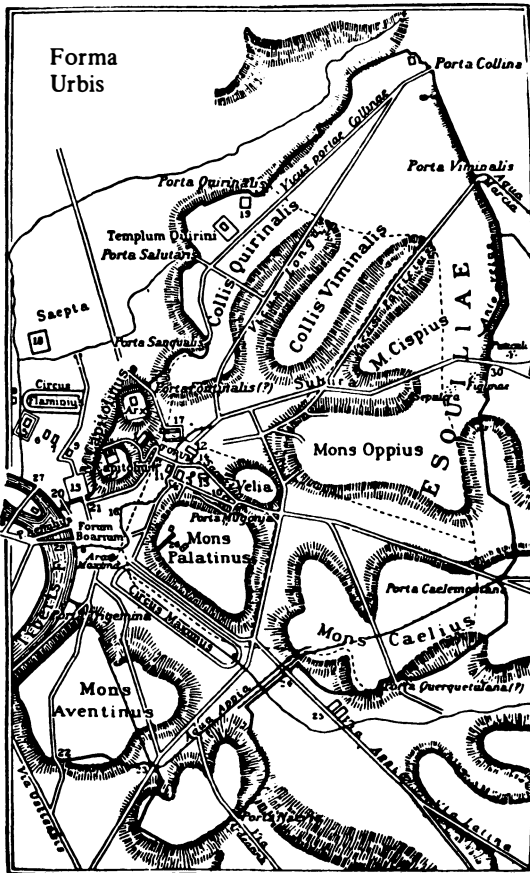

est dies festus, undecimo die mensis Decembris in honorem septem montium aut collium primitivae urbis Romanae celebratus. septem colles aut montes sunt:
 Mons Capitolinus (Capitolium)
 Mons Palatinus (Palatium)
 Mons Aventinus
 Mons Caelius
 Mons Esquilinus
 Collis Viminalis
 Collis Quirinalis.
 hi septem montes moenibus Servianis saepti erant (in Forma Urbis linea indicantur moenia Serviana).
 sunt alii colles et montes, ut Mons Vaticanus, Mons Marius trans Tiberim siti, qui non inter septem montes antiquae Urbis numerantur.

sera –ae, f.

sera est repagulum, fustis, qui opponitur clausis foribus.

Varro, L. L. 7, 108:

„serae, quibus remotis, fores panduntur.“

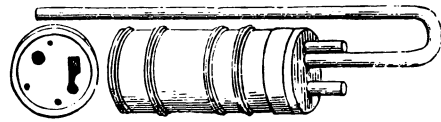

signifer –i, m.

signifer in re militari est is, qui in exercitu *signum* seu *vexillum* fert.



imago signiferi in columna Traiani

lius dictum est, consimile est), scopas, ut ita dicam, mihi videntur dissolvere.“
 „scopae solutae“ etiam de homine nihili dicitur.

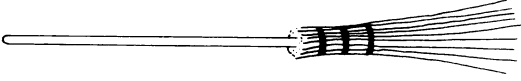

scytala –ae, f.

(Gr.) est genus epistolae secretioris apud Lacones (et postea etiam apud Romanos), quam scribebant in membrana, vel loro, super surculum spirae modo extento, deinde evolutum lorum mittebant ad eum, qui conscius erat: a quo rursus circa parem surculum circumvolvebatur, apparebantque verba prius descripta, quae parem surculum non habenti fieri nullo modo poterat, ut legerentur.

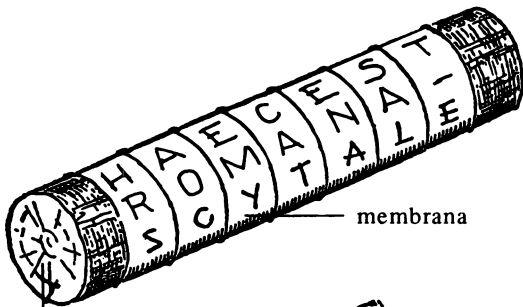

surculus

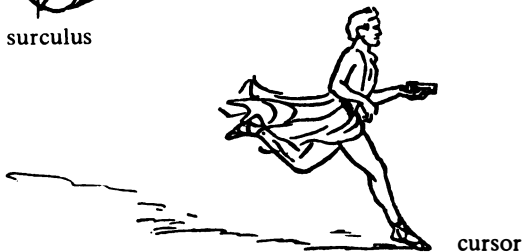

cursor

sella curulis

sella curulis fuit unum ex insignibus primo quidem regum Romanorum, deinde, eis exactis, maiorum magistratum solummodo, nempe consulum, praetorum, censorum et aedilium eorum, qui de patribus creati essent, quique hac ipsa de causa curules denominati sunt. sella curulis erat curvis pedibus, signis ornata, sublata gradibus, insculpta et distincta ebore.

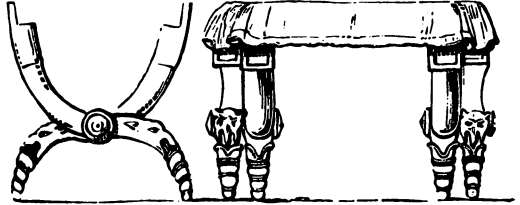

sensus –ūs, m.

sensus est actus sentiendi. sunt quinque sensūs in animalibus: auditus (–ūs, m.), visus (–ūs, m.), olfactus (–ūs, m.), gustus (–ūs, m.) et tactus (–ūs, m.).

„anima sapit ac meminit in cerebro, irascitur in corde, concupiscit in hepate, audit in auribus, cernit in oculis, olfacit in naribus, gustat in palato et lingua, sentit in omnibus partibus corporis.“ (Erasmus).

palatum, cerebrum: cf. –os, oris, n.

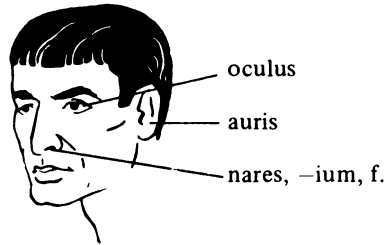

septentriones –um, m. pl.

sunt septem stellae, quae Ursam maiorem vel Arctum (–us, f.) conficiunt.

si recta linea a sexta ad septimam stellam quinque productur, invenitur stella polaris ad quam axis terrae vergit.

adiectiva: septentrionalis, –e, arcticus / antarcticus.

scamnum –i, n.

est gradus ligneus, qui lecto apponitur scandendi causā; aut fulciendorum pedum, dum sedēmus. deminutivum: scabellum.



scabellum

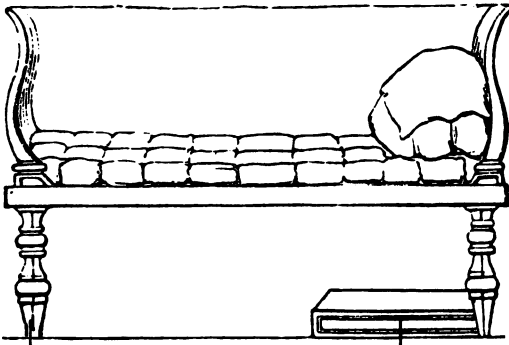

lectus

scamnum

scapha –ae, f.

scapha est exigua navicula, quales sunt, quae in maioribus circumvehuntur, vel eas pone sequuntur; item quibus utimur ad piscandum.



***scapha complicabilis, constat ex harundinibus et involucro impermeabili. harundines asportandi causā in parvas partes disiungi possunt.

sceptrum –i, n.

sceptrum baculum est, *signum* potestatis regum, ex ebone factum: sceptrum eburneum. sceptrum imperatoris *aquilā* ornatum est.



sceptrum Augusti



Porsennae, regis Etrusci, sceptrum

scopa –ae, f. (vel scopae –arum, f. pl.)

scopae ex multis virgis constant et sunt instrumentum quo verrimus et sordes cumulando purgamus.

proverbium: „scopas dissolvere“ = rem aliquam inutilem reddere.

Cicero, Orat. 71, 235:

„isti autem, cum dissolvunt orationem, in qua nec res, nec verbum ullum est, nisi abiectum, non clipeum, sed ut in proverbio est (etsi humi-

sarculum —i, n.

sarculum est instrumentum sariendis agris aptum. sarire = agros malis herbis purgare. rustici primum agros arabant et occabant, deinde sariabant et serebant.

Plautus, Capt. 663:

„semper occant prius quam sariunt rustici.“



sartago—inīs, f.

sartago est vas culinarium, in quo cibi fringuntur (frigo, frixi, frictum), vel aliud quippiam liquefit aut torretur.

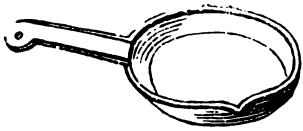

Saturnalia n. pl. (gen. —iorum), dat. abl. —ibus

Saturnalia erant festa septem dierum in honorem Saturni. celebrabantur mense Decembri. erant autem dies illi pleni laetitiae. his continuatae epulae et commissationes erant; munera ultro citroque mitti remittique solebant a Romanis. domini servis discumbentibus inserviebant; Saturni enim aevo omnia communia fuerunt, nec, quid servitus esset, notum fuit.

scala —ae, f. (scalae —arum, f. pl.)

est machina pluribus gradibus constans, qua utimur ad ascendendum in superiora.

Caesar, B. C. 1, 28, 4:

„milites positae scalis muros ascendunt.“
in aedibus plures erant gradus lignei vel lapidei

parietibus infixi atque immobiles, ad superiorem contignationem (*contignatio*) ferentes.

Martialis, 1, 117, 7:

„et scalis habito tribus, sed altis.“

h. e. in tertia aedium contignatione, ubi habitare solebant pauperiores.

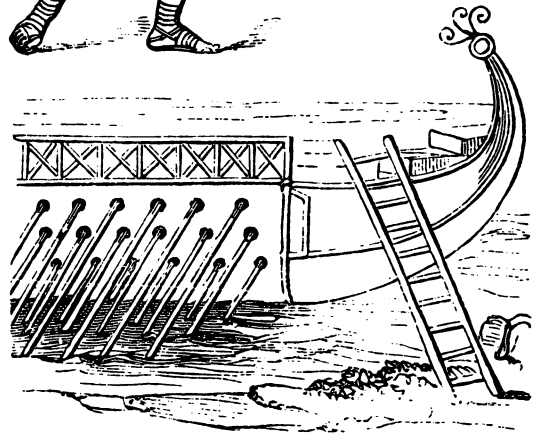

scala, qua navis adscenditur

scalprum —i, n.

est ferramentum, quo aliquid inciditur. varii hoc scalpro *artifices* utuntur, ut sutores, lapicidae, agricolae, chirurgi. deminutivum: scalpellum.

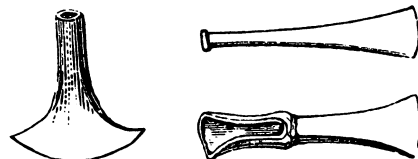

sarcina –ae, f. (vel sarcinae –arum, f. pl.)

sarcina est involuclum, fascis rerum utensilium, quem quis umeris portare potest. sarcinae a militibus in baculis portabantur.

Caesar, B. C. 3, 76:

„magna parte impedimentorum et sarcinarum relicta.“

formula dicendi: sarcinis gravare aliquem;

Phaedrus, 2, 7:

„muli gravati sarcinis ibant duo.“



miles sarcinam portans

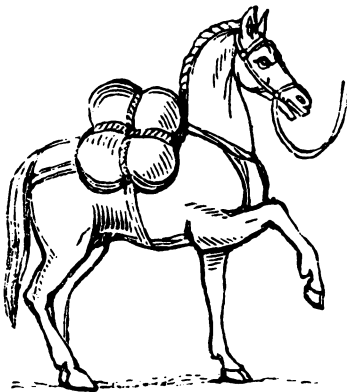

miles sarcinam portans

sarcophagus –i, m.

sarcophagus (Gr.), qui carnem comedit, consumit. speciatim dicitur de lapidis seu marmoris genere, in quo corpora defunctorum condita cito ad ossa rediguntur.

Plinius, H. N. 2, 96, 98 (211):

„At circa Asson Troiadis lapis nascitur, quo consumuntur omnia corpora: sarcophagus vocatur.“ sarcophagus pro sepulcro poni consuevit, praesertim eo, in quo cadaver integrum sine rogo (rogus) conditur.

parietes sarcophagorum saepe operibus caelatis ornabant, quae imagines nobis testimonio sunt earum opinionum, quas sibi homines de morte, de vita praeterita et futura finxerunt.

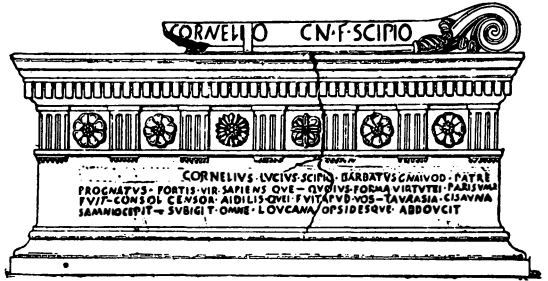

sarcophagus Scipionis Barbati

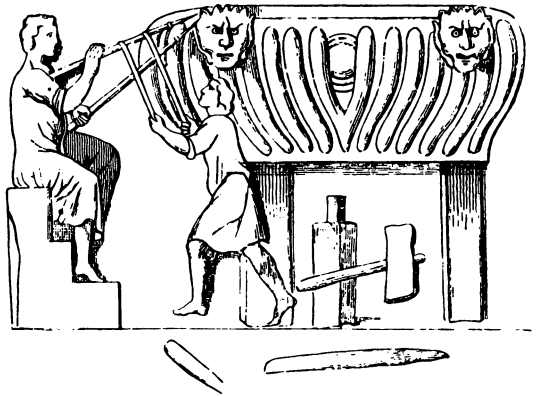

duo sculptores sarcophagum exculpunt

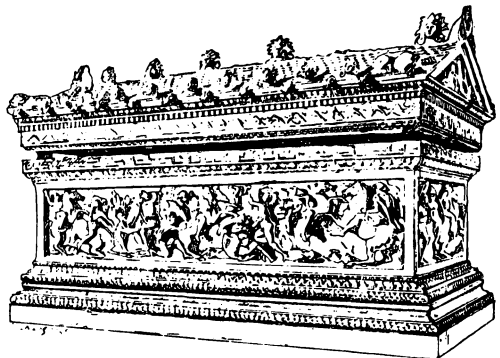

sarcophagus Alexandri Magni qui dicitur

saepes —is, f.

saepes est saeptum ex lignis, ramis arborum, aut spinis consitis, quo clauduntur agri aut horti.

Ovidius, Ars am. 3, 562:

„cingenda est altis / saepibus ista seges.“

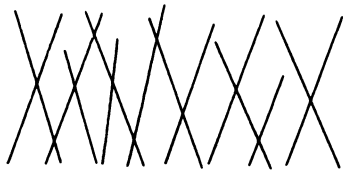

saepia —ae, f.

est genus marini piscis atrum humorem (quod atramentum dicitur) vomens, quo aquam circa

se adeo infuscat, ut ea se celet, et piscatoris mantis effugiat.

Ovidius, Halieut. 18 ss:

„saepia tarda fugae, tenui cum forte sub unda
deprensa est, iam iamque manus timet illa

rapaces,
inficiens aequor nigrum vomit illa cruorem,
avertitque vias, oculos frustrata sequentes.“



salmo —onis, m.

salmones sunt genus piscium, qui e montibus per vastissima flumina dulcium aquarum in mare descendunt, sub solari aestu autem a mari

per flumina in montes ascendunt agilitate saltus loca abrupta superantes.



salmones fumo siccantur (1), in aquā percoquantur (2), sole torrentur (3).

imago piscationem salmonum monstrat, qualis inter populos septentrionales perficitur.

sumpta est haec xylographia ex Olai Magni Historiā de Gentibus Septentrionalibus (1555)

earum rostris in victoriae monumentum, eam partem fori exornari placuit, ubi suggestus erat seu pulpitum, cuius figuram exhibet nummus G. Lolliae, quo contiones ad populum habebantur.

Cicero, in Pis. 3, 7:

„ita est a me consulatus peractus ... ut semper in rostris (sc. apud populum in contione) curiam, in senatu populum defenderim.“

rostrum –i, n.

a) est os, quo animalia (exempli gratia aves) cibum capiunt.

b) rostrum *navis* est trabs aenea aut ferrea, prominens ex prorae (*prora*) parte inferiore, rostri modo, unde, si navis remigio ageretur in hostilem navem, haec perforari poterat et deprimi.

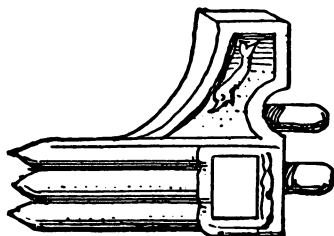

rostrum navale



prora navis cum rostro

rota –ae, f.

est instrumentum versatile, rotundum, *orbis*, quo circumacto currus procedit: eius partes sunt modiolus, radii, orbis (cantus).

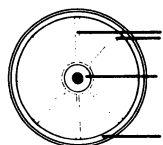

radii
modiolus, quo axis rotae continetur
orbis

rota tractoria in usu est ad onera magna sublevanda. rota machinae tractoriae calcantibus (*calco*) operarii versatur, oneraque in altitudinem tollit ut in imagine Capuae inventā, ubi columna erigitur hāc machinā.

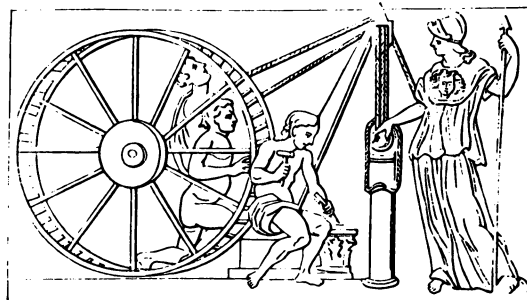

rota aquaria

Vitruvius, 10, 5, 1:

„(rotae) modioli aquam haurientes et in summum referentes, sine operariorum calcatura, ipsius fluminis impulsu versatae, praestant, quod opus est ad usum“ h. e. sine ope hominum qui calcando rotas versent. (*calco*)

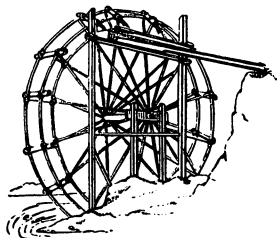

rota Fortunae

Fortuna dea in media rota sedet. in orbe (*orbis*) rotae homines circumvolvuntur: rex in solio sedet („regno“), fertur deorsum („regnavi“), in infimo est („sum sine regno“), denuo sursum fertur („regnabo“) (*quorsum*).

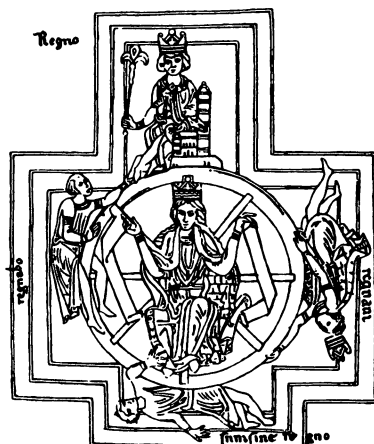

imago Fortunae sumpta est e manuscripto Medii Aevi, quod multa carmina popularia Latina continet et titulum „Carmina Burana“ portat.

rete —is, n.

rete est instrumentum, quo aves, ferae, pisces capiuntur; plaga, laqueus.

Cicero, Nat. Deor. 2, 48, 123:

„(araneolae) quasi rete texunt, ut, si quid inhaeserit, conficiant.“

verbum: irretire = reti involvere et capere aliquid.

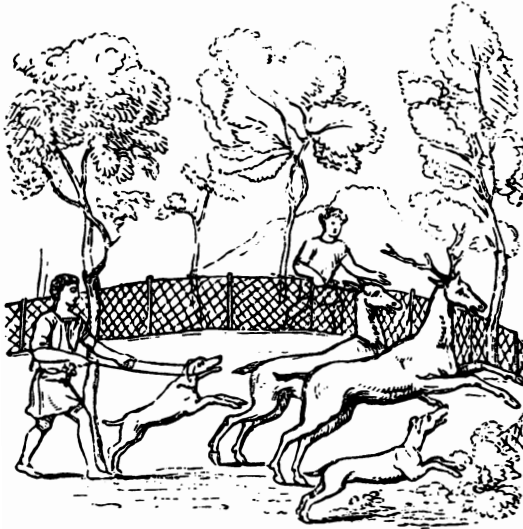

tela, vel rete, araneae

retiarius —i, m.

hoc nomine speciatim dicebatur alter ex gladiatoribus in arena depugnantibus: fuit enim genus gladiatorii certaminis, in quo duo pugnabant, quorum alter retiarius vocabatur, quod tunicatus fuscina et rete gestaret, quo adversarium involveret et implicaret.



fuscina

retiarius

reticulum —i, n.

generatim est parvum rete, vel rete solito angustioribus maculis contextum. reticulum nominatur etiam fascia vel pileolus (pileus) in modum retis a mulieribus praecipue usurpatus capillis continentis (vestimenta).

***reticulum hodie nominatur instrumentum reticulo instructum, quo pila in campum adversarii reicitur.

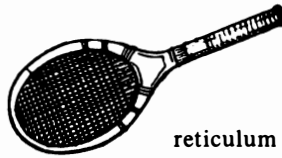

reticulum

rogus —i, m.

rogus est strues lignorum, in qua imposita cadavera cremabantur.



rostra —orum, n. pl.

est suggestus et locus circa positus, ante Curiam Hostiliam. quas enim primum hostiles naves Romani bello Latino ab Antiatribus ceperunt,



nummus M. Lollii Palicani, rostra in foro exhibens

raster —tri, m. vel rastrum —i, n.

raster est instrumentum rusticum dentatum, ferreum plerumque, interdum ligneum.

Plinius, N. H. 18, 20, 49:

„aratione per transversum iteratā, occatio sequitur, ubi res poscit, crate (*crates*) vel rastro.“



ratis —is, f.

ratis est connexarum trabium compages, quae per aquam agitur, usum navium praebens.

Paulus Diaconus, p. 272, 8 M.:

„rates vocantur tigna colligata, quae per aquam aguntur; quo vocabulo interdum etiam naves significantur.“

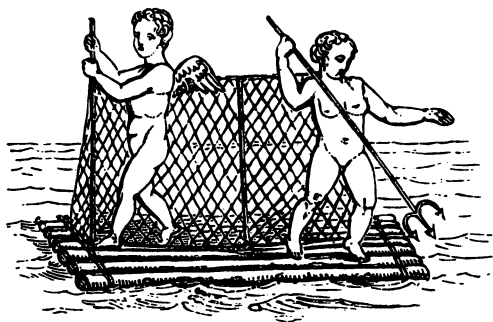

regio —onis, f.

regio est aliquoversum directio, orbita, linea.

Curtius, 8, 13, 23:

„traicere annem cum ceteris copiis in regionem insulae, de qua ante dictum est, parabat.“

caeli regiones quattuor sunt: septentrio, meridies, ortus, occasus (*regiones caeli*).

regio est etiam pars terrae magna aut parva, tractus, plaga, locus.

Cicero, Nat. Deor. 1, 10, 24:

„terrae maximas regiones inhabitabiles atque incultas videmus, quod pars earum appulsu solis exarserit, pars obriguerit nive pruinaque longinquo solis abscessu.“

in urbe est pars maior, quae in vicos rursus dividitur. urbs Roma in quattuor regiones dividebatur: Suburbanam, Esquilinam, Collinam et Palatinam.

*** hodie regio Basiliensis: partes Helvetiae, Franciae, Germaniae circum urbem Basileam sitas amplectitur, quae iisdem necessitatibus coniunctae sunt.

regiones dictae sunt etiam partes, in quas Italia divisa est, quaeque Augusto imperante undecim fuerunt.

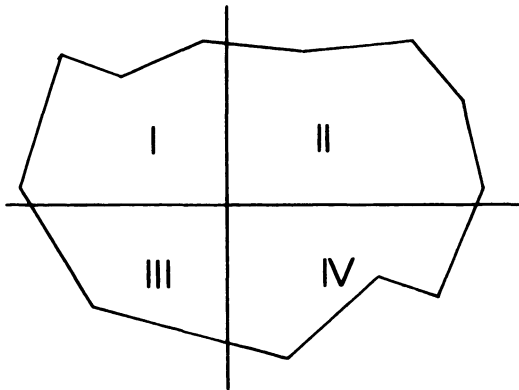

regiones caeli

et tempora

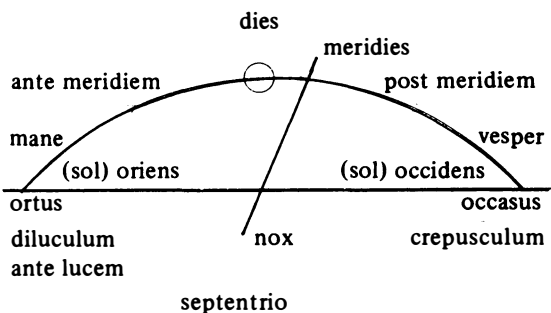

adiectiva:

ante lucem:	antelucanus
mane:	matutinus
ante meridiem:	antemeridianus
meridies:	meridianus
post meridiem:	postmeridianus
vesper:	vespertinus
dies:	diurnus
nox:	nocturnus
oriens:	orientalis
occidens:	occidentalis
septentrio:	septentrionalis

radius —i, m.

- a) est bacillus seu virga.
- b) speciatim est virga mensurum, mathematicorum, astronomorum, ad metiendum et figuras lineasque in pulvere delineandas.



radius astronomi

Cicero, Tusc. 5, 23, 64:

„humilem homunculum a pulvere et radio excitabo, ... Archimedem.“

- c) radius dicitur linea recta, quae a centro circuli ad circumferentiam ducitur.

- d) radii dicuntur regulae in rota, quae hinc modiololo, illinc cantho seu absidi inseruntur.

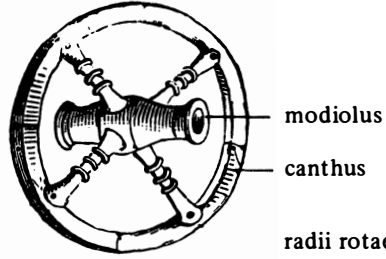

radii rotae

- e) a similitudine radius est splendor, qui e sole, stellis, igne emittitur.



radii coronae

Raetia, Noricum, Pannonia, Vallis Poenina

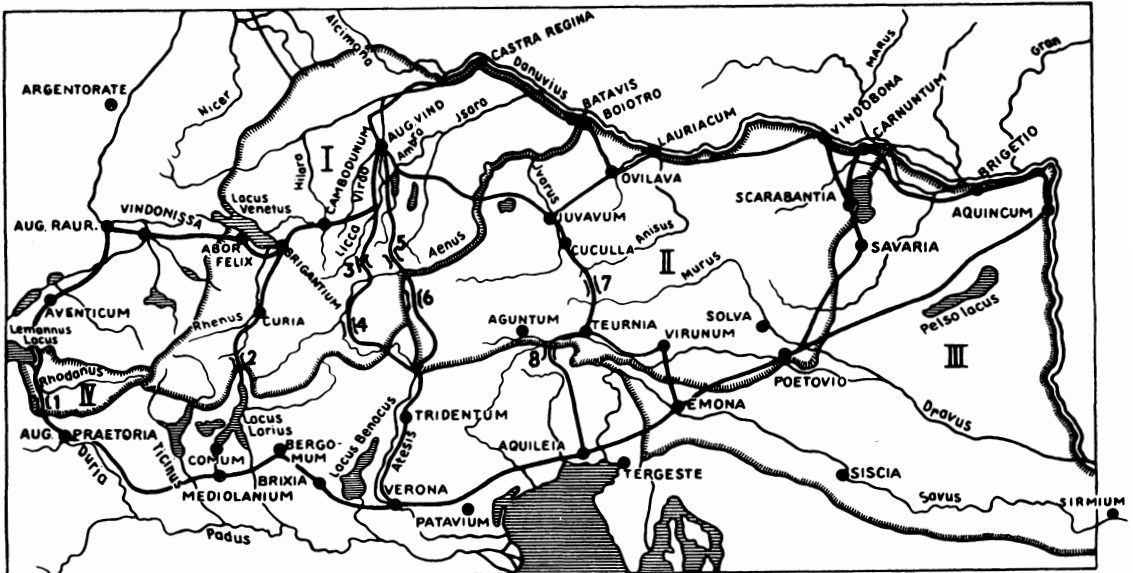

I Raetia, II Noricum, III Pannonia, IV Vallis Poenina

1–8 oppida, viae, saltus Alpium

quadriga –ae, f. / quadrigae –arum, f. pl.

quadriga sunt quattuor equi ad currum trahendum apti; item currus a quattuor equis tractus. in fastigio (*fastigium*) Capitolii quadrigae fictiles fuerunt ornatūs gratiā, currum Iovis referentes. poetice quadrigas etiam Soli, Aurorae aliisque deis tribuerunt.



nummus quadrigatus

quadrivium –i, n.

a) quadrivium est locus, ubi via alteram viam secat, *area*, unde viae in quattuor regiones oriuntur.

b) **quadrivium nominantur quattuor *artes liberales* difficiliore: arithmetica, geometria, astronomia, musica.

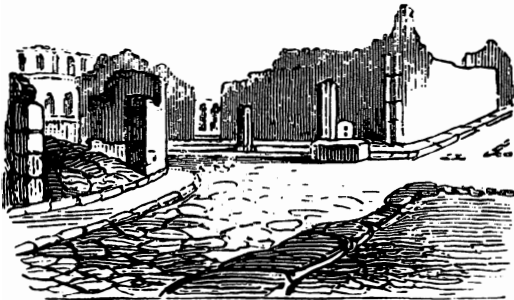

quorsum (quo[ve]rsum)

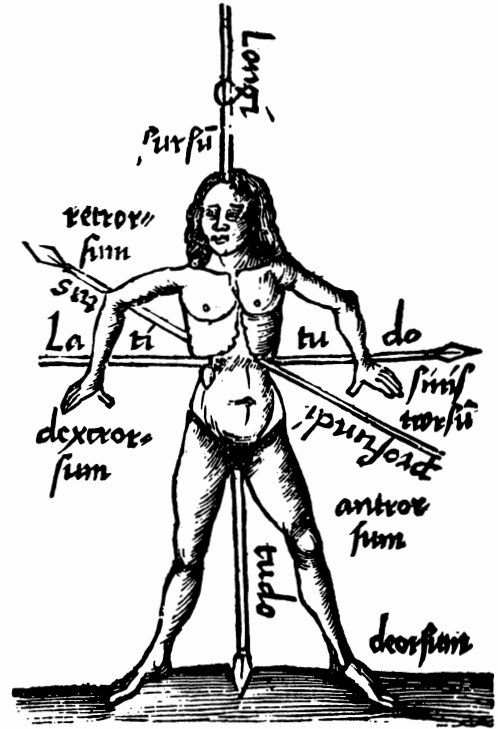

imago sumpta est e Margarita Philosophica Gregorii Reisch (1503)

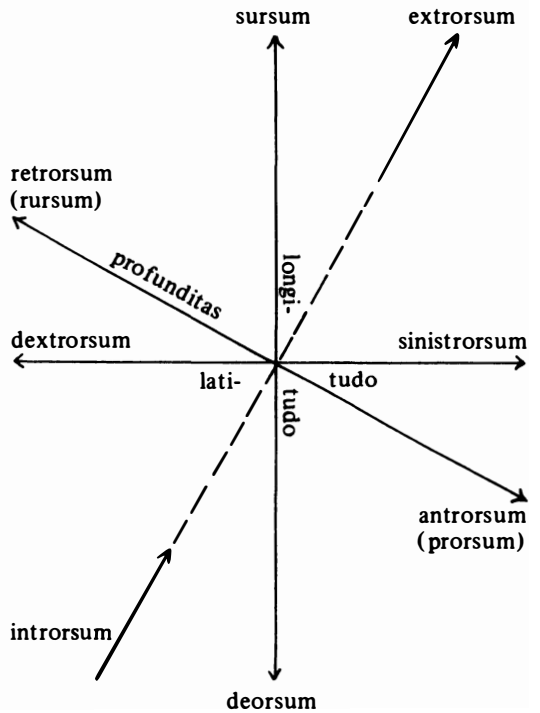

pupa –ae, f.

pupa est imaguncula quaedam puellaris, ex linteo insuta, tomento infarcta, vestibus amicta, qua virgo in prima pueritia lusitare solebat, et quam pubertati vicina tamquam virginitatis suae *insigne* Veneri offerebat, ut fauste futurum matrimonium cederet. pueri eodem tempore bullam (*bullā*) Laribus (*Lares*) offerebant. demin. *pupilla*, –ae, f.

a) plerumque significat filiam orbam parentibus et sub tutore agentem.

b) praeterea pupilla dicitur *foramen* oculi (*oculus*) per quod species rerum ad visum transmittuntur.

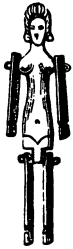

puppis –is (acc. –im, abl. –i), f.

puppis est pars *navis* posterior, altior, ornatio et honoratio, ubi *gubernaculum* et *clavus*.

Vergilius, *Aen.* 3, 130:

„prosequitur surgens a puppi ventus euntes.“
ventus secundus a puppi flat.

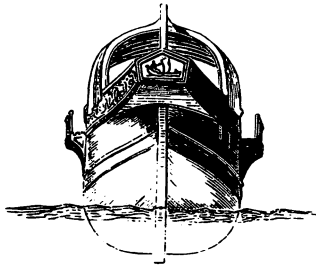

purpura –ae, f.

est concha marina (ut *conchylium*, et *murex*). ex eius suco color purpureus efficitur. captis muricibus enim eximebatur vena et addito sale macerabatur triduo: deinde in *cortina* plumbea decoquebatur. lana immissa quinque horis potabat, rursusque immergebatur, ut totam saniem ebiberet, indueretque colorem illum, qui tanto in pretio quondam fuit.

purpuratus est is, qui purpurā indutus, ornatus est, et speciatim purpurati dicuntur, qui circa reges sunt et apud eos dignitate et gratia antecellunt.

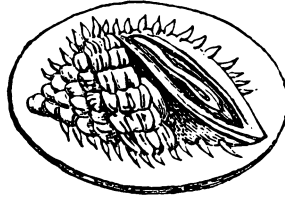

murex in
tinctoris sigillo

puteus –i, m.

est locus, qui perpetuas habet aquas ex terrae venis manantes, non tamen fontium (*fons*) more foras erumpentes.

puteal –alis, n. est saeptum marmoreum, rotundum, puteo circumdatum, ne incautius accedentes in praecipites ruant.



girgillus

puteal

puteus

pyxis –idis, f.

pyxis est vasculum e buxo excavatum, teres, et operculo in ipsum vas intrante clausum et translate accipitur pro vase parvo ex quacumque materia, ad servanda ea, quae plurimum interest bene clausa servari, ne corrumpantur, ut medicamenta, venena, odores et huiusmodi.

Suetonius, *Nero* 12, 9:

„barbam primam posuit, conditamque in auream pyxidem ... Iovi Capitolino consecravit.“



umbraculum

pyxis

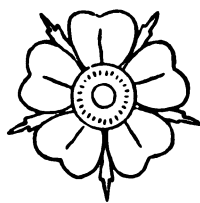

Rosa canina

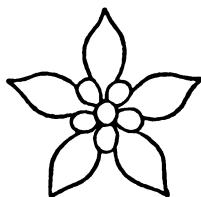

Aquilegia

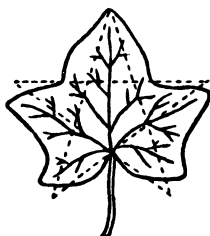

folium Hederae

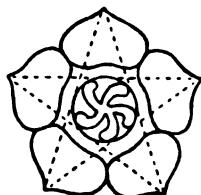

Campanula

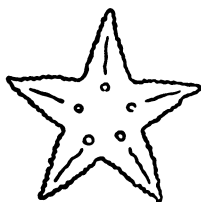

Asterias rubens

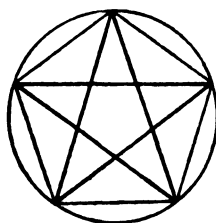

propugnaculum –i, n.

propugnaculum est locus munitus, unde pugnari potest defendendi causā, ut *vallum*, *moenia*, *arx*, aut *turris* in nave (*navis*) constructa.

Tacitus, Hist. 3, 34:

„Cremona ..., propugnaculum adversus Gallos.“

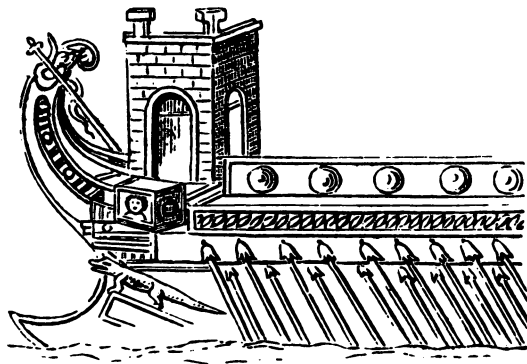

prora –ae, f.

prora est anterior pars *navis*, sicut *puppis* posterior. *navis* cum portum (*portus*) intrat, *prorā* intrat: cum vero religanda est, convertitur et *puppi* religatur, *prora* autem mare spectat (*proreta*).

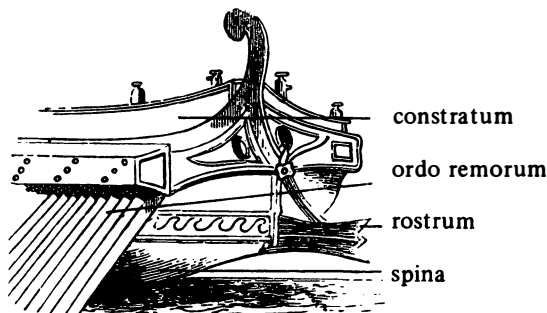

proreta –ae, m. vel proreus

in *navis* *prora* sedet, ibique ventos captat, et de eorum conversionibus gubernatorem monet, docet etiam, rupes et scopuli ubi sint, ut is converso clavo (*clavus*) eos declinet.

Rutilius, de reditu 1, 455, 56:

„despectat *prorae* custos, clavumque sequentem dirigit, et *puppim* (*puppis*) voce monente regit.“

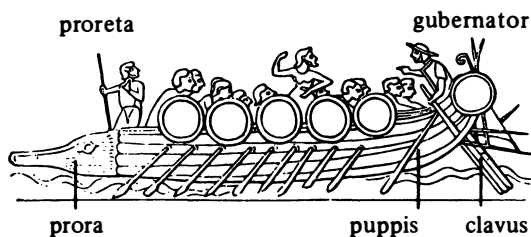

pruna –ae, f.

pruna est *carbo* vivus (aut ardens).

Servius, ad Aen. 11, 788:

„*pruna*, quandiu ardet, dicitur.“

Vergilius, Aen. 5, 103:

„*subiciunt* veribus *prunas* et viscera torrent.“
caro autem in crate (*crates*) ferrea aut in veru, *subiectā* *prunā* (aut carbone ardente) torretur. (*veru*)

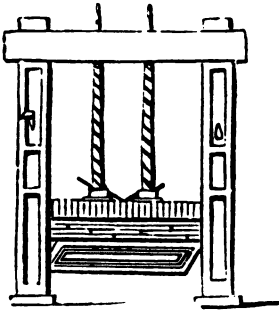

pressio in maius *pistillum* augetur eadem proportione (*proportio*) qua est *superficies* pistilli parvi ad *superficiem* pistilli magni.

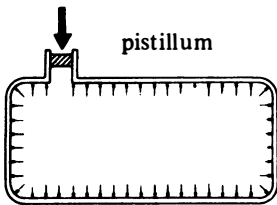

prelum hydraulicum

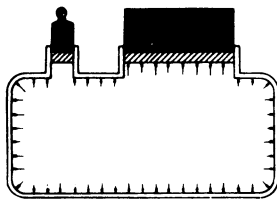

proles —is, f.

est progenies, soboles, liber.

Tibullus, 1, 7, 55:

„at tibi subrescat proles, quae facta parentis augeat...“

proletarius, —a, —um

proprie proletarii erant pauperrimi homines in plebe Romana. fere immunes erant a militia, excepto si tumultus maximus exstitisset. prolem rei publicae procreabant.

proportio —onis, f.

proportio est comparatio et respectus unius rei ad aliam: a „pro“ et „portio“; quia saepe „pro

portione“ Latine dicebatur, paulatim coalescentibus usu frequenti duabus vocibus „proportio“ facta est.

*proportio divina = ***sectio aurea, quod autem nomen saeculo decimo nono huic proportioni datum est. proportio divina a Pythagoreis inventa est.

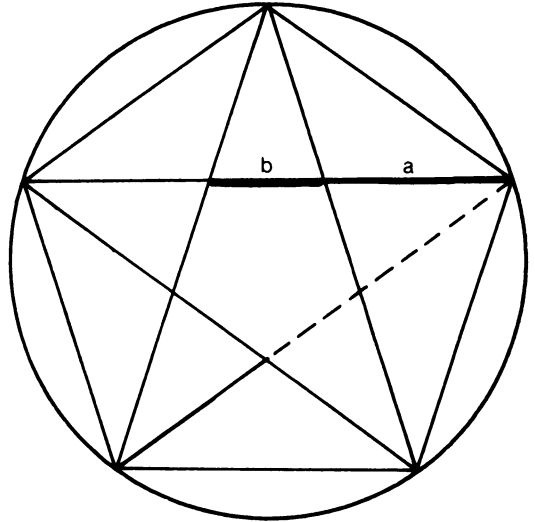

pentagramma sectionem auream praebens:

$$b : a = a : (a + b)$$

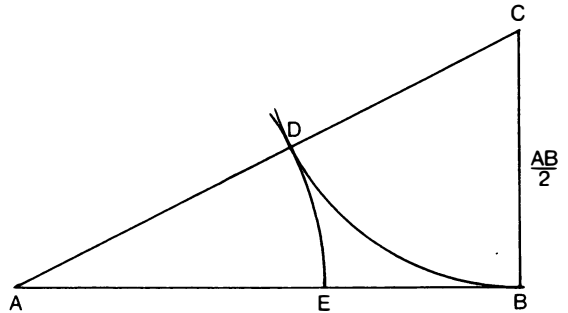

A ————— major ————— minor ————— B

constructio sectionis aureae

$$EB : AE = AE : AB$$

proportionalitas:

Cassidorus, de geometria 6:

„proportionalitas in tribus, ut minimum, terminis invenitur, cum proportionales eidem eiusdem magnitudinis proportionales esse dicuntur, praecedentes consequentibus, et praecedentibus consequentes.“

multis in floribus aliisque a natura procreatis rebus proportio divina reperitur, ut haec exempla monstrant.

praeco —onis, m.

praeco est minister publicus, praedicator, qui voce quaestum facit.

Cicero, Nat. Deor. 3, 34, 84:

haec sublata de fanis in forum protulit et per praeconem vendidit.



praesaepe —is, n. (vel praesaepium, —i, m.)

praesaepe est locus saeptus, in quo pecudes stabulantur; est etiam locus in stabulo (*stabulum*), ubi pabulum iumentis apponitur. praesaepe dicitur etiam de quocumque loco clauso.

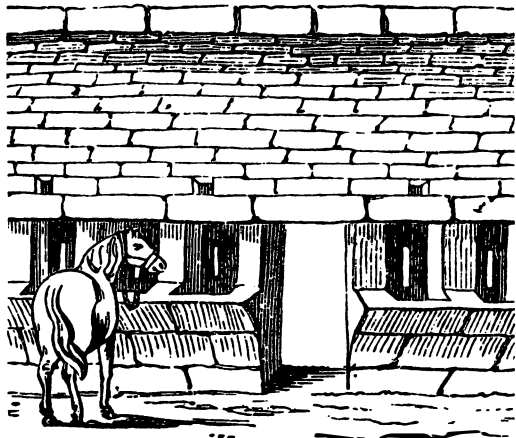

precatio —onis, f.

est rogatio, obsecratio, preces, praesertim quae dis adhibentur.



gestus precandi vel orandi

pressorium —i, n.

est instrumentum ad premendum.

Plinius Valerianus, 2, 17:

„cotonea purgare, tundere diligenter et exprimere in pressorio.“

prelum, —i, n.

est instrumentum, quo uva, oliva, aliudve quid comprimitur ad succum exprimendum vel ad aliquid aequum lucidumque reddendum.

est aditus urbis, vel alterius loci vallo fossave muniti, qua res importantur vel asportantur.
Plautus, Bacch. 711:

„recta porta invadam ex templo in oppidum antiquum et vetus.“

„Hannibal ante portas“ dicitur cum res in summo periculo est.

porticus –us, f.

porticus, ut ait Isidorus, Orig. 15, 5, quasi porta, est locus amplus et longus, columnis aut pilis suspenso tecto munitus, cetera apertus, deambulationis umbraeque et imbrum vitandorum causā. erant privatae, quas ditiores sibi construiebant tum in urbe, tum in agris: erantque

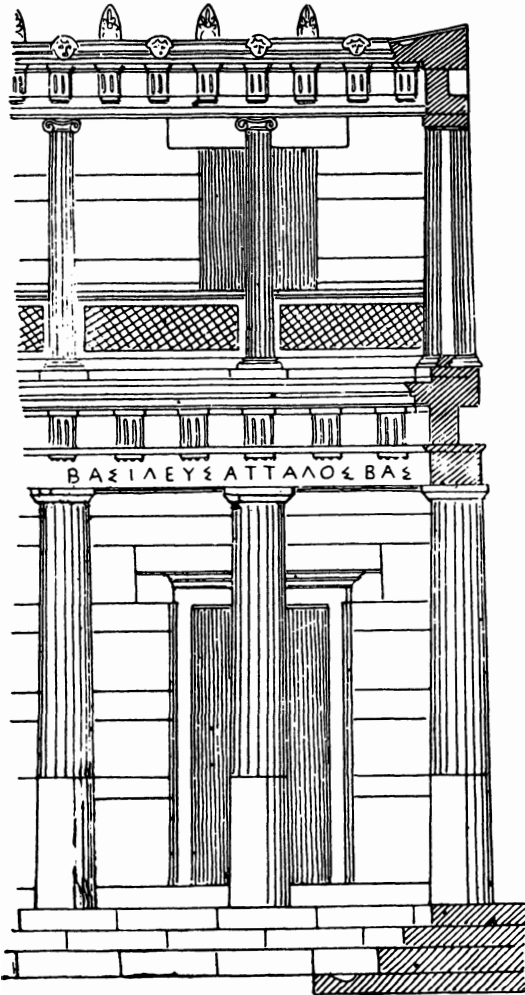

porticus regis Attali, Athenis in foro exstructa

publicae, ingenti sumptu exstructae, signis (*signum*), picturis, marmoribus exornatae, in quibus non solum otiosi homines deambulare solebant, sed aliquando ius dictum, senatum habitum, exceptos legatos legimus; item varia negotia agitata, sponsalia inita, merces pretiosas expositas etc.

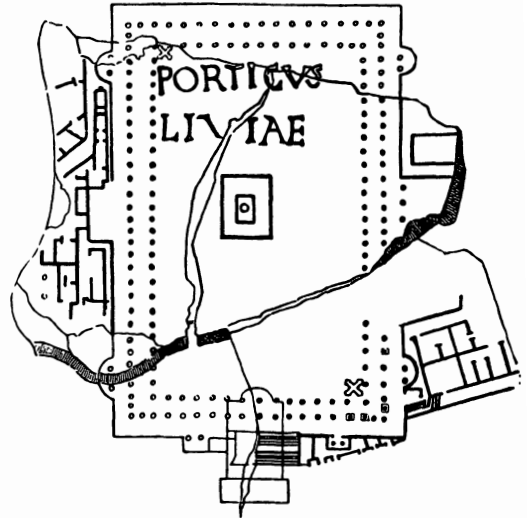

in „Forma Urbis“ in Capitolio Romano expositā ichnographia Porticūs Liviae videtur

portus –us, m.

a) est locus in secessu litoris (*litus*) vel natura vel manu conclusus, aditu in mare patenti, ubi naves consistunt a ventorum iniuriā liberae.

formulae: „in portum ex alto invehī“, „in portum se recipere“.

b) per metaphoram portus est locus tutus.

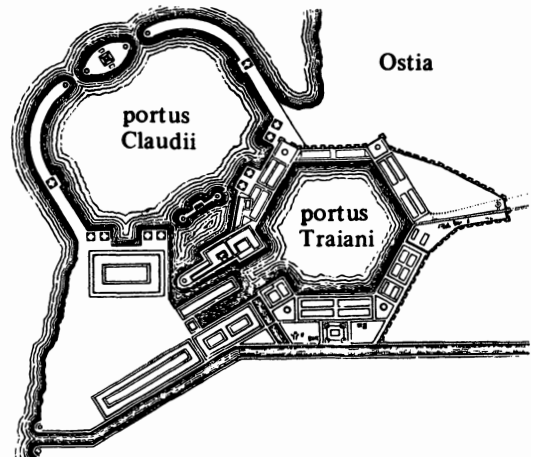

b) pondus abstracte est **gravitas**, momentum, onus.

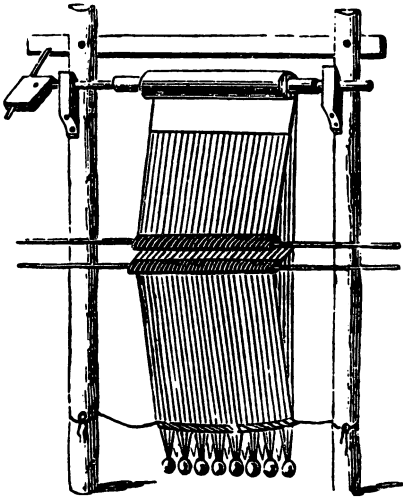

pondera iugi textorii

pons pontis, m.

est id, quo super flumen, vel foveam (*fovea*), vel simile quid transimus.

porta -ae, f.

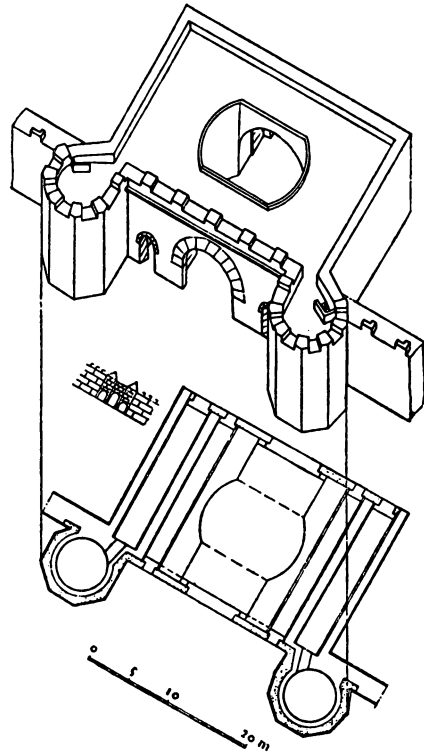

porta orientalis oppidi Helvetici Aventici

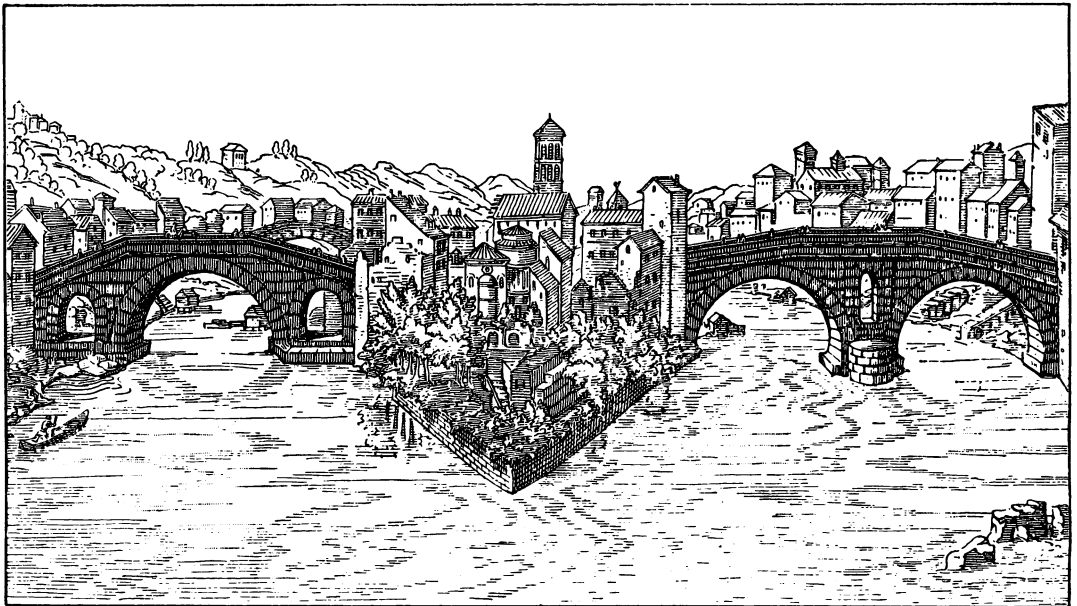

insula in medio Tiberi sita duobus pontibus cum urbe coniungitur: dextrā est Pons Fabricius, sinistra Pons Cestius. primus pons urbis Romae non longe ab hoc loco erat, sed erat **pons sublicius** (*sublica*)

pittacium –i, n.

est schedula brevis seu membranae aut chartae particula, quae alicui rei vel pice vel cera aliave re affigitur, et paucis verbis perscribitur memoriae causa.

Petronius, Sat. 34, 6:

„allatae sunt amphorae vitreae diligenter gypsaetae, quarum in cervicibus pittacia erant affixa cum hoc titulo: Falernum Opimianum annorum centum.“

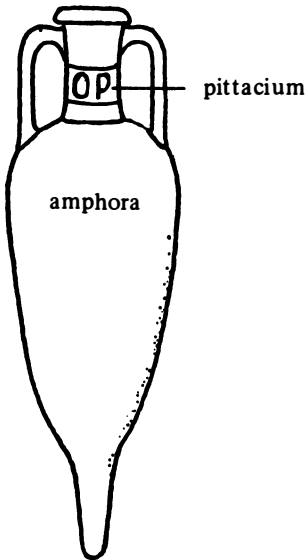

plaustrum –i, n.

est carrus, vehiculum magnis oneribus ferendis aptum, praesertim apud rusticos. Scythae in plaustris habitasse dicuntur, de quibus

Horatius, carm. 3, 24, 9/10:

„campestres melius Scythae,
quorum plaustra vagas rite trahunt domos.“
plaustris sacra Cereris eiusque ministras Athenis et Romae vectare mos erat.

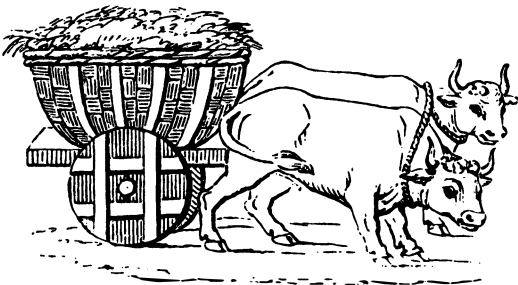

pomarius –i, m.

est pomorum venditor ut in opere caelato sarcophagi describitur.

pomarium, –i, n. est locus pomiferis arboribus consitus, pometum.

Varro, r. r. 1, 2, 6:

„non arboribus consita Italia est, ut tota pomarium videatur?“

pomarium item est locus in villa, ubi poma decerpta conduntur. (*cella*)



pondus –eris, n.

a) pondus est quod adhibetur in *statera* vel lance (*lanx*) ponderandi gratiā.

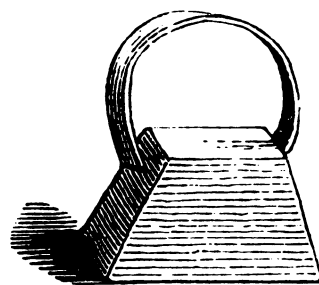

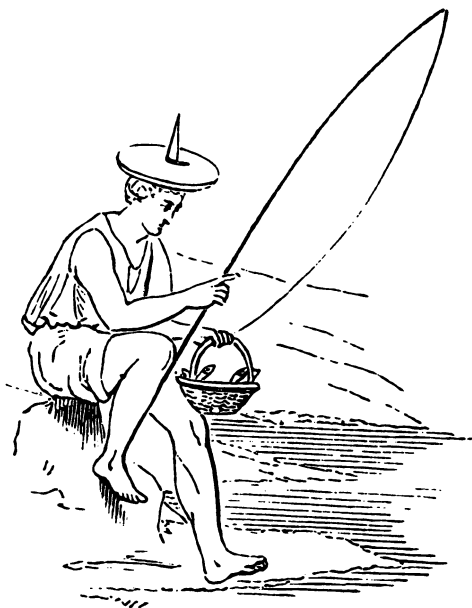

piscina –ae, f.

- a) piscina est lacus vel stagnum, in quo vivi pisces coercentur.
- b) quoniam in piscinis etiam homines natare

solebant, omnes in hunc usum collectae aquae, sive frigidae sive calidae, piscinae dicebantur, quamvis in his nihil piscium sit. (*balneum*)

pistillum –i, n.

pistillum est instrumentum, specie clavae (*clava*), quo grana aliaeque res in mortario (*mortarium*) teruntur.

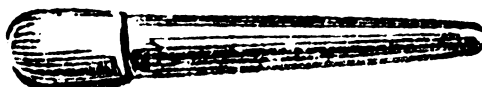

pistor –is, m.

qui farinam subigit panemque conficit.

Plinius, N. H. 18, 11, 28, 107:

„pistores Romae non fuerunt ad Persicum usque bellum ... ipsi panem faciebant Quirites (= Romani), mulierumque id opus maxime erat, sicut etiam nunc in plurimis gentium.“

pistrina est *officina* pistoris.



opus caelatum sarcophagi Romani: in parte superiore aratores agrum laborant, in parte inferiore ad dextram molam (*mola*) agitant, ad sinistram pistor panes in fornacem (*fornax*) immittit

pileus –i, m. (vel –eum n.)

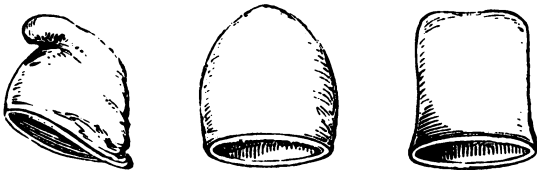

est tegmen et indumentum virile capitis, pilei figura fere similis erat dimidio ovi (*ovum*) putamini.

Paulus Diaconus, p. 207, 4 M.:

„pilea *Castori et Polluci* dederunt antiqui, quia Lacones fuerunt, quibus pileatis pugnare mos fuit.“ (*manumissio*)



pileolus

pinna –ae, f.

a) est id, quo aves vestiuntur; differt a pluma, quae tenuior est, mollior et densior, totumque corpus tegit.

b) murorum et turrium et valli cacumina, quae in acutum per intervalla desinunt, pinnae vocantur.

Caesar, B. G. 7, 72, 4:

„aggerem et vallum ... extruxit, huic lorica pinnaeque adiecit.“

pinnae moenium

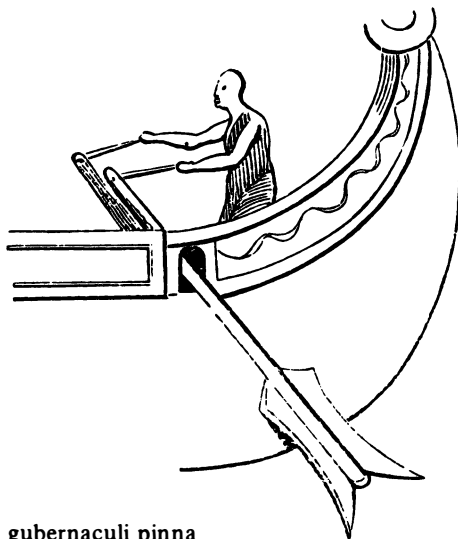
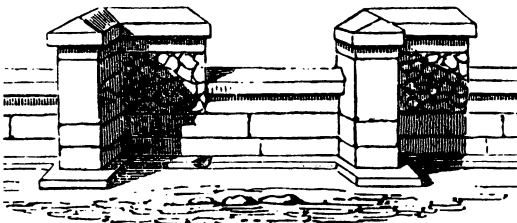

gubernaculi pinna

pinus –us (vel –i), f.

est arbor ex earum genere, quae resinam fundunt, in magnam altitudinem se promittens, ramosa in vertice (*vertex*), folia habens capillamenti modo praetenuia, longa, mucrone aculeata et numquam decidentia. nucamentum pinus sacrum erat Baccho. *symbolum* vitae aeternae erat ideoque saepe in monumentis sepulcralibus invenitur.



piscator –oris, m.

piscator est is, qui piscatur aut pisces captos publice vendit. capiuntur pisces hamo (*hamus*), reti (*rete*), aut *nassa*.

adi. piscatorius: piscatoria *navis*; in *taberna* piscatoria vel in foro piscatorio pisces v̄neunt.

b) pictura in linteo vel in sipario,



pictura
in linteo

- c) pictura inusta,
d) pictura udo tectorio (*tectorium*),
e) pictura textilis, vel imago acu (*acus*) picta.

pīla –ae, f.

pila est sphaera, globus, quo luditur.
Petronius, Satyr. 27:
pilam repetere, quae terram contigit.
Plautus, Captivi, 22:
„enimvero dii nos quasi pilas homines habent.“



pīla –ae, f.

a) pila est *mortarium*, vas aeneum, lapideum aut ligneum, in quo aliquid pinsitur et comminuitur.

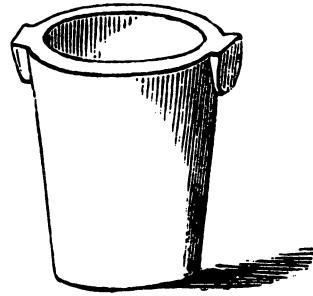

b) pila est structura erecta in modum columnae, ad aliquid fulciendum. differt a columna, quae uno scapo constat, h. e. lapide oblongo perpetuo: pila vero structilis est pluribus lapidibus aut lateribus.

Livius, 40, 51, 4:

„locavit pilas pontis in Tiberim: quibus pilis fornices (*fornix*) post aliquot annos ... locaverunt imponendos.“

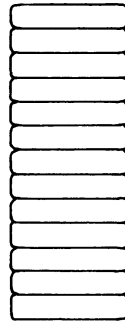

- c) pila item est saxea moles, quae praestruitur littori ad frangendam undarum vim.
d) ***pila electrica

pilae elementum:

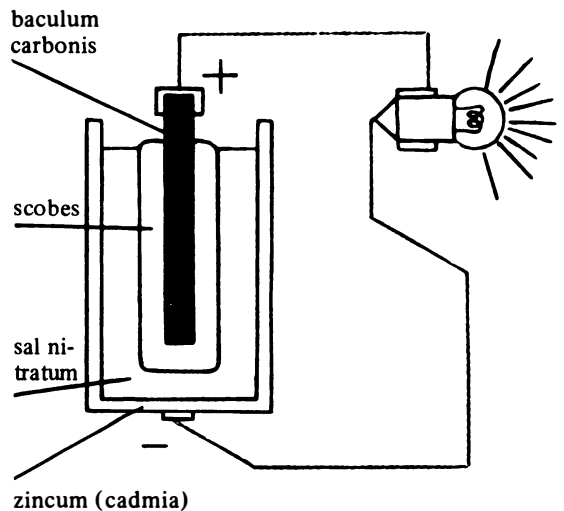

b) translate est navigii genus, mixtam formam habens ex oneraria et longa triremi, quod tam velis quam remis agi poterat; brevis est navicula, qua naves maiores in alto mari versantes conscendebantur.

fictiles etiam phaselos in usu fuisse apud Aegyptios testatur Iuvenalis, 15, 127:

„parvula fictilibus solitum dare vela phaselis.“
phaselus est „navium celerrimus,“ Catullus 4, 2. .

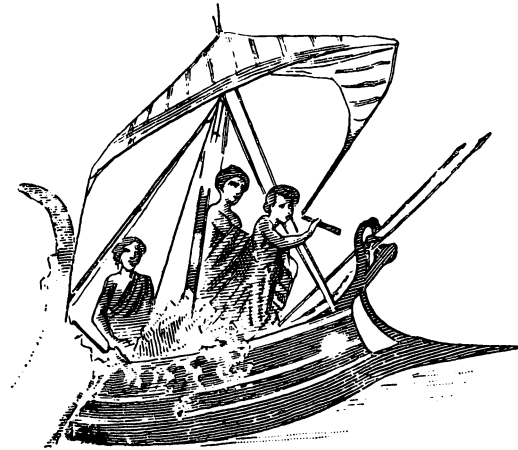

Phrixus et Helle

Phrixus, cum ab Ino noverca ad necem quaeretur, una cum Helle sorore profugit, raptu ariete velleris aurei (*vellus aureum*), in quem conscendentes mare transmittebant. sed ad fretum Aegaei Helle exterrita decidit mersaque est Hellespontoque nomen dedit. Phrixus vero incolumis in Colchidem pervenit ad regem Aecten, ubi, Iovi ariete mactato, aureum vellus Marti sacravit; quod, a dracone custoditum, Iason cum Argonautis ope Medeae inde abstulit. aries autem intra sidera translatus est. (*Argo*)

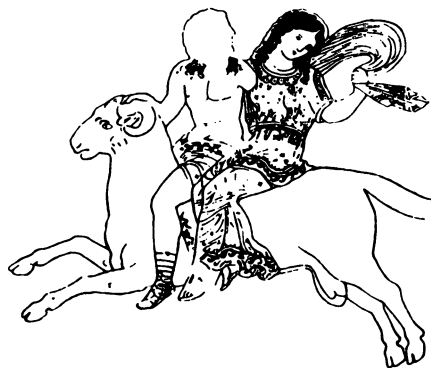

pictor –oris, m.

nomen agentis, derivatum a verbo pingere (pinxi, pictum). actio pictoris est pictura, i. e. actionum statuumque imitatio colorum linearumque ope perfecta.



imago officinam pictoris monstrat: 1 machina pictoris 2 discus colorum 3 peniculus vel penicillus 4 sella 5 exemplar, simulacrum

pictura –ae, f.

pictura est ars pingendi; metonymice sumitur pro tabula, vel tela, vel alia re picta.

Cicero, Verr. 4, 1, 1:

„nego ullam picturam neque in tabula, neque textilem fuisse, quin conquisierit (sc. Verres), inspexerit, quod placitum sit, abstulerit.“

hae picturae distinguuntur:

a) pictura in tabula (sc. lignea),

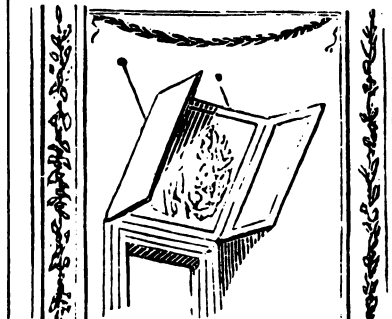

pictura in tabula



personatus,
personam senis
gerens.
personatus est
is, qui personā,
larvā indutus
est.

pharmacopola —ae, m.

facit et vendit remedia et unguenta omne genus.



in opere caelato sarcophagi delineatum est
pharmacopolium variis vasis et instrumentis
instructum, in sinistra parte est *mortarium*
cum *pistillo* (*pistillum*)

pharus —i, f.

a) Pharus erat oppidum Aegypti apud Alexan-
driam; in ea ingens *turris* erat, ex qua lumen per
noctem navigantibus elucebat.
b) hinc etiam machinae in portubus (*portus*)
idem officium navigantibus praebentes, phari
nominabantur.



imago nostra pharum portūs Ostiensis monstrat,
simulque navem e portu altum mare petituram.
(in velo navis depicta est lupa Romulum Re-
mumque lactans.)
opus caelatum e collectione Torlonia

phaselus —i, m.

a) proprie est genus leguminis, quod quidam in
duo genera dividunt, maius et minus. (in re botanica:
phaseolus vulgaris et vicia faba)



perpendiculum –i, n.

est instrumentum fabri materiarii seu caementarii, quo plumbo a filo pendente rectitudo aut obliquitas operis perpenditur et examinatur. eius inventor fuit Daedalus.

Plinius, H. N. 36, 23, 51:

„structuram ad normam (*norma*) et libellam (*libella*) fieri, ad perpendiculum respondere oportet.“

Vitruvius, 6, 8, 5:

„uti omnes structurae perpendiculo respondeant, neque habeant in ulla parte proclinationes.“

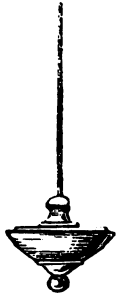

perpendiculum

persona –ae, f.

a) est larva histrionalis, h. e. ficticia facies, qua fabularum actores utebantur, totum caput obtegens, aversā parte capillamento instructa, adversā humanum vultum senis aut adulescentis aut mulieris etc. referens, ore tamen iusto latiore et rotundo, qua vox exiret facilius.



tragoediae personae



comoediae personae

b) latiore sensu a similitudine dicuntur personae simulacra et imagines (*imago*), hominum aut animalium capita vultusque ferentes.

c) translate persona dicitur ipse actor et histrion, hinc in fronte fabularum Plauti et Terentii enumerantur personae, quae in iis inducuntur loquentes.

d) persona est conditio, status, munus, quod quisque inter homines et in vita civili gerit.

Cicero, Quinct. 13. 45:

„petitoris personam capere, accusatoris deponere.“

e) persona pro homine absolute usurpatur:

Paulus, Dig. 1, 5, 1:

„omne ius, quo utimur, vel ad personas pertinet, vel ad res, vel ad actiones.“



meretricis persona



senis persona

***pediludium –i, n.

est lusus pilae, quo pila pedibus impellitur aut capite, numquam manibus aut corpore. haec est collocatio lusorum:

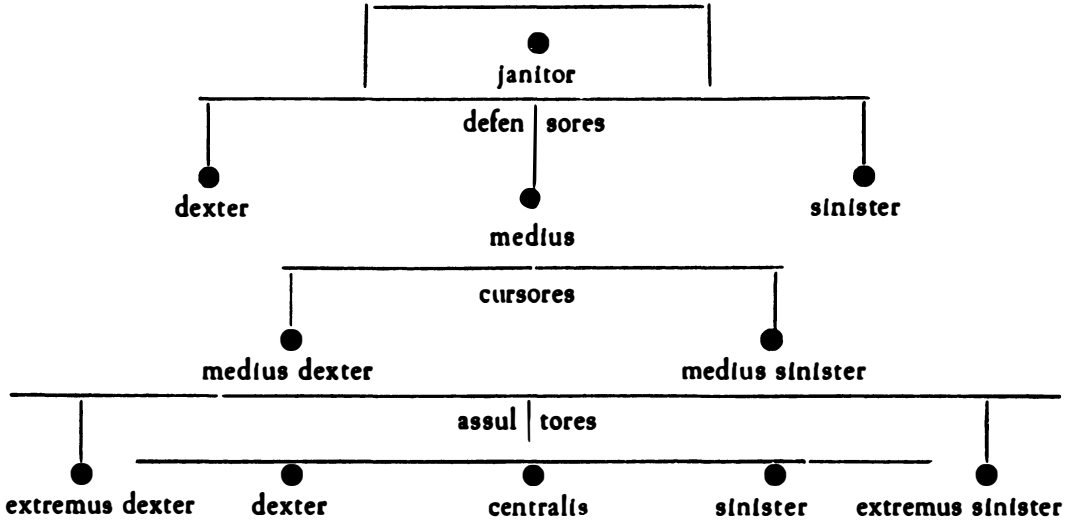

pergula –ae, f.

pergula est locus extra parietem (*paries*) porrectus, saepe tectus vineis aliisque plantis, ubi in umbra deambulatur. (italiane: pergola)

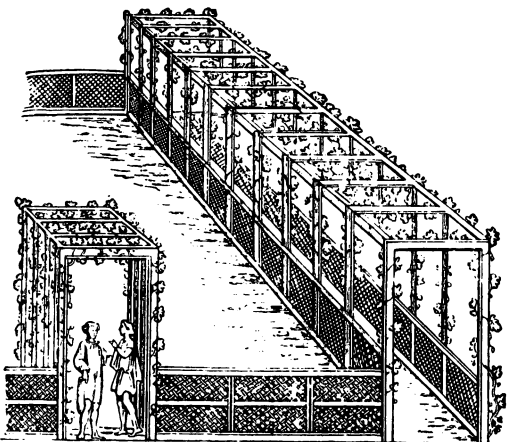

picturae murales Romanae pergulas exhibentes



pavimentum —i, n.

est domus solidamentum, sive incrustatio, quam gradiendo inculcamus (*domus Romana*).

Cato, r. r. 18, 7:

„ibi de *testa* arida pavimentum struito, ubi structum erit, pavito, fricatoque oleo, uti pavementum bonum siet.“

a verbo „pavio (—īvi, —itum, —īre)“ = caedere, tundere, pulsare. formula dicendi: terram aut solum pavīre = tundendo calcandoque solidare.

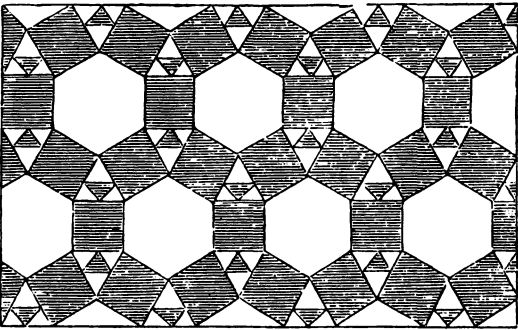

pecten —inis, m.

pecten est instrumentum comatorium densis dentibus instructum ad capillos explicandos.

Plautus, *Captivi* 268/69:

„... utrum strictimne attonsurum dicam esse an per pectinem,

nescio ...“

h. e. longius a cute, pectine interposito.

verbum: pecto, pexi, pexum, pectere = componere et ornare capillos pectine.

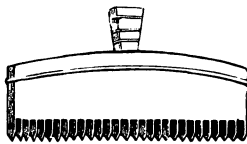

pecten
„denso dente“

pavo —onis, m.

est avis vario pennarum fulgore conspicua, quam poetae Iunoni tutelae assignarunt, cuius illa caudam ornasse fingitur oculis Argi a Mercurio interempti.

mos fuit flabella (*flabellum*) ex caudis pavonum facere ad abigendas muscas.

**in operibus artis Christianae pavo est *symbolum* vitae aeternae.

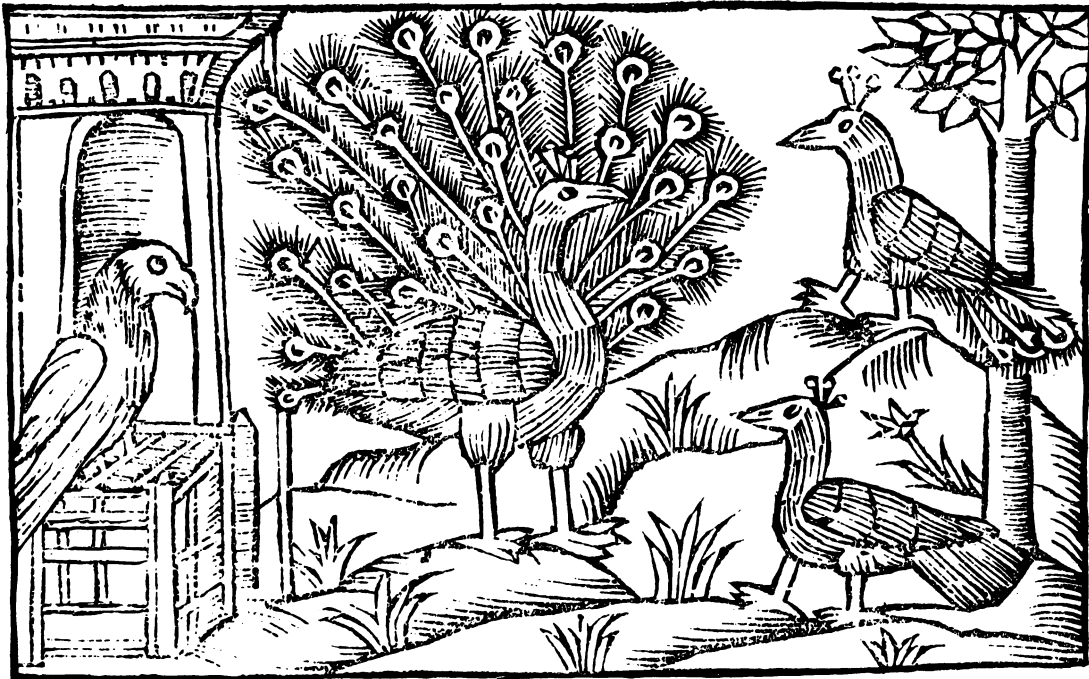

nullo semine, aut usu eius alio, quam floris, ad deos coronandos.“

e libro (*liber*) interiore papyri praeparantur chartae. texuntur plagulae libri et conglutinantur suco papyri, prelis (prelum) premuntur et sole siccantur.

Parcae –arum, f. pl.



tres sorores, filiae Noctis erant, quarum prima Clotho, secunda Lachesis, tertia Atropos nominari solent. filium illae vitae humanae nere, semperque pensa sua trahentes finem quoque vivendi cuique hominum definire dicuntur. Clotho nomen a verbo Graeco „klotho“ = neo derivat, Lachesis cuius appellatio a „langchanein“ = sortiri, originem trahit, tertia Atropos ideo dicitur, quod immutabilis sit („trepo“ = verto). in opere caelato Clotho fusum (1) tenet et filum net, Lachesis filum forficibus (2) secat, Atropos fatum globo mundi (3) declarat.

paries –etis, m.

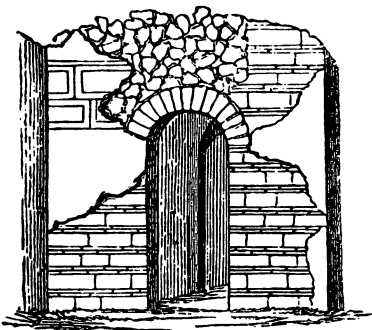

paries est murus domum aliudve privatum aedificium ambiens et sustinens; differt a muro, nam hic est fere publicus et urbem cingens.

paries craticius est *crates* e viminibus facta lutoque intecta.

paries latericius est lateribus (*later*) structus, ut in imagine videtur.

„intra parietes“ est domi, privatim.

proverbium: „in caducum parietem inclinare“, dicitur de eo, qui nititur rei parum firmae.

„duos parietes de eadem fidelia dealbare“, de eo, qui apud omnes, etiam adversos inter se, gratiam inire quaerit.

Horatius, ep. 1, 18, 84:

„nam tua res agitur, paries cum proximus ardet.“

patena –ae, f.

patena (aut patina) est vasis genus, quo utebantur ad condiendos et coquendos pisces et alia.

Phaedrus, 1, 26 ss.:

„Vulpes ad cenam dicitur ciconiam prior invitasse, et illi patinā liquidum posuisse sorbitionem ...“



patera –ae, f.

est poculi genus planum ac patens, cuius usus in sacris plurimus.

Varro, L. L. 5, 122:

„(pateris) etiam nunc in publico convivio, antiquitatis retinendae causā, cum magistri fiunt, potio circumfertur; et in sacrificando deis hoc poculo magistratus dat deo vinum.“

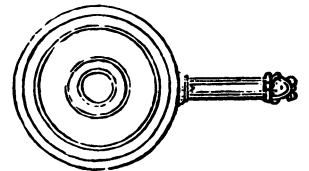
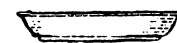
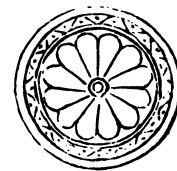

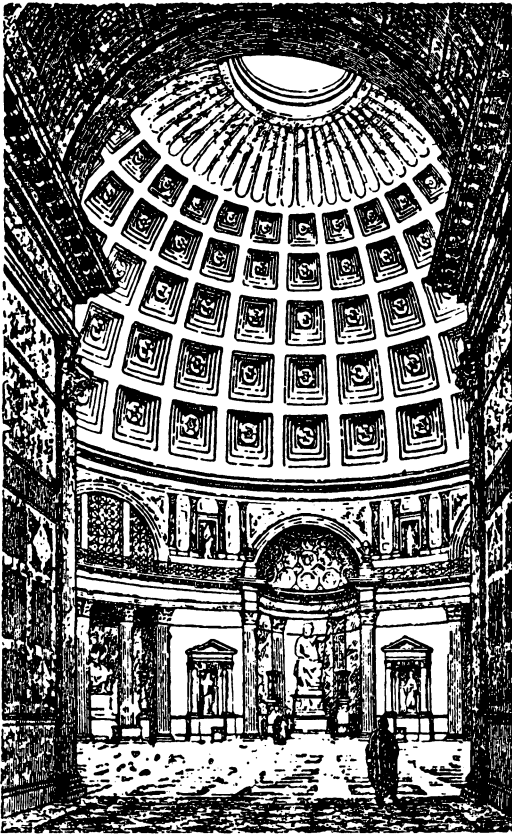

a) est insectum alatum luminibus accensis advolitans, ignavum et inhonoratum, apibus inimicum, cerasque earum depascens, et excrementa relinquens quibus teredines gignuntur: fila (*filum*) etiam araneosa (*arana*), quacumque incessit, alarum maxime lanugine obtexens.
 b) translate est militare tentorium, quia expansa vela habet ad similitudinem alarum papilionum.

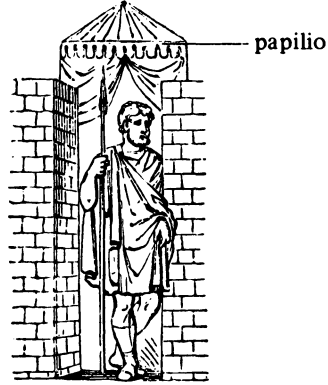

papyrus -i, m. vel f.

Plinius, H. N. 13, 11, 22:

„papyrus nascitur in palustribus Aegypti, aut quiescentibus Nili aquis, ubi evagatae stagnant, duo cubita non excedente altitudine gurgitum (*gurgis*), brachiali radice obliquae crassitudine, trianguli lateribus, decem non amplius cubitorum longitudine in gracilitatem fastigatam, thyrsi (*thyrsus*) modo cacumen includens,

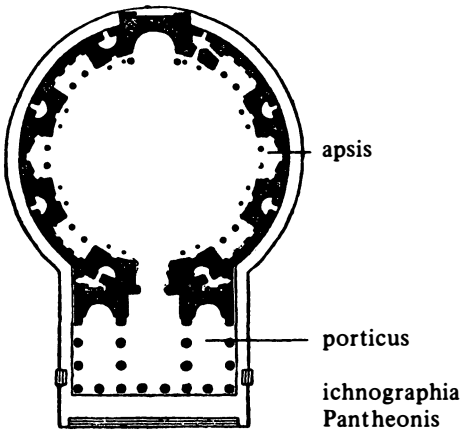

papilio -onis, m.

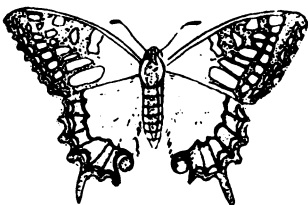

Pantheon Romanum

vulgo Rotundum nominatur, ab Agrippa seu constructum seu instauratum; porticu (*porticus*) sedecim columnarum (*columna*) Corinthiarum ornatum est, unicum templum Romanum quod adhuc hodie integrum conspicitur. Lux in eo superne per magnum foramen in fornix (*fornix*) medio constructum intrat. in interiore templi circuitu septem magnae apsides (*apsis*) sunt, totidem deorum (fortasse Planetarum) statuis collocandis destinatae. fornix totius templi inaurato aere opertus fuit, quod aes olim ab imperatore Constantio II sublatum est. traves aeneae porticus a papa Urbano VIII sublatae sunt, ut baldachinum ecclesiae Sancti Petri et tormenta bellica in arce (*arx*) Sancti Angeli collocanda funderet. De quo papa scripsit poeta quidam: „quod non fecerunt barbari, fecerunt Barberini“ nam Urbanus VIII e gente Barberini oriundus erat.

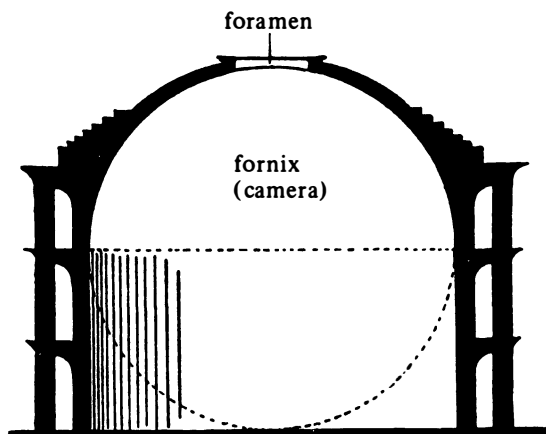

orthographia Pantheonis



mum condita est. haec regio urbis Palatium nominabatur.

b) sub imperatoribus ibi aedes maximae immensis sumptibus exstructae sunt: unde factum est, ut domus principis palatium vocaretur.

palimpsestus –i, m.

est membrana iterum abstersa *spongiā*, ut in ea scribi pluries possit.

Cicero, ad familiares, 7, 18, 2:

„nam quod in palimpsesto (sc. scripsisti), laudo equidem parsimoniam, sed miror, quid in illa chartula fuerit, quod delere malueris, nisi forte tuas formulas.“

codex palimpsestus = codex rescriptus. (a verbo graeco palin psao = iterum abradere.)



pallium –i, n.



pallium est quicquid cooperiendo corpori inseruit; speciatim pallium est vestis longa, fusa et ampla, quae tunicae induitur: propria est Graecorum, tum virorum, tum mulierum, sicut toga Romanorum et Itolorum.

adj. palliatus = pallio amictus: et fere apud Latinos de Graecis dicebatur. fabulae palliatae sunt quae Graecos mores, Graecosque homines inducunt; contra togatae, quae Romanos Italosve.

paludamentum –i, n.

dicitur de veste militari imperatorum et ductorum exercitūs: sagum enim in universum appellabatur vestis militaris, sed imperatoris proprium erat paludamentum.



palus –udis, f.

palus est aqua stagnans, quae aestate plerumque siccatur; in quo differt a lacu, qui perpetuam habet aquam.

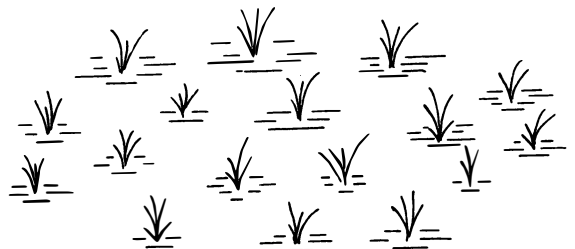

paeninsula –ae, f.

est terra undique fere aquis clausa, una tantum parte, eaque angusta, continenti adhaerens: a „paene“ et „insula“, quia quasi insula est. promonturium paeninsula est abrupta et saxosa.

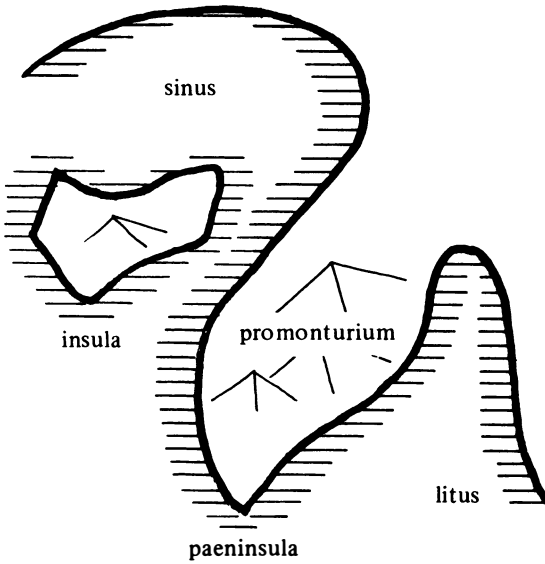

pagus –i, m.

pagus sunt plures vici aut villae simul positae, nullo moenium ambitu.

speciatim Germaniae et Galliae populi eorumque regio in pagos dividebatur, qui erant pars ampla regionis.

adi. paganus, ad pagum pertinens.

**apud ecclesiasticos scriptores paganus est, qui gentilium superstitionem retinet et falsos deos colit, quia cum Christiana religio passim vigere coepit in urbibus, in solis pagis et villis illa servabatur.

pala –ae, f.

est instrumentum ferreum, rusticum, ligoni (*ligo*) simile, sed planum et latius, quo terra versatur, egeritur, vel aggeritur.

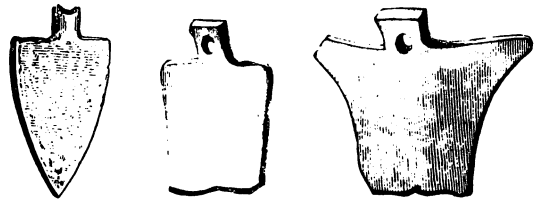

palatium –i, n.

a) mons Palatinus, unus ex septem collibus (collis) urbis Romae (septimontium), in quo urbs pri-

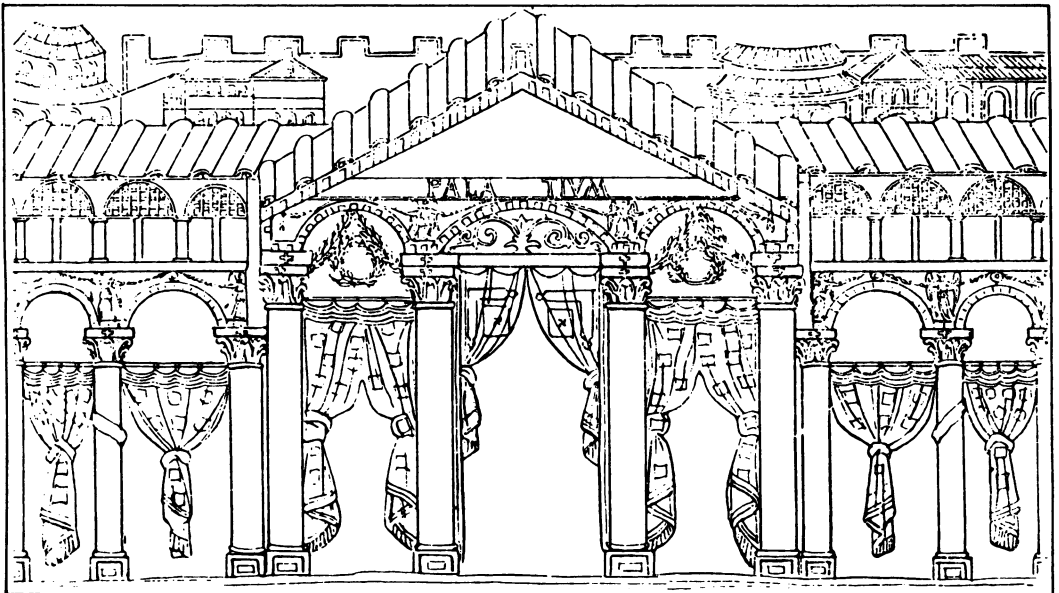

palatium Theodosii Ravennae situm

oscillatio –onis, f.

est iactatio per funem (funis); ritus et ludi genus.



oscillatio

oscilla sunt parvae imagunculae, seu parvae *statae*, quae arte fictili fingebantur et quas arboribus appendebant ut campi a deo, cuius imaginem portabant, protegerentur.

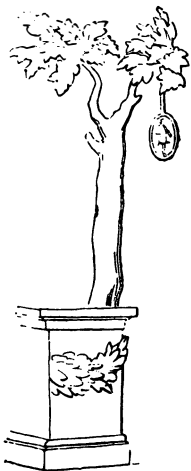

oscillum in arbore sacra prope aram (*ara*)

ovum –i, n.

ovum est fetus avium, piscium et quorundam animalium terrestrium, unde pulli fovendo excluduntur. ovi partes sunt vitellus, seu luteum ovi, et albumen seu album, quod putamine, seu cortice continetur.

dictum: „ab ovo usque ad mala“ narrare aliquid, i. e. ab initio usque ad finem narrare, nam convivis primum ova apponi solebant, in secunda mensa varia genera mälorum.

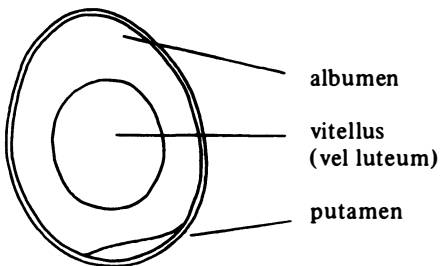

orbis terrarum

est circulus earum terrarum vel regionum, quae Mare Nostrum (vel Mare Internum, vel Mare Mediterraneum) circumdant et universae Oceani circulo cinguntur. talem Homerus in Achillis clipeo (*clipeus*) universam terram repraesentat.

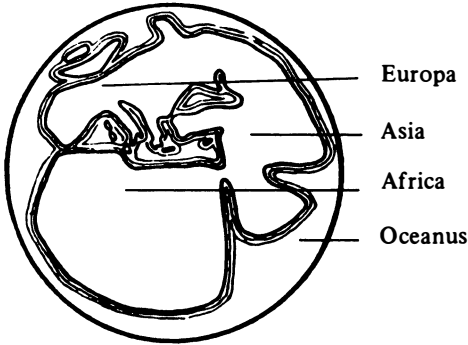

Europa
Asia
Africa
Oceanus

OS oris, n.

os est interior pars faciei, apta ad edendum, spirandum et loquendum. consonantes, quae in labiis formantur, labiales, quae in dentibus dentales, quae in palato palatales, quae in velo velares, quae in guttur gutturales nuncupantur.

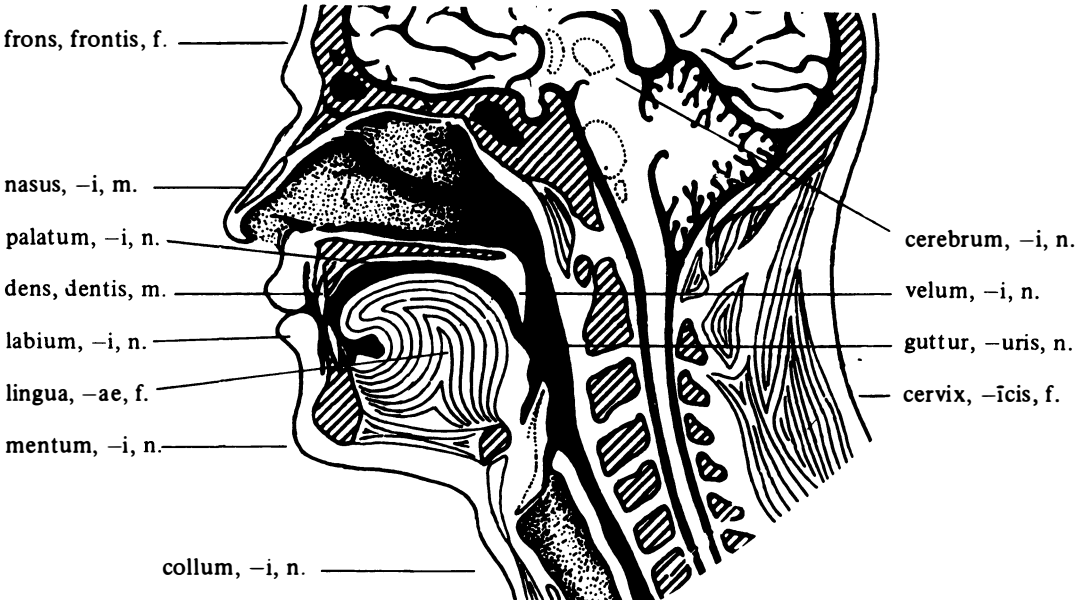

OS OSSIS, n.

ossa capitis sunt calvaria (1), et duae maxillae (2) cum dentibus; spina dorsii (3), quae constat 34 vertebrae (4), costae (5), duae scapulae (6), os sessibuli (7), lacertus (8), tibia (9), fibula (10) anterior et posterior (11). in ossibus est medulla.

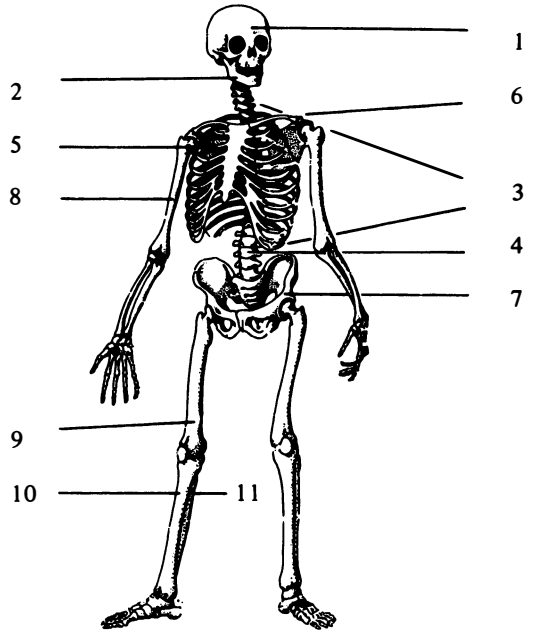

ossa hominis

personae; id in quod quisque debet incumbere, ut ipsum pro loci, temporis et personae qualitate reddat effectum.

Terentius, Eun. 729:

„postquam surrexi, neque pes neque mens satis suum officium facit.“

opus –eris, n.

est id quod fit operando; differt ab operā, quae est actio, qua fit opus.

opus alexandrinum

est opus tessellatum eius generis, quod Alexandriae factum est.

opus incertum, incerta caementa alia super alia sedentia inter seque implicata, non speciosam, sed firmiorem quam reticulata praestant structuram.

opus reticulatum

reticulata structura parietum est, cum lapidei cunei sibi invicem superpositi et in latus iacentes ita parietem convestiunt, ut eorum capita foris exstantia, retis (*rete*) figuram referant.

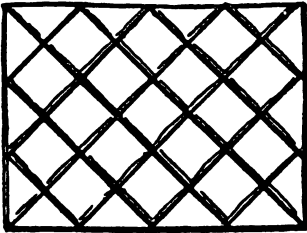

opus spicatum

est pavimentum aut structura parietum ex laterculis seu testis (*testa*) in modum spicae (*spica*) dispositis.

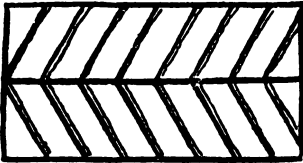

opus tessellatum est pavimentum parvis lapillis (*tessellis*) compositum.

oraculum –i, n.

est deorum responsum.

Seneca, Contr. 1, praef., 9:

„Quid est enim oraculum? nempe voluntas divina hominis ore enuntiata.“

Socrates omnium sapientissimus oraculo Apollinis iudicatus est.

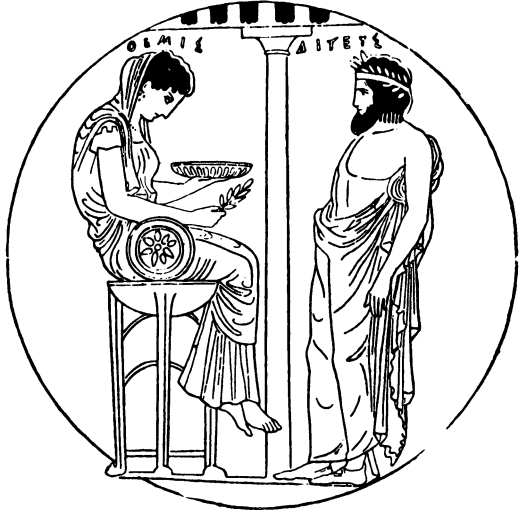

in imagine vasis Graeci picti Pythia (nomine Themis) in tripode (*tripus*) sedet, manu sinistra pateram, manu dextra ramum lauri tenens, responsum (= oraculum) Apollinis effatur Aegaeo regi Atheniensium

orbiculus –i, m.

a) est parvus orbis, circulus, rotula.

b) genus machinae, quae Graece polyspaston appellatur, quod multis orbiculorum circuitionibus et facilitatem summam praestat et celeritatem ad attollenda onera gravia.

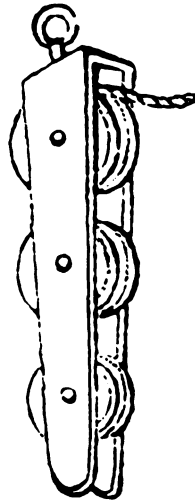

oculus –i, m.

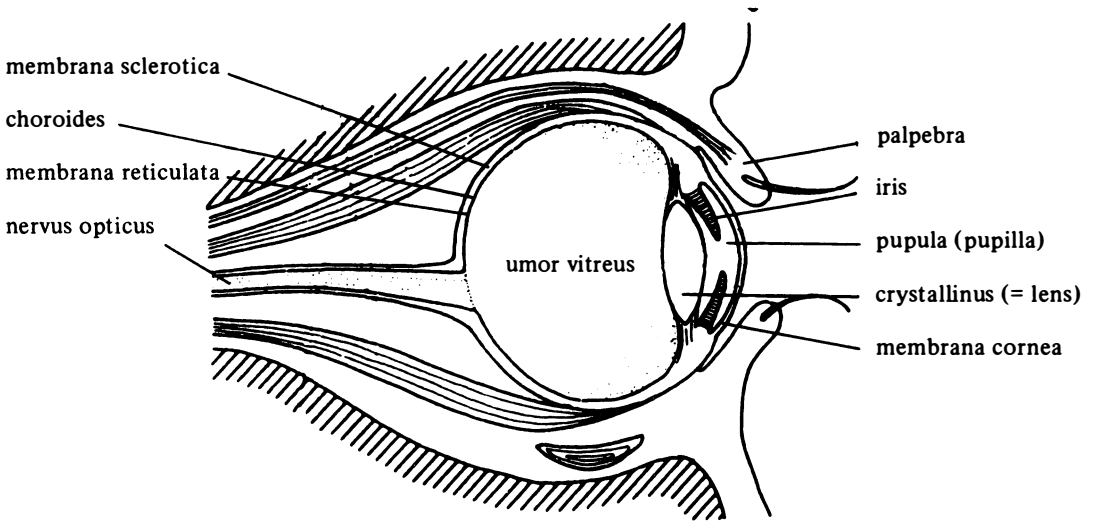

octogonum –i, n.

adi. octogonus, i. e. octo angulos habens, octangulus; Graecum, ex octo et gonia, „angulus“.
Vitruvius, 1, 6, 4:
 turris marmorea octogona.

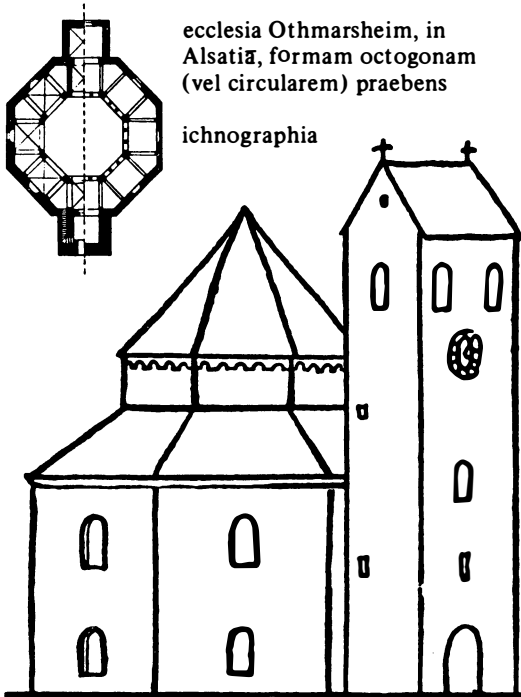

officina –ae, f.

est locus, in quo *artifices* opera faciunt; differt ab apotheca, in qua res conditae asservantur, et a taberna, in qua venales prostant.
Plinius, N. H. 11, 37, 72:
 „pulmo spirandi officina, attrahens ac reddens animam.“



fusoris officina (ex opere Olai Magni)

officium –i, n.

est id, quo quis vel quid pro natura sua fungi debet; praestatio eius operis, quod quisque vel quidque praestare debet; quod quisque efficere debet, observata locorum temporum et personarum ratione; congruus actus uniuscuiusque

obeliscus –i, m.

obeliscus est lapis, artificium manu elaboratum et ad rei memoriam erectum, forma *veru* similis. primum obelisci monumenta regum Aegyptiorum fuerant, deinde etiam Romam translata sunt.



ocularia

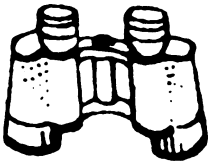

perspicilla specularia



specillum



vitra ocularia (perspicilla)

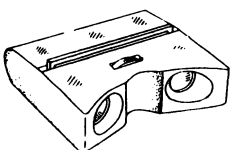

stereoscopium

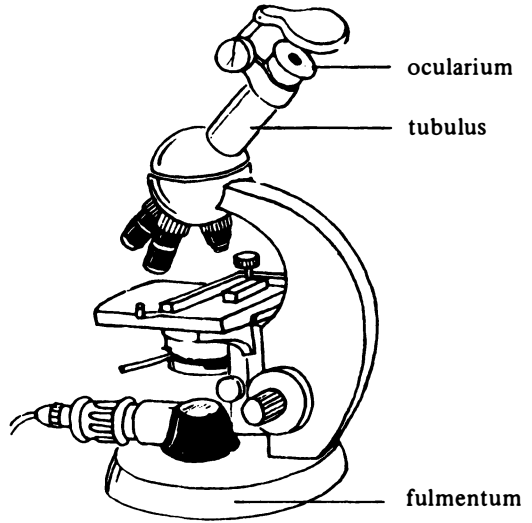

microscopium

lentes convergentes



biconvexa



plana convexa



concava convexa

lentes divergentes



biconcava



plana concava



convexa concava

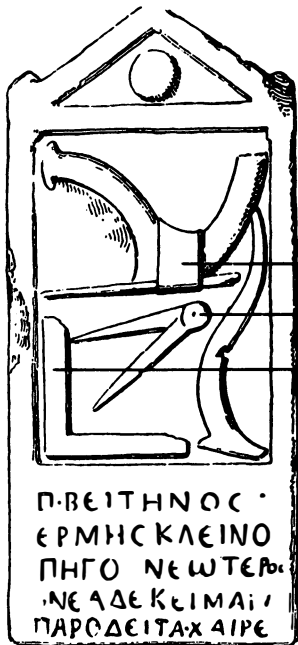

runcina
circinus
norma

in sepulcro
architecti
cuiusdam

nota –ae, f.

a) nota significat signum, ut in pecoribus, tabulis, libris, litterae singulae aut binae; apponitur rebus dignoscendi causā; synonyma: *insigne*, *vestigium*, *indicium*.

Columella, r. r. 7, 9, 12:

pice liquida notam porcis imponere.

b) speciatim dicitur de signis, quibus formantur litterae.

Cicero, Tusc. 1, 25, 62:

„qui primus sonos vocis, qui infiniti videbantur, paucis litterarum notis terminavit.“

c) item speciatim de signis, quibus utuntur, qui scribendi compendia celeritatis causā sectantur, unde postea „notarii“ dicti. notas ad compendiarie celeriterque scribendum excogitavit

M. Tullius Tiro, libertus Ciceronis et librarius, quas notas Tironias nominant; genus quoddam tachygraphiae usque ad saeculum XIV p. Ch. n. usurpatum.

Manilius, Astronom. 4, 197 ss.:

„Hic et scriptor erit velox, cui littera verbum est, Quique notis linguam superet, cursimque

loquentis

Excipiat longas nova per compendia voces.“

d) item notae (Thraeciae) dicebantur stigmata, quae inurebantur cuti. Cicero Thracum morem fuisse indicat, ut se notis compingerent. (vide imaginem!)



nundinae –arum, f. pl.

sunt mercatus seu feriae rusticorum, quibus Romam proficiscebantur negotiis domesticis provisuri.

Macrobius, 1. Saturn. 16, 34:

„Rutilus scribit Romanos instituisse nundinas, ut octo quidem diebus in agris rustici opus facerent, nono autem die, intermisso rure, ad mercatum legesque accipiendas Romam venirent ...“

verbum: nundinor 1, = mercor 1.



Apollo nimbo
praeditus



Diana cum nimbo



etiam imperatores ut dei nimbo instruuntur ut
in hac imagine imperator Valentinianus II

c) item apud Christianos nimbus dicitur radi-
antis splendoris *corona*, qua picta et sculpta
sanctorum capita decorantur.

noctua –ae, f.

noctua avis est nocturna e genere strigidum,
quae noctu vīgilat et interdiu dormit.
deae Athenae sacra erat, itaque et urbis Athe-
narum *insigne* erat noctua.



nomenclator –oris, m.

est qui memoriter unumquemque nominare
didicit.

nomenclatura –ae, f. est nomenclatio, appel-
latio, e. gr. recitatio nominum locorum, oppi-
dorum, fluminum, etc., quae in terra sunt.

norma –ae, f.

est instrumentum fabrorum duabus regulis
constans, inter se ab uno capite coagmentatis
Latinae litterae L figuram et rectum angulum
referentibus. rationem normae deformandae, a
Pythagora inventam, tradit *Vitruvius*, 9, praef. 6:
„si sumantur“, inquit, „regulae tres, e quibus
una sit pedes tres, altera pedes quattuor, tertia
pedes quinque; haeque regulae inter se compo-
sita tangat alia aliam suis cacuminibus extre-
mis, schema habentes trigoni, deformabunt
normam emendatam.“

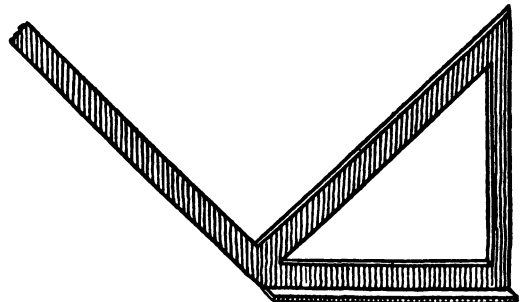

norma ex aere conflata

est pugna navalis. dicitur etiam de ludicris pugnis, quae aut arte collectā aquā, aut in stagno lacuve aliquo spectacula loco edebantur. Servius, ad Vergilii Aen. 5, 114: docet Romanos Punico bello primo naumachiam ad exercitium instituisse, postquam cognoverunt exteras gentes etiam navali certamine plurimum posse.

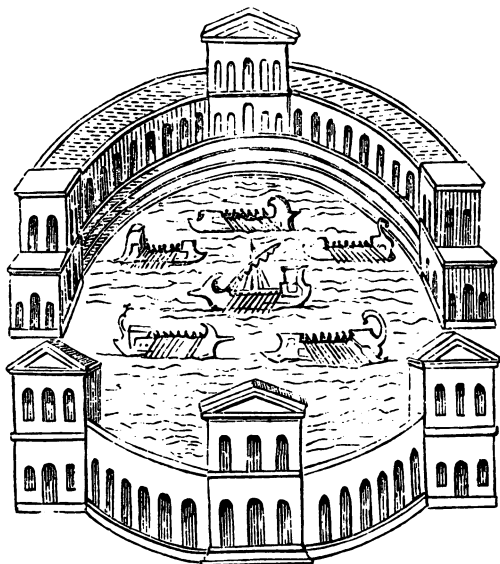

naumachia in circo (*circus*) editur spectacula loco ut describitur in nummo quodam imperatoris

navis –is, gen. plur. –ium f.

est machina e ligno, qua per mare, flumen, lacumve iter facimus. sunt plura genera navium, aliae sunt apertae, aliae tectae, seu constratae, sunt longae, onerariae, rostratae, fluviatiles, speculatoriae, actuariae, piscatoriae etc. locut.: navem appellere ad aliquem locum navem solvere (= ancoras (*ancora*) tollere)

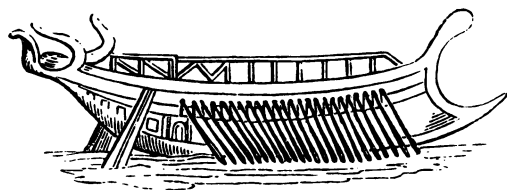

navis longa est navis in pugnis navalibus utilis, uno ordine remorum acta. navis tecta, strata aut constrata, cui navis aperta opponitur.

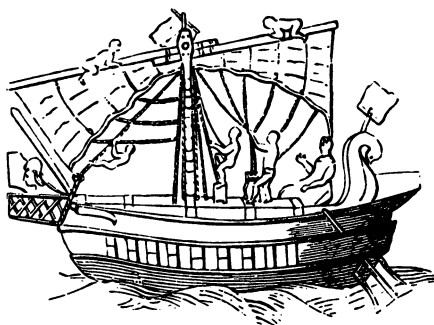

navis oneraria: navis mercatorum onera portans

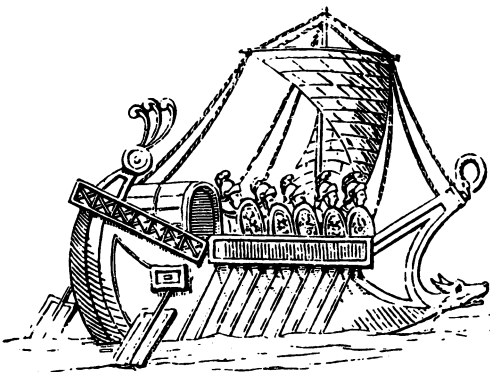

navis actuaria est navis remis et velis acta, quae in bello usurpabatur.

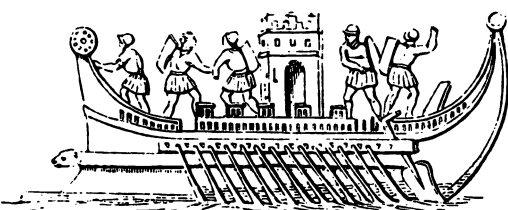

navis turrata est navis turri instructa, e qua tela in hostes proiciebantur.

proverbium: navem perforat, qua ipse navigat.

nimbus –i, m.

a) est pluvia repentina.
 b) item est nubes splendida et splendor, qui circa caput et corpus deorum esse fingitur. Servius, ad Vergilii Aen. 2, 616: „est enim fulgidum lumen, quo deorum capita cinguntur: sic etiam pingi solet.“

nassa –ae, f.

est vimine textum vas piscatoris (*piscator*),
quo cum intravit piscis, exire non iam potest.



piscatores e *scapha* nassas in aquam demittunt.
opus tessellatum in Africa Septentrionali (Sousse)
inventum

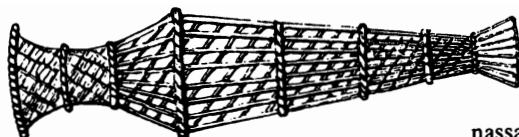

nassa

nassiterna –ae, f.

est genus vasis
aquarii ansati
et patens, quale
est quo equi
perfundi solent.
usurpatur etiam
ab hortolanis ad
plantas irrigandas.

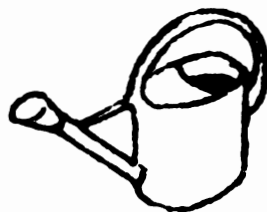

naumachia –ae, f.

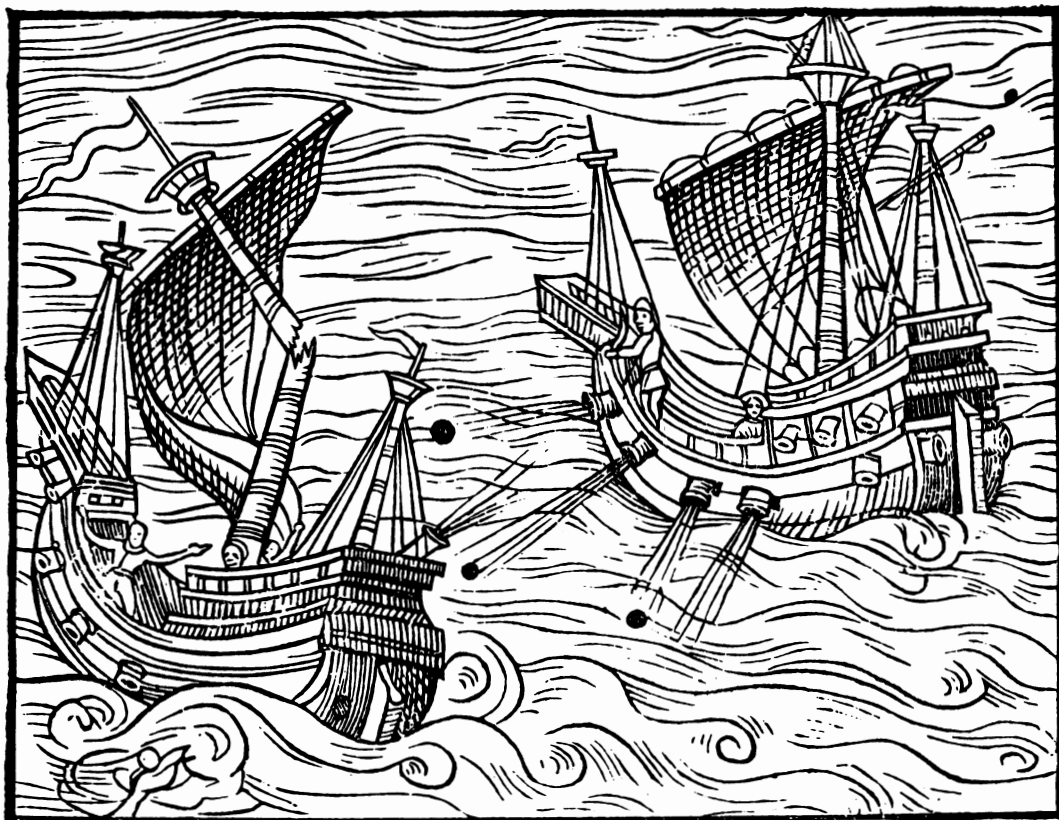

naumachia (pugna navalis) pro portibus Islandiae, describitur in opere Olai Magni

c) item tuba, qua utuntur *Tritones*, quae et concha appellatur.

d) murex ferreus est instrumentum ferreis instructum cuspidibus, tetragona forma, quod in quamcumque partem inciderit, aculeos protendit; in terram dolose conici solet, ut iis hostilis equitatus ingruens induatur.

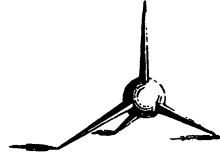

murex ferreus

Musae –arum, f. pl.

Musae sunt deae, filiae Mnemosynes (Memoriae), quae poeticae et musicae ceterisque artium liberalium disciplinis (*artes liberales*) praesunt: qua re frequentissime eas invocant poetae.

Clio historiae praest, Euterpe tibiis, Thalia comoediae, Melpomene tragoediae, Terpsi-

chore lyricis cantibus, Erato carminibus amatoriis, Polyhymnia pantomimis fabulis, Urania astronomiae, Calliope epico carmini. Musae Latine etiam Camenae dicuntur. Musae choreas agunt ducente Apolline citharoedo. (*Apollō*)



muscus –i, m.

muscus est villosa illa lanugo, quae in arboribus ac saxis provenit, qualem videmus circa fontes (*fons*) et loca humida, qualis etiam est illa, quae in mari petris innascitur ac mari innatat, unde et in litus evolvitur ac proiicitur, quae aliter „alga“ dicitur.

adi. muscosus, –a, –um = musco abundans, musco obsitus: muscosi fontes.



muscus hepatica



muscus

a) fuit cognomen Iunonis, quia Romanos monuisse credita est, ut propter terrae motum suae plena rem divinam facerent (Cicero, Div. 1, 45, 101).

b) moneta est templum, sive locus, in quo pecunia cuditur.

monetarius

est is, qui monetam cudit, qui in moneta publica operatur. huiusmodi artificum corpus quoddam Romae fuit.

Monumentum Ancyranum

est inscriptio (*titulus*) Caesaris Augusti, cuius exemplar Ancyrae (hodie Ankara) repertum est in templo Augusto consecrato. inscriptio in tabulis indicat res ab Augusto gestas. („Res gestae Divi Augusti“) veri simile est has tabulas paulo post mortem Augusti exaratas esse et verba ipsius imperatoris continere. alibi in Imperio Romano multae tabulae eiusdem generis exstistisse dicuntur. hoc est initium inscriptionis: „annos undeviginti natus exercitum privato consilio et privatā impensā comparavi, per quam rem publicam a dominatione factionis oppressam in libertatem vindicavi ...“

mortarium –i, n.

est vas, in quo res, quae resolvendae sunt, pistillo (*pistillum*), vecte, aut manibus teruntur subigunturve. materia mortarii est marmor, lignum, testa, aes, aliaque.

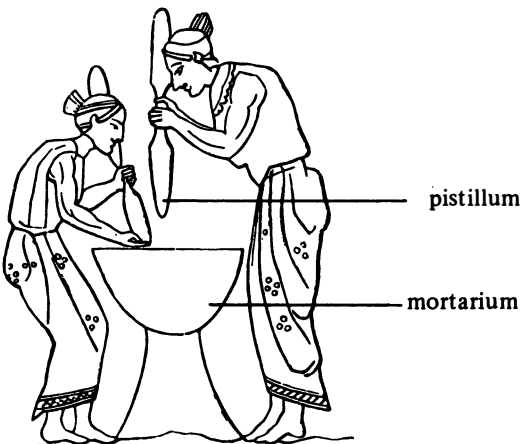

Cato, r. r. 74:

„farinam in mortarium indito, aquae paulatim addito, subigitoque pulcre.“

Columella, r. r. 12, 57, 1:

„semen sinapis ... duabus horis in aqua sinito, postea tollito, et manibus expressum in mortarium novum conii cito, et pistillis conterito.“

mulctrum –i, n. (vel mulctra –ae, f.)

mulctrum est vas in quo lac mulgetur.

Calpurnius, Ecl. 4, 25:

„duc ad mulctra greges.“

verbum: mulgeo, mulsi, mulctum, mulgēre.

proverbialiter: „hircos mulgēre“, aliquid conari, quod fieri nullo modo potest.



murex –icis, m.

a) murex est molluscum ex genere concharum, qui et bucinum dicitur. ex eius suco olim color purpureus fiebat; unde et pro purpura et pro ipso colore accipitur.

b) speciatim est testa huius animalis; concha murex dicitur, qua oleum, unguentum etc. servatur.



Triton murice canens

mola –ae, f.

mola est machina, qua molinarij utuntur ad molendum (molo, –ui, –itum, –ere) frumentum.

erant molae hominum aut bestiarum vi actae, vel molae aquariae, quae impetu fluminis versabantur. molae ventorum vi actae primae in Europa inveniuntur saeculo nono p. Chr. n. in Britannia.

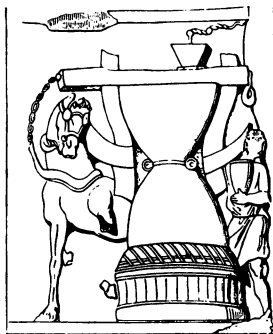

mola equo acta, ex opere caelato in Museo Chiaramonti, Romae, exposito

mola aquaria vi fluminis agitur. nam rota pinnis instruitur, quae, cum percutiuntur impetu fluminis, cogunt versari rotam. huius, ut explicat Vitruvius 10, 5, 2: „in uno capite axis (2) tympantum dentatum (3) est inclusum. id autem ad perpendicularum conlocatum in

cultrum versatur cum rota (1) pariter. secundum id tympantum maius item dentatum (4) planum est conlocatum, quo continetur. ita dentes tympanti eius (3), quod est in axe (2) inclusum, impellendo dentes tympanti plani (4) cogunt fieri molarum (5) circinationem. in qua machina impendens infundibulum (6) subministrat molis frumentum et eadem versatione subigitur farina.”

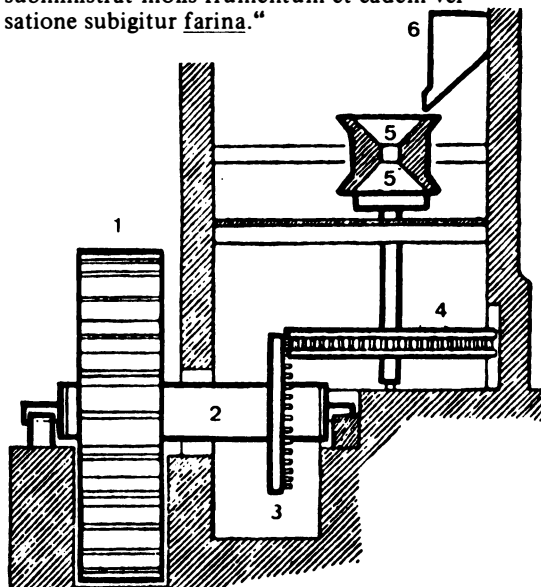

Moneta –ae, f.



monetarii in officina, ex Olai Magni opere

minio –as, –atum, –are / **miniatura, –ae, f.

miniare est minio tingere. cera miniata vel miniatula, erat cera rubra, qua notabant, quae minus probarent et corrigi vellent. Cicero, ad Atticum 15, 14, 4: „quae quidem (litterae) vereor, ne miniata

cerula tua pluribus locis notandae sint.“
**miniatura, –ae, f. dicitur delineamentum minio (= rubro colore) in codicibus Medii Aevi praescriptum, quod postea variis coloribus ornatur.

Mithraeum –i, n.

est spelunca vel *camera* subterranea, in qua sacra Mithrae fiebant. Mithra (–ae, m.) autem erat apud Persas idem habitus ac sol. eius mystae septem gradibus (gradus) initi-

ationem perfecerunt, ut in imagine Ostiae reperta videtur, in qua scala septem graduum initiationis monstratur.

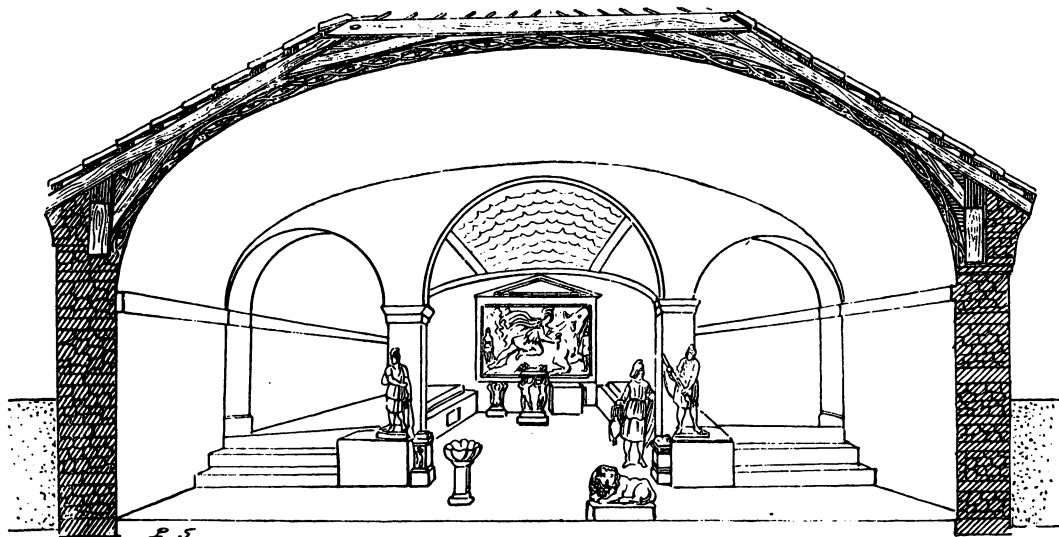

Mithraeum Carnunti repertum (reconstructio)

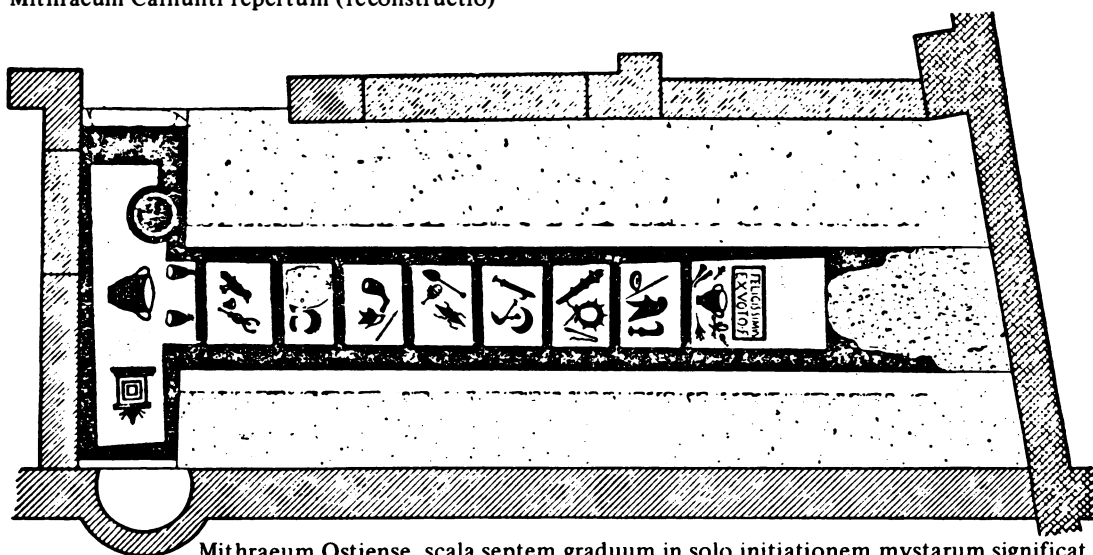

Mithraeum Ostiense. scala septem graduum in solo initiationem mystarum significat.

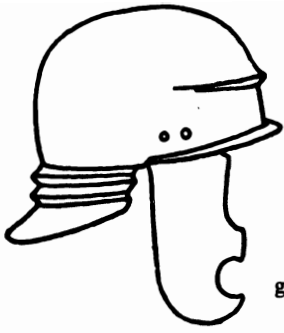

galea

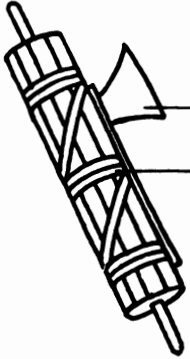

securis

fascis

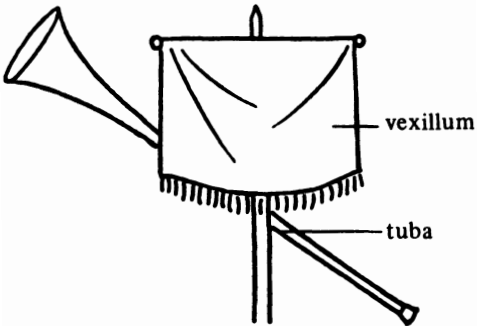

vexillum

tuba



cornu

cornicen

miliarium -i, n.

est columella seu lapis erectus in viis, praesertim militaribus, inscriptas habent notas, quibus milia quaeque passuum significantur. Hos lapides miliarios omnium primum in viis posuisse C. Gracchum narrant. miliarium aureum appellata fuit columna ab Augusto in capite Romani fori prope aedem Saturni statuta, in qua omnes viae ab urbe Roma in Italiae provincias ferentes descriptae fuerunt.

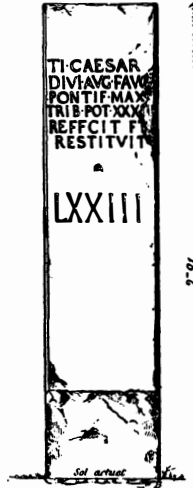

miliarium Tiberii

mimus -i, m.

mimus est gesticulator, imitator factorum dictorumque ac morum alienorum, colligendi risus causā, in scaena vel extra (a verbo Graeco mimeisthai = imitari).



miles Romanus

vestimenta, arma, insignia:

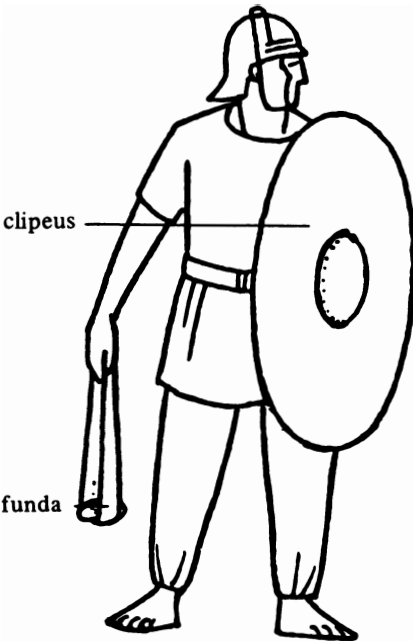
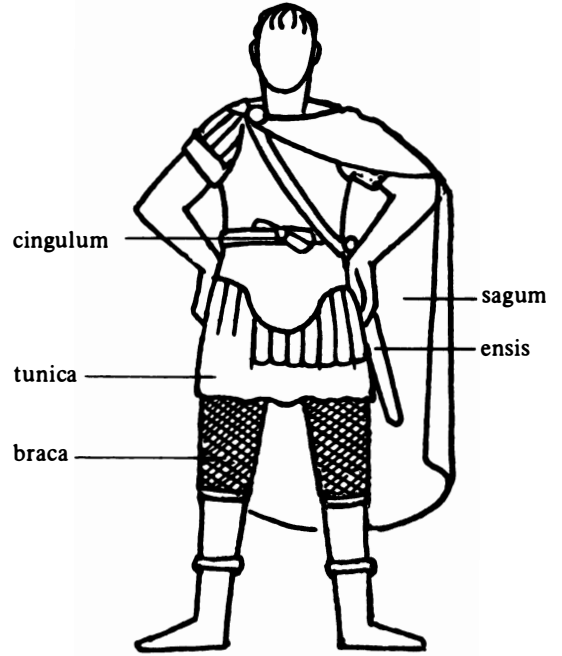
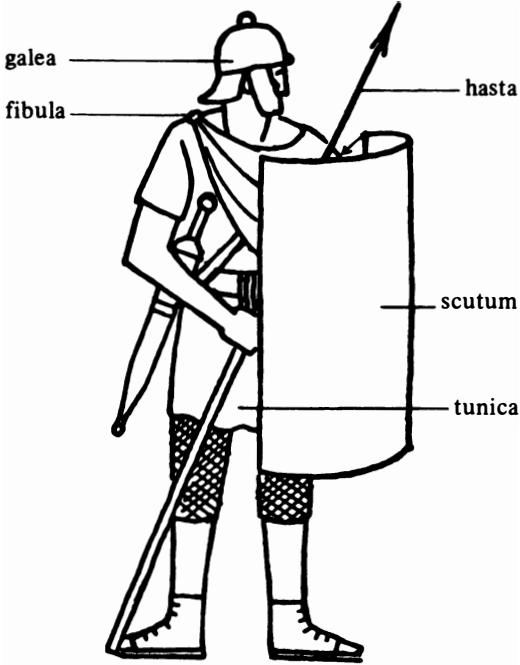

funditor

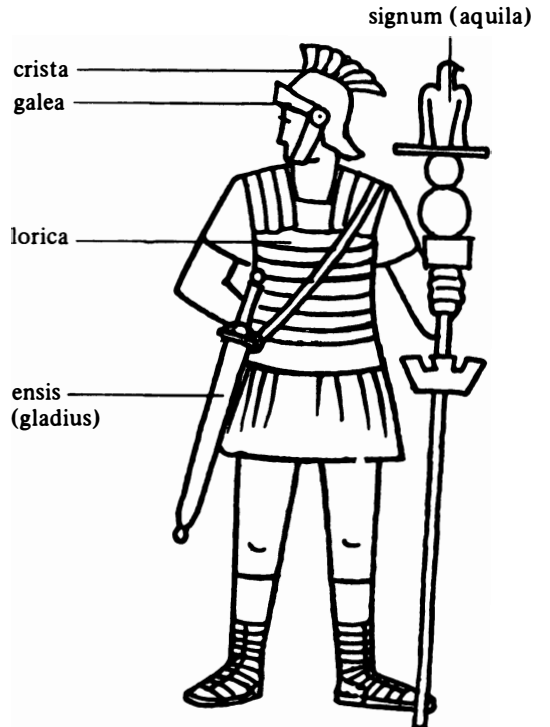

signifer (aquilifer)

messis –is, f. (acc. –em/–im)

messis est actus metendi vel secandi, speciatim est collectio frumenti et aliarum segetum.

messor est is, qui metit.

Ovidius, Heroid. 16, 263:

„sed nimium properas; et adhuc tua messis in herba est.“



figura in vase Graeco: duo Cupidines, qui digitis micant.

mum auri ramentum, ut quae in harena refulgent.

Caelius Aurelius, Tard. 1, 4:

„item velut scintillarum micas, aut circulos igneos circumferri prae oculis sentiunt aegrotantes.“

micare

significat tremulum esse, corruscare, crebro celerique motu agitari, subsilire, vibrari, concuti.

Ovidius, Fasti 3, 36:

„terreor admonitu: corda timore micant.“

speciatim: **digitis micare** est digitis sortiri: cum porrectis invicem crebro digitis, certantium uterque numerum eorum divinat.

Cicero, de div. 2, 41, 85:

„quid enim sors est? idem propemodum, quod micare, quod talos iacere, quod tesseras.“

proverbium: cum alicuius fidem bonitatemque laudant rustici homines, proverbio dicunt, „dignum esse, quicum in tenebris mices.“

mica –ae, f.

est **frustulum** alicuius rei, v. gr. mica panis, item minutum granum salis, turis, item minutissi-

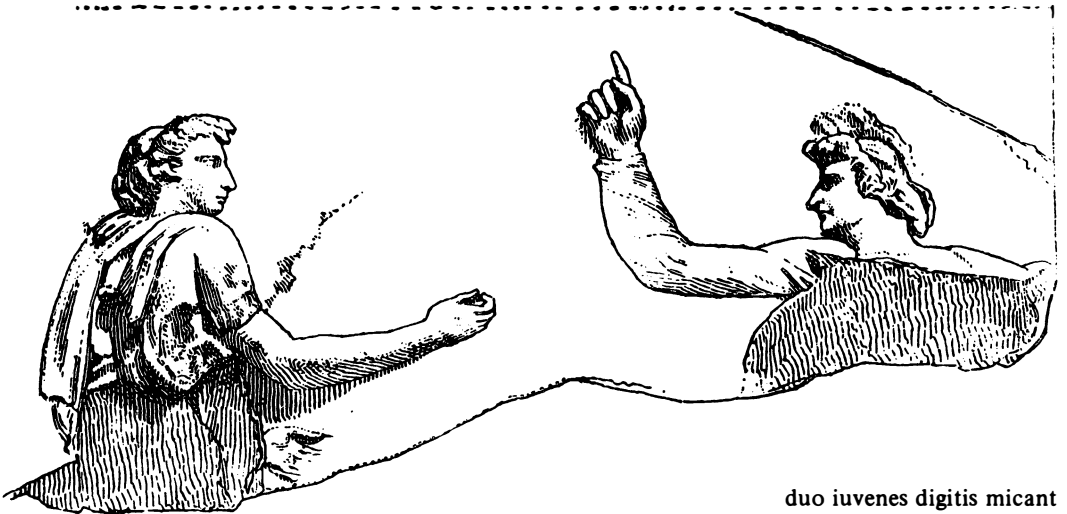

duo iuvenes digitis micant

a) sepulcrum regis Asiae, Mausoli, quod inter septem mirabilia mundi numerabatur.

b) monumentum sepulcrale sumptuosum, ut sepulcrum Augusti aut Hadriani imperatoris. Mausoleum Hadriani quod hodie Arx Sancti Angeli nominatur. monumentum longe maius et ornatius erat Mausoleum Hadriani, ex quo unica tantum, sed immanis magnitudinis turris superest, quae Romae in castro (castellum) Sancti Angeli arcis munitissimae speciem praebet. olim hoc aedificium sublimibus undique columnis (columna) erat exornatum ut in reconstructione videtur. columnarum hodie octoginta in ecclesia S. Pauli extra muros conspicuntur. loco immanis quadrigae hodie statua Sancti Angeli posita est, quae monumento hodiernum nomen Arcis Angeli dat.

b) est instrumentum, quo quippiam metimur, seu quantitatem rei cuiuspiam deprehendimus: item ipsa quantitas, modus, magnitudo cuiusque rei.

Plinius, H. N. 7, 56, 57:

„mensuras et pondera (pondus) invenit Phidon Argius vel Palamedes.“

c) in pictura est convenientia et proportio partium.

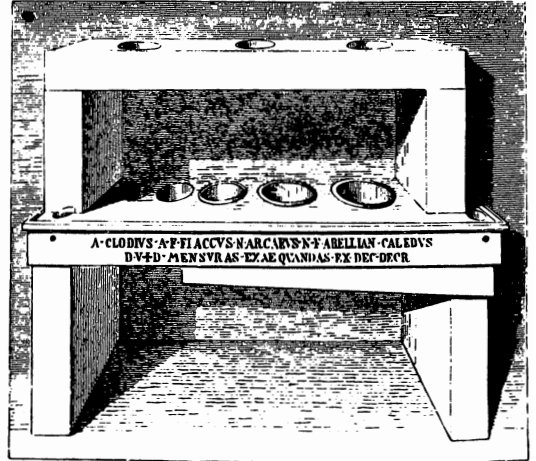

mensurae publice praescriptae

mensura —ae, f.

a) est actio, qua quippiam metimur, seu quantitatem rei cuiuspiam deprehendimus.



mensurae et pondera illustrantur in Olai Magni Historia de Gentibus Septentrionalibus

„habuit et leones et leopardos exarmatos in deliciis: quos edoctos per mansuetarios subito ad secundam et tertiam mensam iubebat accumbere, ignorantibus cunctis, quod exarmati essent.“



manumissio –onis, f.

est datio libertatis. servi cum liberarentur potestate, e manu solemnī ritu emittēbantur.

lictor servum genibus nixum vindictā (aut fistucā) tangit dicens: „hunc hominem ex iure Quiritium liberum esse volo.“

servus pileum (*pileus*), signum libertatis, sumit; nam „capere pileum“ idem est quod „libertate donari!“.

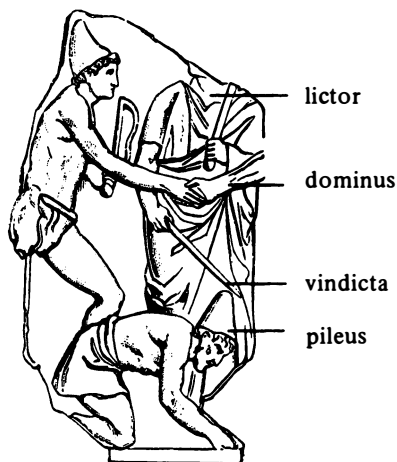

in opere caelato nostro figura domini deleta est; *lictor* in medio situs vindictam manu dextrā tenet

Mausoleum –i, n.

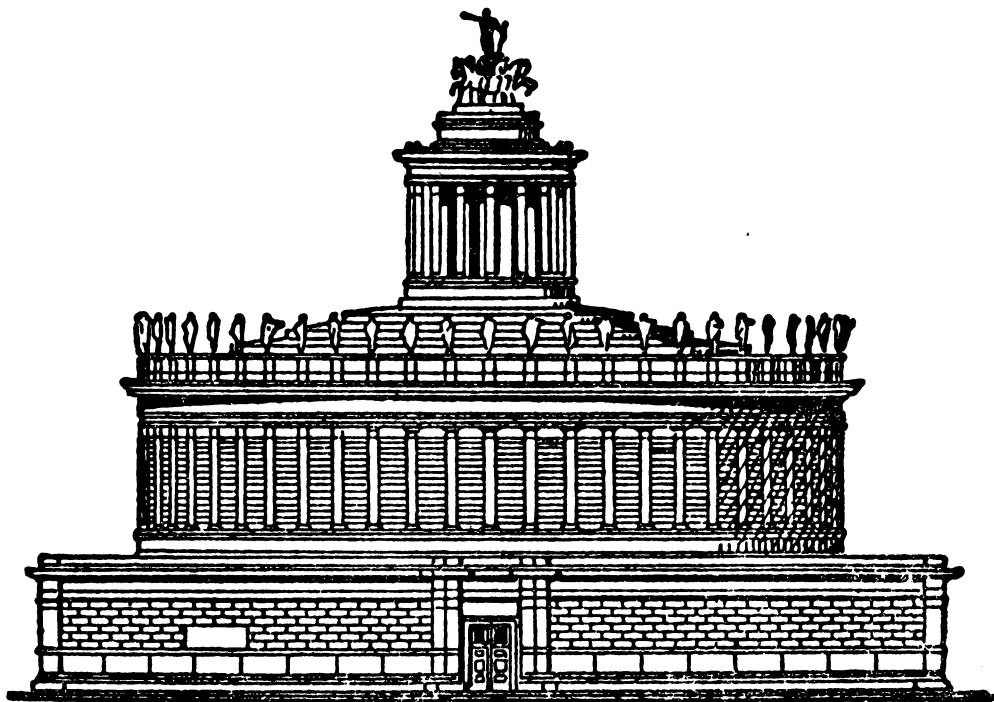

maiestas –atis, f.

est magnitudo, amplitudo, decus, dignitas deorum, populi dominatoris vel senatus, vel principis imperatorisve, aut etiam privati magni viri; ob quam honos illi et reverentia debetur.

****maiestas domini** nominatur ea imago Christi, qua in solio aut in arcu (*arcus*) Iridis supra mundum sedet tamquam rex universitatis; corpus eius soliumque nimbo (*nimbus*) circumdatum est; in quattuor angulis symbola (*symbolum*) evangelistarum, quattuor elementa aut quattuor venti eum comitantur.



maiestas Domini e codice Medii Aevi

malleus –i, m.

malleus est fabrile instrumentum ad tundendum.

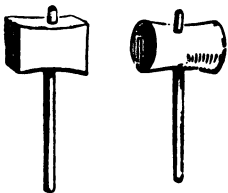

manica –ae, f. (vel manicae –arum)

a) manica est pars vestis, qua bracchia et manus teguntur.

b) manicae sunt vincula, quibus manus ligantur, sicut pedicae, quibus pedes ligantur. (*compedes*)

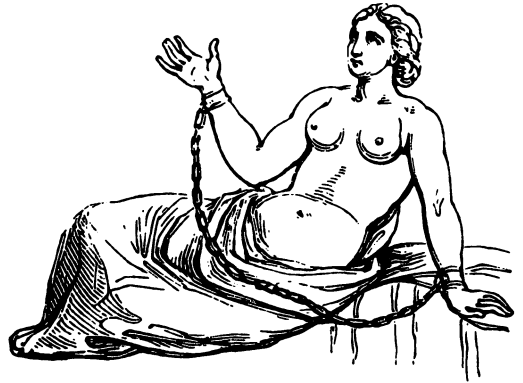

manipulus –i, m.

Isidorus, Orig. 18, 3, 5: manipulus est „manualis herbarum fasciculus, quem manu quis apprehendit metendo.“

Vergilius, Georg. 3, 297/298:

„filicumque maniplis sternere humum.“

in re militari manipulus erat exiguum peditum agmen, quod unum *signum* sequebatur.

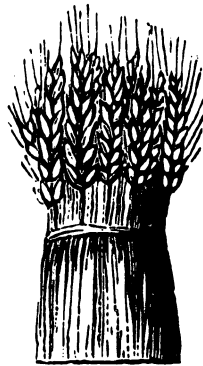

mansuetarius –i, m.

mansuetarius est qui feras cicurat et mansuetas reddit; domitor ferarum. Historia Augusta 17, 21:

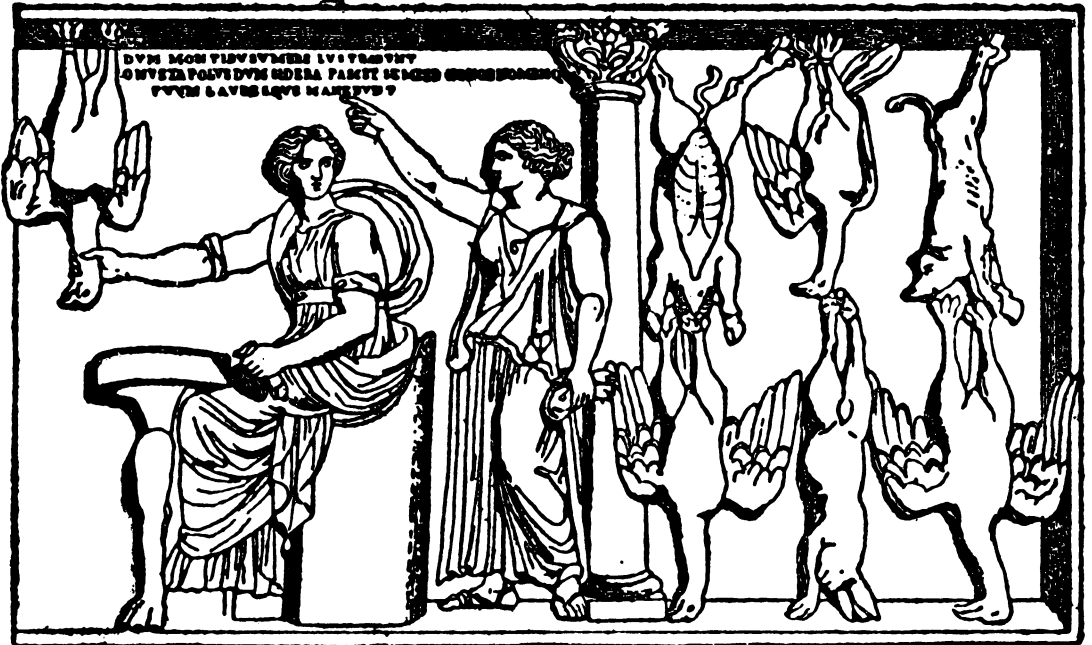

est locus, ubi macellarius carnes qualescumque coquit et vendit.
 in opere caelato sarcophagi (*sarcophagus*), qui Romae in Musaeo Torloniano monstratur, est *taberna* macellaria, ubi in pariete (*paries*)

lepores, anseres, vulpes aliaeque bestiae pendent. saepe in macello etiam coqui diebus festis conducebantur ut domi cenas maximas pararent, sicut in Aulularia Plautina.

Maeandrus est fluvius ingens Asiae in Phrygia Magna, crebris ita sinuosus flexibus, ut saepe credatur reverti.

etiam opus penicillo (penicillus) aut acu (*acus*) factum ad similitudinem Maeandri, flexuoso et in se remeabili gyro descriptum.

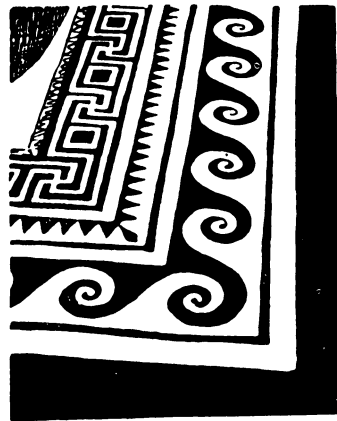
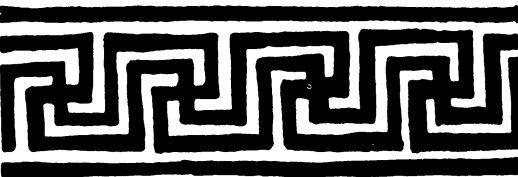
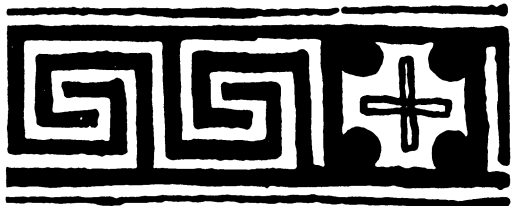

phases lunae

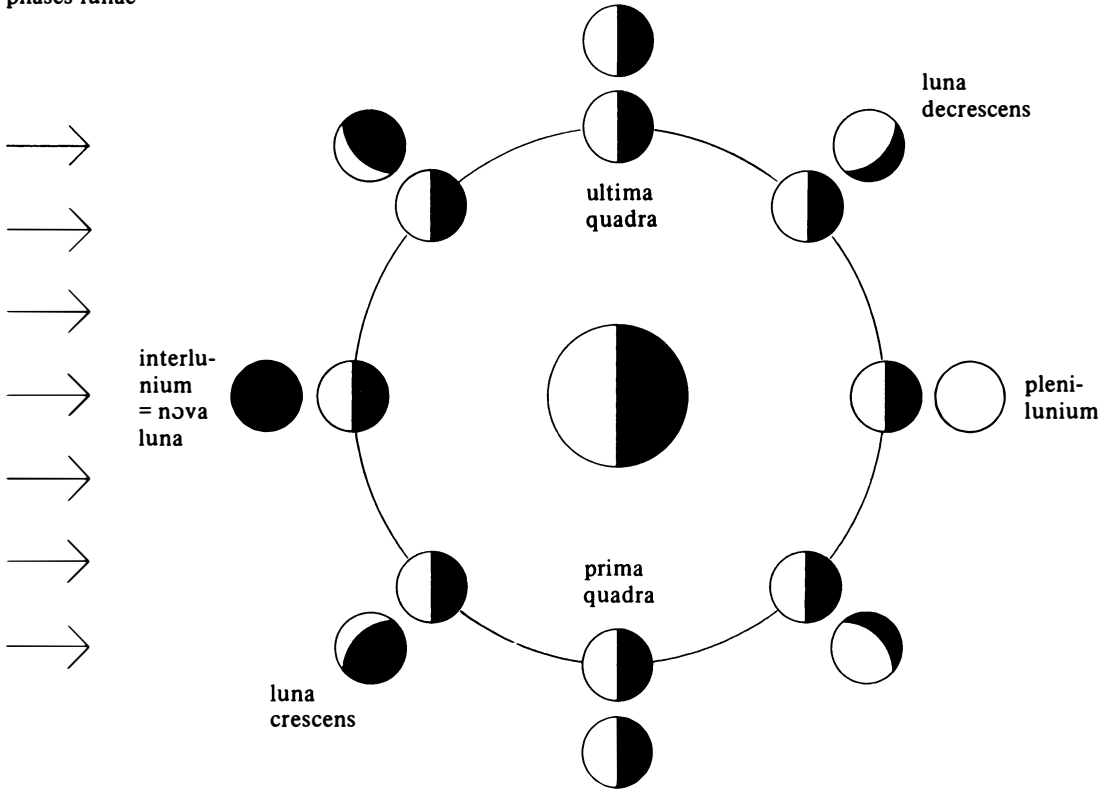

b) a similitudine litui auguralis est genus tubae minoris, incurvum, acutum edens sonum, quo in bello utebantur. (*instrumenta musica*)
Lucanus, 1, 237:
 „stridor lituum clangorque tubarum.“

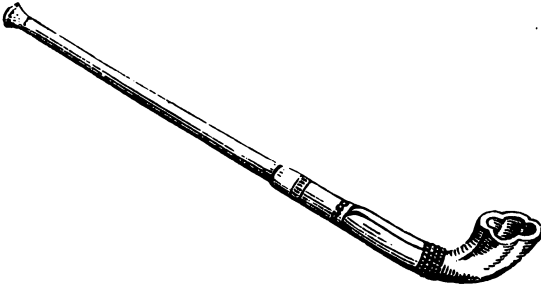

locus adverbia loci

ubi? ○
 quo? →
 unde? ←-----

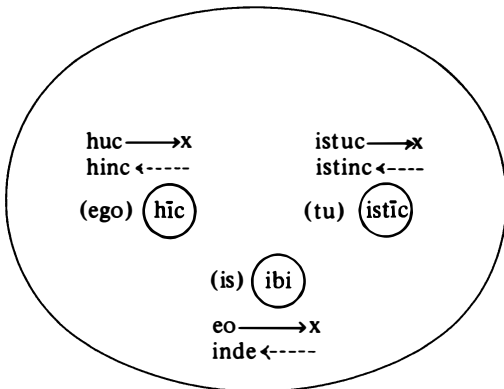

(ille) illic
 illuc → x
 illinc ←-----

ellipsis communicationis duos focos habet: ego et tu. res, de qua loquimur, aut in ellipsi (is, ea, id) aut extra ellipsim (ille, illa, illud) sita est. omnes res, quas demonstramus, ad unam harum positionum referuntur, sed etiam rerum motūs. (*quorsum*)

lucerna –ae, f.

e materiā fictili aut ex aere facta, oleo impleta est, unum, duo aut plura ellychnia habet.
lucerna pensilis catenā sustenta e tecto pendet.

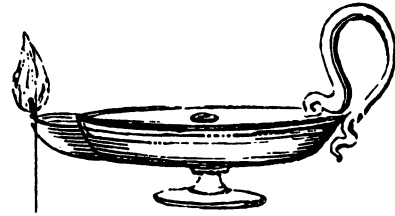

ellychnium

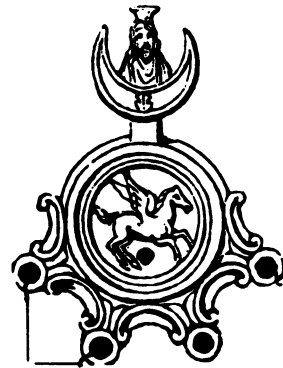

ellychnium

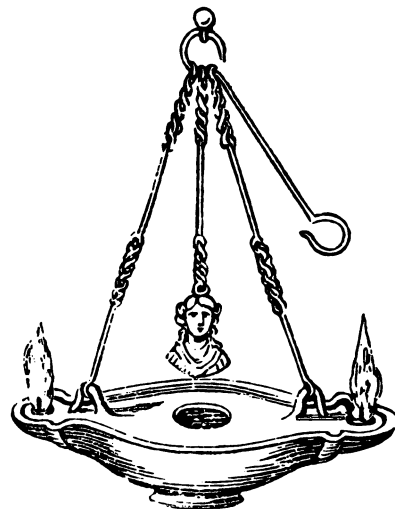

lucerna pensilis

itineris et laboris causā pervii essent. limitibus agrorum fines distinguuntur. limites etiam dicuntur Romanorum aggeres munitionesque ad Rhenum et ad Danuvium.

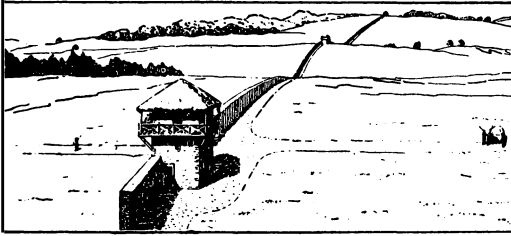

limes Rhaeticus

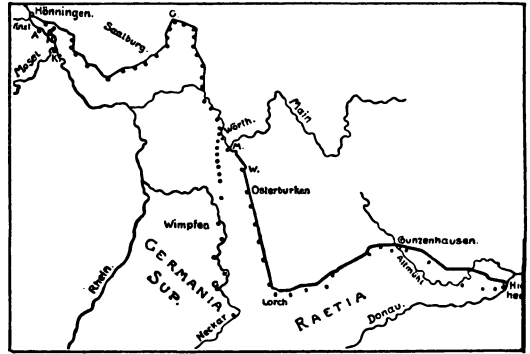

limes Romanus in Germania Superiore et in Raetia

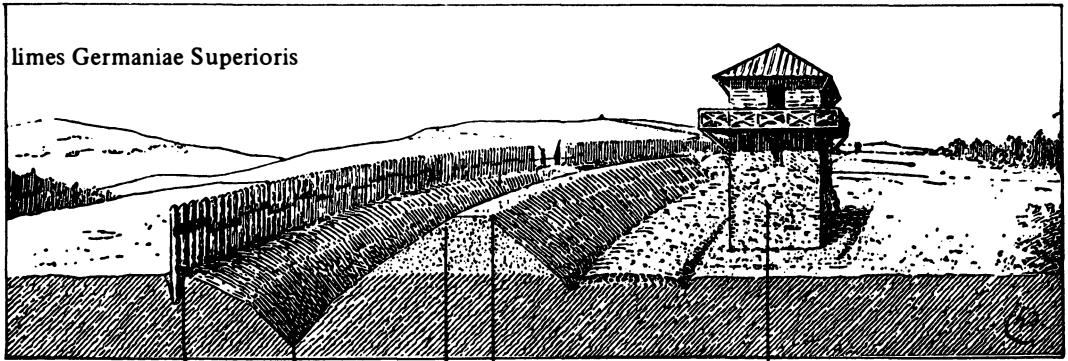

limes Germaniae Superioris

vallum fossa agger cum limite turris

litus –oris, n.

litus est terra adiacens mari, quae fluctibus alluitur; dicitur etiam de terra litori vicina.

Catullus, 71, 4:

„litus tunditur undā.“

proverbium: „in litus arenas fundere“, idem significat quod „ligna in silvam gerere.“
(*paeninsula*)

lituus –i, m.

a) lituus est baculus incurvus, quo augures sedentes avibus templum designabant.

Livius, 1, 18, 7:

„dextra manu baculum sine nodo aduncum tenens, quem lituum appellaverunt.“

**similis lituo est nunc episcoporum baculus.

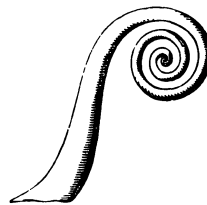

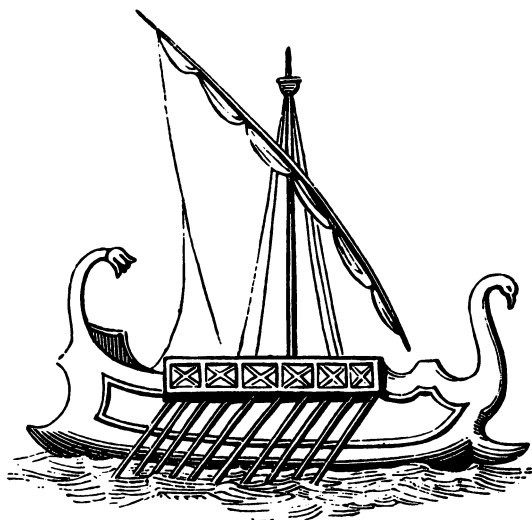

lictor –oris, m.

fascem (**fascis**) virgarum ligatum fert. lictores consules et praetores comitantur; numero lictorum et fascium eorum potestas indicatur. fascis **securis** est **virgis** conligatis circumdata (*miles Romanus*).



ligo –onis, m.

ligo est instrumentum rusticum lato ferro, herbis ac radicibus evellendis, purgandoque agro et terrae fodiendae aptum.



lima –ae, f.

est instrumentum fabrile, densis minutisque dentibus, quo ferrum aliudve quid terendo exolitur.

limare: perpolire, expolire, perficere, eliminare, ad perfectum unguem castigare; limae labor: offendit poetas limae labor (Horatius).



limen –inis, n.

est lignum aut lapis transversus in ianua aut porta, tum superius tum inferius. religiosum erat limen aedium, quod propterea abeuntes redeuntesque salutare solebant:

Plautus, Mercator 830:

„limen superum inferumque, salve ...“

limes –itis, m.

est semita transversa, tum in agris, tum in uribus, sed stricto sensu in agris. his limitibus agri divisi erant, ut et mensurae et

c) volumen huius folii = liber

antiquis temporibus folia perlonga manu scripta formā voluminum in capsis aut armariis conservabantur. ut legi possent, volumina duabus manibus evolvebantur ut imago in sarcophago quodam exsculpta demonstrat.

ultimis temporibus Imperii Romani, aetate iam Christiana, textūs foliis in forma codicum colligatis manu inscribebantur, ut in scriptorio hoc patris cuiusdam ecclesiastici videmus:



in pluteis armarii varii codices sunt. vir in scamno sedens pennā atramento tinctā scribit. ante armarium utensilia scribendi delineandique sunt: stilus, circinus, atramentarium aliaque. codex (caudex)

a) truncus arboris est aut massa ligni. (codicillus)

b) summa tabellarum cerā illitarum formam codicis praebebat et codex nominabatur.

c) folia chartarum eodem modo colligata codex nominabantur, liber crassus et magni ponderis. multi librarii in eodem conclavi sedentes textum a lectore recitatum propria manu scribebant. sic orationes Ciceronis et alia opera in scriptorio Attici, amici eius, multiplicati et postea magno pretio divulgati sunt. etiam in monasteriis prioris Medii Aevi textūs describebantur et sic in posterum conservati sunt.

libra –ae, f.

instrumentum est quo ad pendenda pondera utimur.

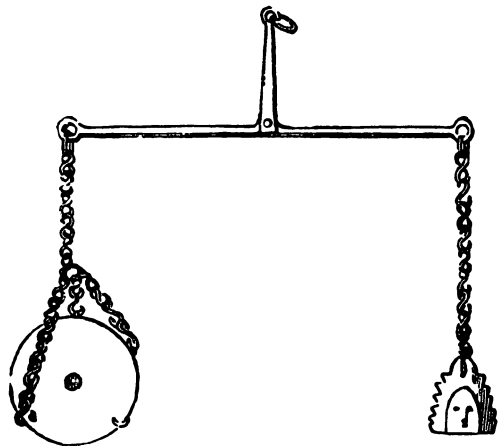

libra sine balance

iugum

aequipondium

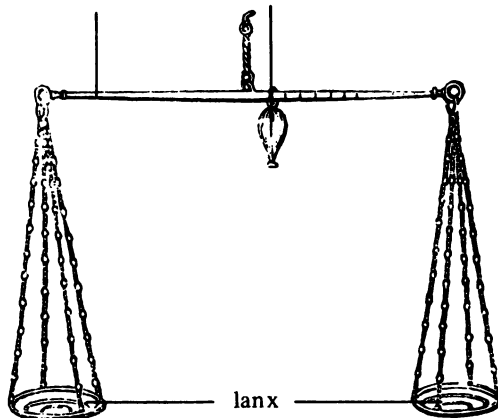

lanx

Liburnica (vel Liburna)

sc. navis. est genus navigii velocioris, variae magnitudinis, nam minima unum habebat remorum ordinem, paulo maior binos. dicta est a Liburnis, populo Illyrici, quorum auxiliis cum usus fuisset Augustus bello Actiaco contra Antonium et Cleopatram, et experimento didicisset eorum naves ceteris aptiores esse, classem Romanam ad illarum exemplum restituit et ipse et ceteri deinceps imperatores. imago sumpta est e nummo cuiusdam imperatoris.

libella –ae, f.

est instrumentum fabrile, quo utuntur ad examinandas planae superficiei inclinationes, quemadmodum *normā* angulos metiuntur, perpendicularo (*perpendicularum*) erecti operis directam aut obliquam positionem. constat autem libella duabus regulis ita iunctis

ex altera parte, ut angulum efficiant, in ima vero parte alia recta pro basi: in summo angulo filum habet plumbo pendente, ex quo inclinatio omnis deprehenditur. estque figura litterae A in imo clausae.

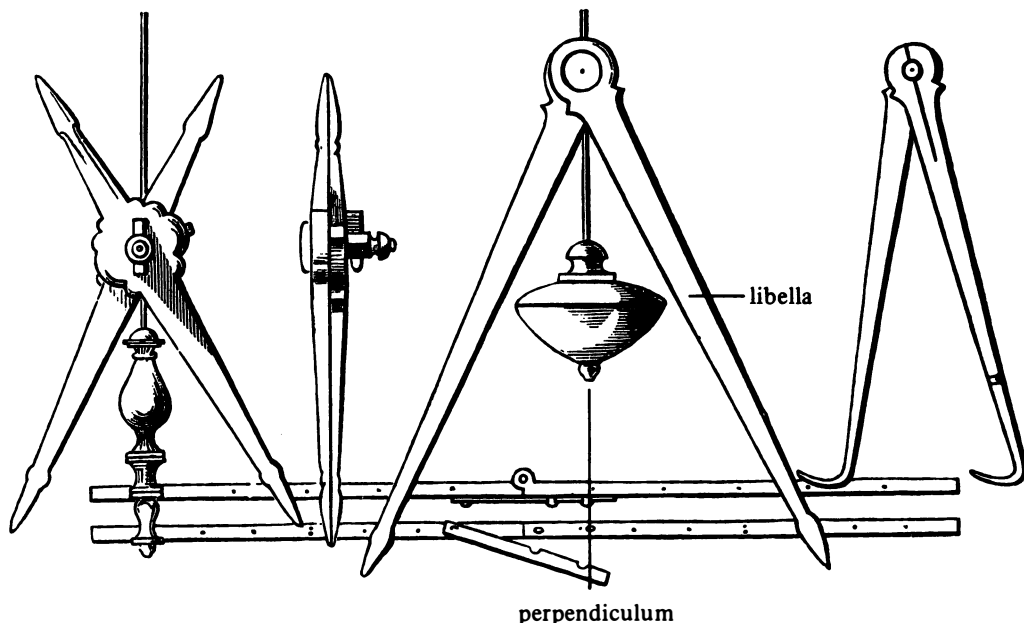

liber –bri, m.



liber est
a) interior pars corticis arbusculae, quae *papyrus* vocatur. e libro facta sunt folia, quibus facile inscribi poterat.
b) folium perlongum e libro factum

novem volumina in armario deposita

atramentarium atramenti plenum

evolvere volumen aut librum = legere librum

lectisternium —i, n.

est sacrificii genus, in quo deis in templis pulvinaria sive lecti sternebantur, conviviumque iis apponebatur.

appositis epulis septem sacerdotes, qui dicti sunt Epulones, fruebantur.

Livius, 5, 13, 6:

„duumviri sacris faciundis, lectisternio tunc primum facto, per dies octo Apollinem Latonamque et Dianam, Herculem, Mercurium atque Neptunum, tribus quam amplissime tum apparari poterat, stratis lectis placaverunt.“

idem 22, 10, 9:

„curatum lectisternium, et per triduum habitum, decemviris sacrorum curantibus: sex pulvinaria in conspectu fuere, Iovi et Iunoni unum, alterum Neptuno ac Minervae, tertium Marti et Veneri, quartum Apollini ac Dianae, quintum Vulcano ac Vestae, sextum Mercurio ac Cereri.“



lectisternium in *lucerna* fictili opere caelato sculptum; dei sunt Serapis, Isis, Luna et Sol

lectus —i, m.

et deminutivus lectulus, parvus lectus, est cubile stratum iacendi et dormiendi causā.

in lecto triclinari Romani mensae accumbebant. (*triclinium*)

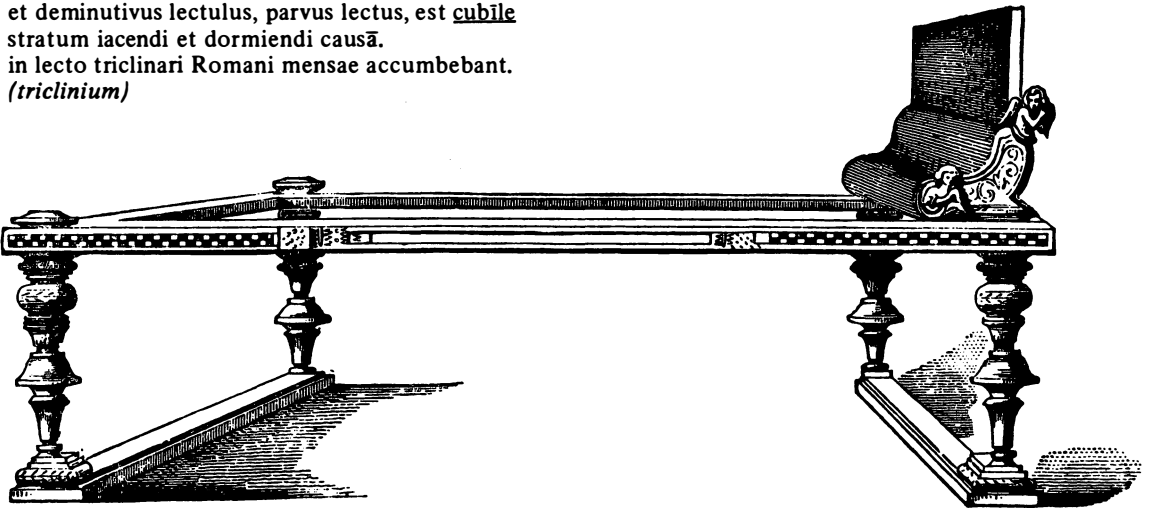

lectus aeneus, argento indutus

legenda —orum, n. pl.

legendarius liber „acta Sanctorum per anni totius circulum digesta continens, sic dictus, quia certis diebus ‚legenda‘ erant in Ecclesia.“ (Du Cange)

„Legenda Aurea“ titulus operis Iacobi a Voragine, saeculi XIII. p. Ch. n. notissimum opus huius generis est.

Latium —i, n.

est regio Italiae mediae, limites habens inter Etruriam, Umbriam, Samnium et Campaniam et mare inferum, cuius pars septentrionalis a Latinis colebatur. urbes et oppida: Roma caput orbis, Ostia, Tibur, Praeneste, Tusculum, Antium, Tarracina, Fregellae, Minturnae.

viae: Via Cassia, Via Aurelia, Via Portuensis, Via Appia, Via Latina, Via Valeria, Via Salaria, Via Flaminia.

montes: mons Albanus

flumina: Tiberis, Anio, Liris.



lectica —ae, f.

est sella cum pulvino et lectulo, qua divitiores cubantes servorum humeris vel duorum, ut tenuiores, vel quattuor aut sex aut octo, ut ditiores, ferebantur, primum quidem itineris causa extra urbem, deinde paulatim etiam in ipsa urbe, deliciarum causa.

lecticarius servus est qui lecticam defert.

pulvinus

lectulus

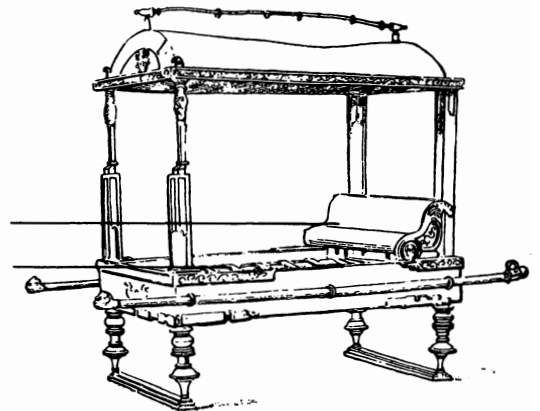

taberna –ae, f.

a) taberna est aedificium utile ad habitandum, sed speciatim est *casa* humilis et pauper.

Horatius, *carm.* 1, 4, 13/14:

„pallida mors aequo pulsat pede pauperum
tabernas
regumque turres ...“

b) latiore sensu dicitur de loco, ubi merces
venerunt et ubi *artifices* artem suam profitentur,
e. g. taberna libraria, taberna sutrina, taberna
vinaria.



tabernaculum –i, n.

tabernaculum est subitarium tectum, frondibus
aut stragulis opertum, adversus solis et aeris
iniurias: qualia sunt, quae in castris excitantur
et modo huc modo illuc transferuntur.

**in ecclesia catholica, tabernaculum est pars
altaris, ubi *calices* et ostensoria conduntur.

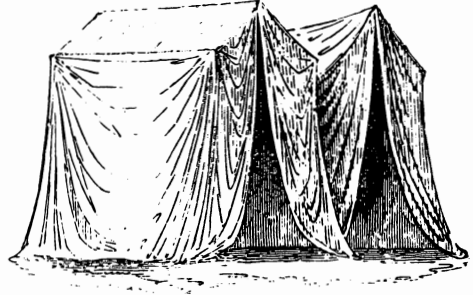

tabula –ae, f.

tabula geographica antiquis temporibus itinera
maritima aut terrestria eorumque longitudines
indicabat, ut Tabula Peutingeriana hic infra.

Conradus Peutingerius (1465 – 1547) Augustae
Vindelicorum (hodie Augsburg) vixit primus-
que antiquitates Romanas et Graecas collegit.

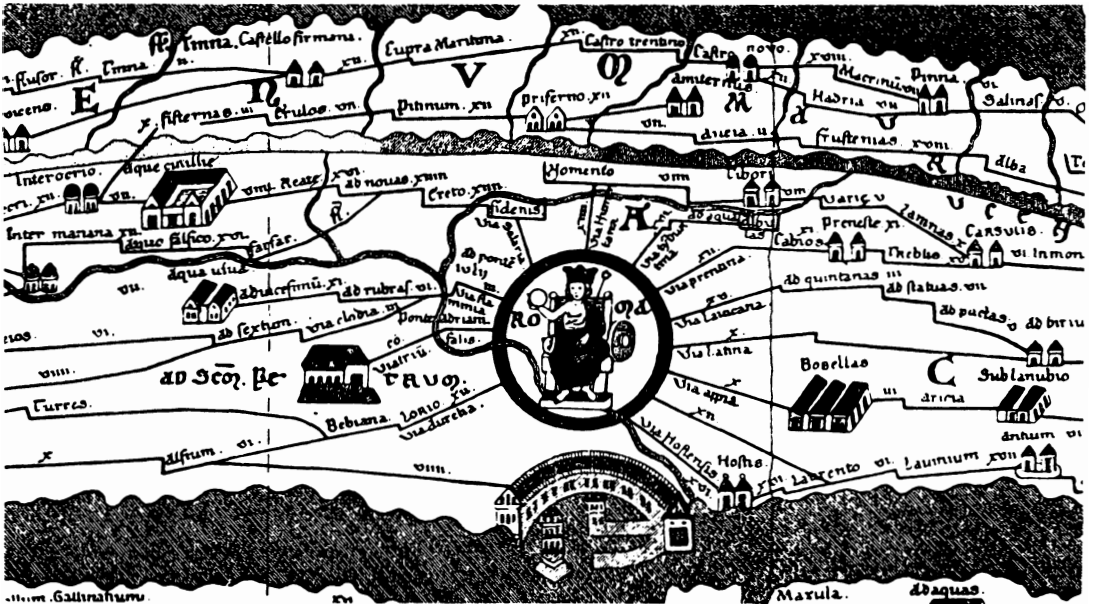

pars Tabulae Peutingerianae, quae Urbem Romam portumque (*portus*) Ostiensem cum Pharo (*pharus*) continet.

taeda –ae, f.

a) taeda est genus arboris picem ferentis, ut pinus, picea.

Plinius, H. N. 16, 11, 21:

„pax liquida in Europa e taedā coquitur navali-
bus muniendis multosque ad alios usus.“

b) taeda est assula taedae facile ardentis.

Valerius Flaccus, 2, 235:

„inicare taedas ad fastigia tectorum.“

synonymum: *fax*.

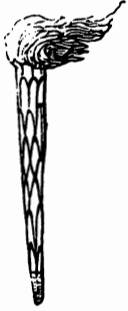

talaria –ium, n. pl.

adi. talaris, –e, ad talum pertinens.

a) talaria sunt partes pedum circa talos (*talus*).

b) talaria sunt calceamenta alata, qualia Mercurio tribuuntur.

Vergilius, Aen. 4, 239ss:

(Mercurius)

„... pedibus talaria nequit,
aurea, quae sublimem alis sive aequora supra
seu terram ... portant ...“



talio –onis, f.

est aequalis retributio, par vindicta, ita ut aliquis
talē quid patiat, quale fecit.

exempli gratia: si quis alteri oculum eruit, ipsi
quoque oculus eruat; hoc autem est:

ius (aut legem) talionis adhibere.

talpa –ae, f.

est animal muri simile, nigri coloris et ex vulgi
opinione captum oculis, quod arva et hortos
(*hortus*) suffodit.

Cicero, Acad. II, 81:

„quid? talpam num desiderare lumen putas? “

Plinius, H. N. 8, 29, 43:

„Varro auctor est, a cuniculis suffossum in His-
pania oppidum, a talpis in Thessalia.“

talus –i, m.

a) talus est in homine os in extrema tibia supra
calcem. (*calco*)

b) a similitudine est os quasi cubicae figurae in
articulo pedis multorum animalium.

his talis antiqui in ludis utebantur, sed homines
ditiores, spretis ossibus, talos ex ebore, crystallo
aliave nobiliore et pretiosiore materia factos ad-
hibebant. (*astragalus*)

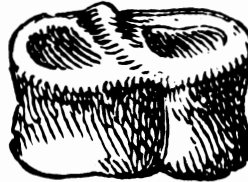

talus vel astragalus

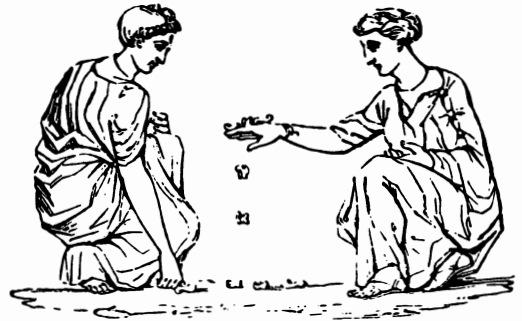

talorum ludus

tectorium –i, n.

est quidquid parieti (*paries*) exstructo vel pavi-
mento (*pavimentum*) inducitur; hinc multiplex
est genus tectorii: opus albarium, opus arena-
tum, opus marmoratum, opus testaceum.

Varro, r. r. 3, 8, 1:

parietes ac *camarae* munitae tectorio.

tegula –ae, f.

est testae (*testa*) aliusve materiae genus, quo domūs teguntur.

Plautus, Mil. glor. 504:

„quod meas confregisti imbrices et tegulas.“
imbrices rimas tegularum operiunt impediuntque, ne imber penetret inter tegulas.

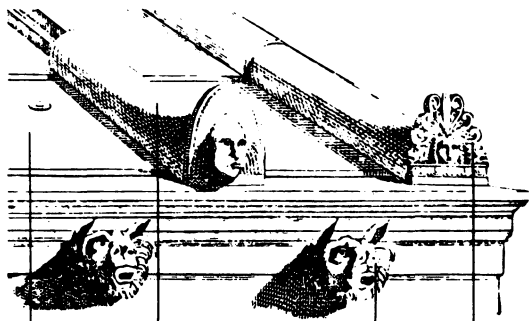

tegula imbrex stillicidium antefixum

Tellus –uris, f.

est mater terra. de qua Varro primo libro, capite primo Rerum Rusticarum haec:

„primum invocabo qui omnes fructus agriculturae caelo et terra continent, Iovem et Tellurem; itaque quod ii parentes magni dicuntur, Iuppiter pater appellatur, Tellus terra mater.“



Tellus = mater terra, opus caelatum in Ara Pacis Augusti.

temo –onis, m.

temo est lignum longum et extensum in curru vel aratro (*aratrum*), cui iugum in anteriore parte adnectitur.

Ovidius, Met. 2, 107s.:

„aureus axis erat, temo aureus, aurea summae curvatura rotae ...“

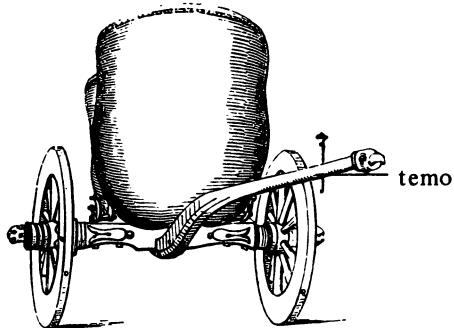

tempestas –atis, f.

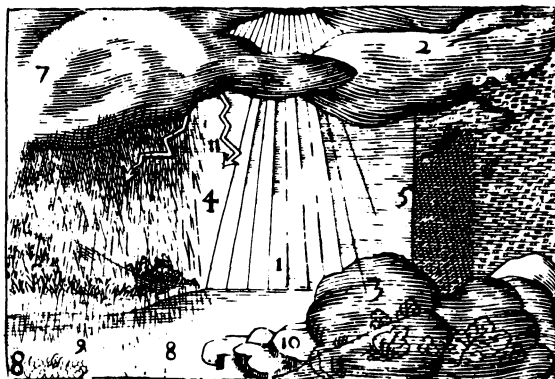

hac imagine Amos Comenius (1592–1670) in *Orbe Sensualium Picto* tempestates describit: „ex aqua ascendit vapor (1), inde fit nubes (2) et prope terram nebula (3). e nube guttatim stillat pluvia et imber (4). pluvia gelata grando (5), semigelata nix (6) est. in nube pluviosa, soli opposita, apparet Iris (7). gutta incidens in aquam, facit bullam (8), mullae bullae faciunt spumam (9). aqua congelata glacies (10), ros congelatus pruina dicitur. ex vapore sulphureo fit tonitru, quod, erumpens e nube cum fulgure (11) tonat et fulgurat.“

vapor, –oris, m.; nubes, –is, f.; imber, –bris, m.; grando, –inis, f.; nix, nivis, f.; iris, –idis, f.; glacies, –ei, f.; tonitru, –truis, n.; fulgur, –uris, n.

templum -i, n.

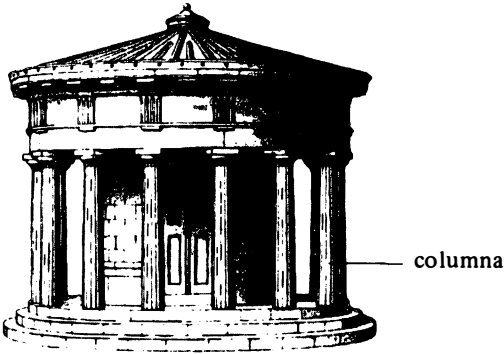

aedis rotunda (tholus) prope Delphos

a) templum est sectio, segmentum alicuius rei, vel circuitus rei a toto resectus ac definitus, vel spatium aliquod certum, praecipue auguris designatum et sacrum (*augurium*).

Isidorus, orig. 15, 4, 7:

„(templi) partes quattuor erant, antica ad ortum, postica ad occasum, sinistra ad septentrionem, dextra ad meridiem spectans; unde et quando templum construebant, orientem spectabant aequinoctialem (aequinoctium), ita ut lineae ab ortu ad occidentem missae, fierent partes caeli dextra atque sinistra aequales, ut qui consuleret ac deprecaretur, rectum aspiceret orientem.“ (*regiones caeli*)

formae templorum:

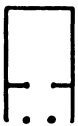

templum in antis

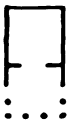

prostylos

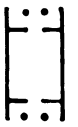

templum in antis duplex



amphiprostylos

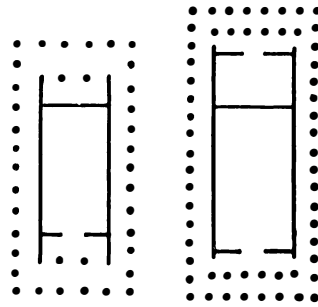

peripteros

ita templum est spatium, quod certo carmine ab augure (*augur*) lituo (*lituus*) finitum et notatum consecratumque esset, unde in omnes caeli partes liber erat aspectus.

b) „templum“ saepe etiam dicitur de aedibus, quae deis consecratae erant.

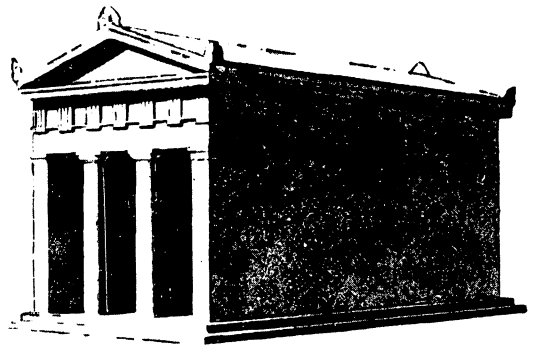

templum in antis, thesaurus Megarensium, Olympiae

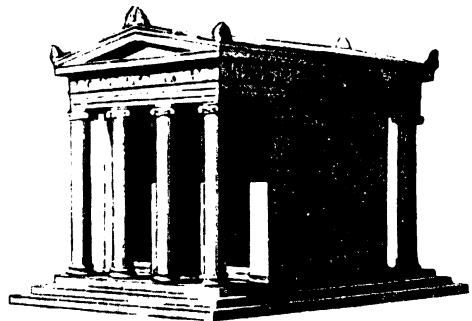

amphiprostylos, templum Victoriae (= Nices) Athenis

tensa —ae, f.

est vehiculum, quo exuviae deorum ludicris circensibus in circum (*circus*) ad pulvinar vehuntur.

tur. *tensa* est vehiculum, quo deorum *signa* atque exuviae in pompa transferuntur.



tentorium —i, n.

est *velum* funibus (funis) tensum, *papilio* extensis velis contra solem caelique iniurias excitatus; quo milites praecipue in expeditionibus uti solent. (cui opponitur *tabernaculum*, quod ligneum erat.)

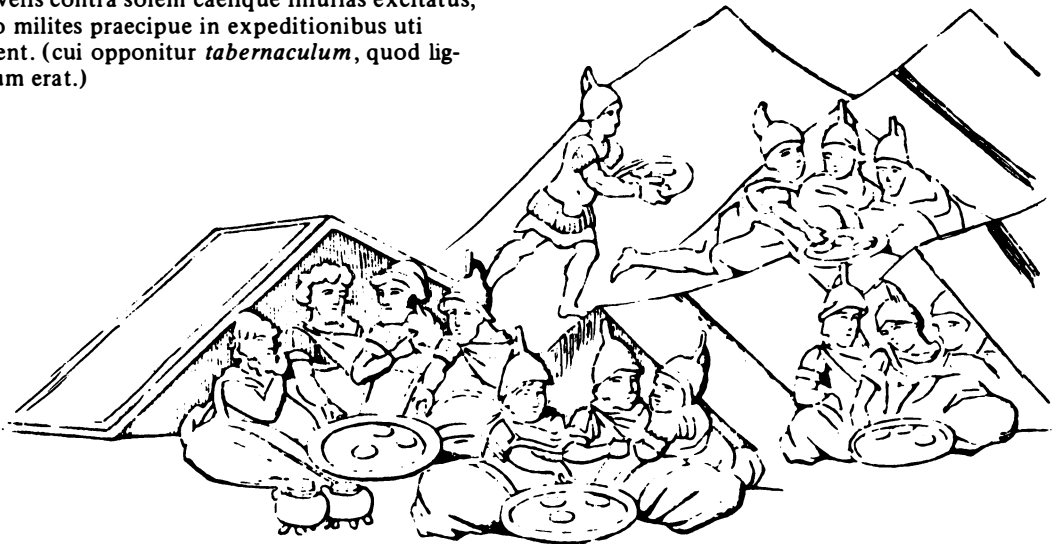

in nostra imagine e manuscripto Iliadis sumptā milites ante tentoria cubant cibumque sumunt

terebra –ae, f.

est instrumentum, quo quid, praesertim lignum, perforatur.

verbum: terebro, –are.

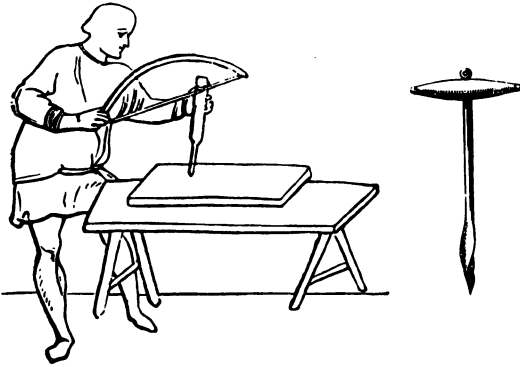

***terra sigillata –ae, f.

sigillo 1. est signo instruere, munire. sigillatus, –a, –um, est sigillis seu imaginibus ornatus. (*signum*)

Cicero, Verr. 4, 14, 32:

„iubet me scyphos sigillatos ad praetorem statim afferre.“

saepe putealia (puteal) etiam sigillata sunt. multa vasa e terra sigillata facta sunt, ex. gratia *lucernae*, ut figura demonstrat.

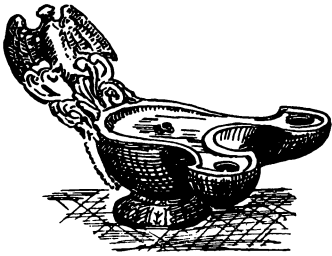

tessera –ae, f.

est id, quod figurā quadratum est, sive naturā ita factum, sive ut plurimum, arte, constans sex lateribus.

tribus dimensionibus impletis fit corpus solidum, qualis est tessera, quae cubus vocatur.

a) tesserae, dem. tesserae, vel tessellae, e quibus opus tessellatum perficitur in pavimentis (*pavimentum*) aedificiorum.

b) tesserae lusoriae sunt cubi ossei vel lignei punctis distincti, quibus in alveolum iactis luditur.

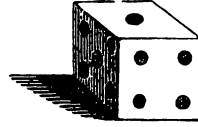

tessera lusoria (*cubus*)

c) tessera hospitalis est *symbolum* amicitiae vel coniunctionis.



d) tessera frumentaria indicat numerum congiariorum (*congius*), quem quisque in congiario (*congiarium*) recipit.

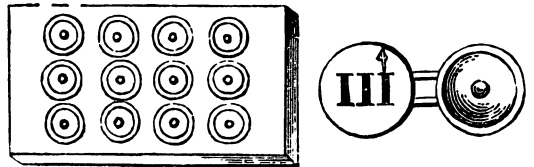

e) ***hodie tesserae tramitis, theatri, vestiarii aliarumque rerum in usu sunt.

testa –ae, f.

est *terra* vel argilla cocta vel aliquid ex terra cocta in formam aliquam compositum: hinc est nomen generale cuiuscumque vasis fictilis cocti, ut vasa escaria et vinaria, *lucernae*, urceoli, calices (*calix*), etc.

proverbium apud Horatium, ep. 1, 2, 69/70:

„quo semel est imbuta recens, servabit odorem testa diu ...“

translate etiam dicebatur de cranio, hinc „testa“ Italarum, „tête“ Francogallicorum.



testa

testudo –inis, f.

a) testudo est animal ex genere amphibiorum, testā coniectum, quadrupes, tardigradum, capite brevi, cervice anguinā.

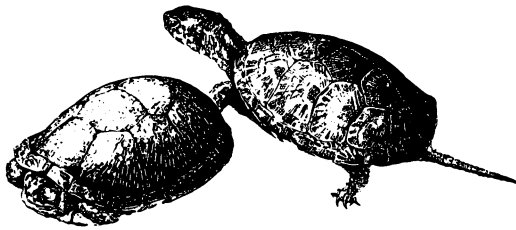

b) testudo dicitur etiam de instrumento musico, in quo fides extenduntur, cithara, barbiton et alia. (*instrumenta musica*)

c) in re militari testudo est, cum conglobati milites et scuta scutis arcte iungentes, invicem se protegent et ingruentia tela defendunt.

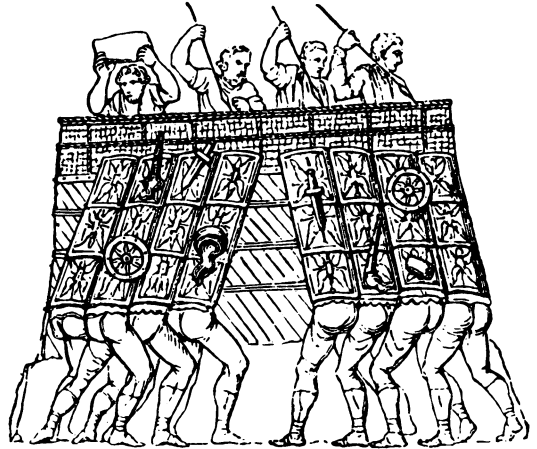

testudo militaris

textor –oris, m. / **textrix**, –icis, f.

textor est is, qui pannos texit. texere est filum filo conserendo telam conficere.

textum, –i, n. est vestis texta, pannus et quodcumque opus textum.

textus, –ūs, m. est ratio texendi, textura. translate refertur ad contextum orationis.

Ammianus, 15, 7, 6:

„(rem) brevi textu percurram.“



radius

theatrum -ī, n.

est aedificium semicirculi specie ad spectandos ludos scaenicos factum. primo stantes aderant spectaculis, crescente luxu theatra facta sunt, ut a sedentibus spectaretur. primo lignea fuerunt et temporaria, quae peractis ludis solverentur;

postea ex lapide structo et mansura. in his erant scaena, ubi actores agebant; orchestra, ubi edebantur saltationes, gradūs (cuneatim divisi) in cavea, ubi sedebant spectatores. (*cuneus, amphitheatrum*)

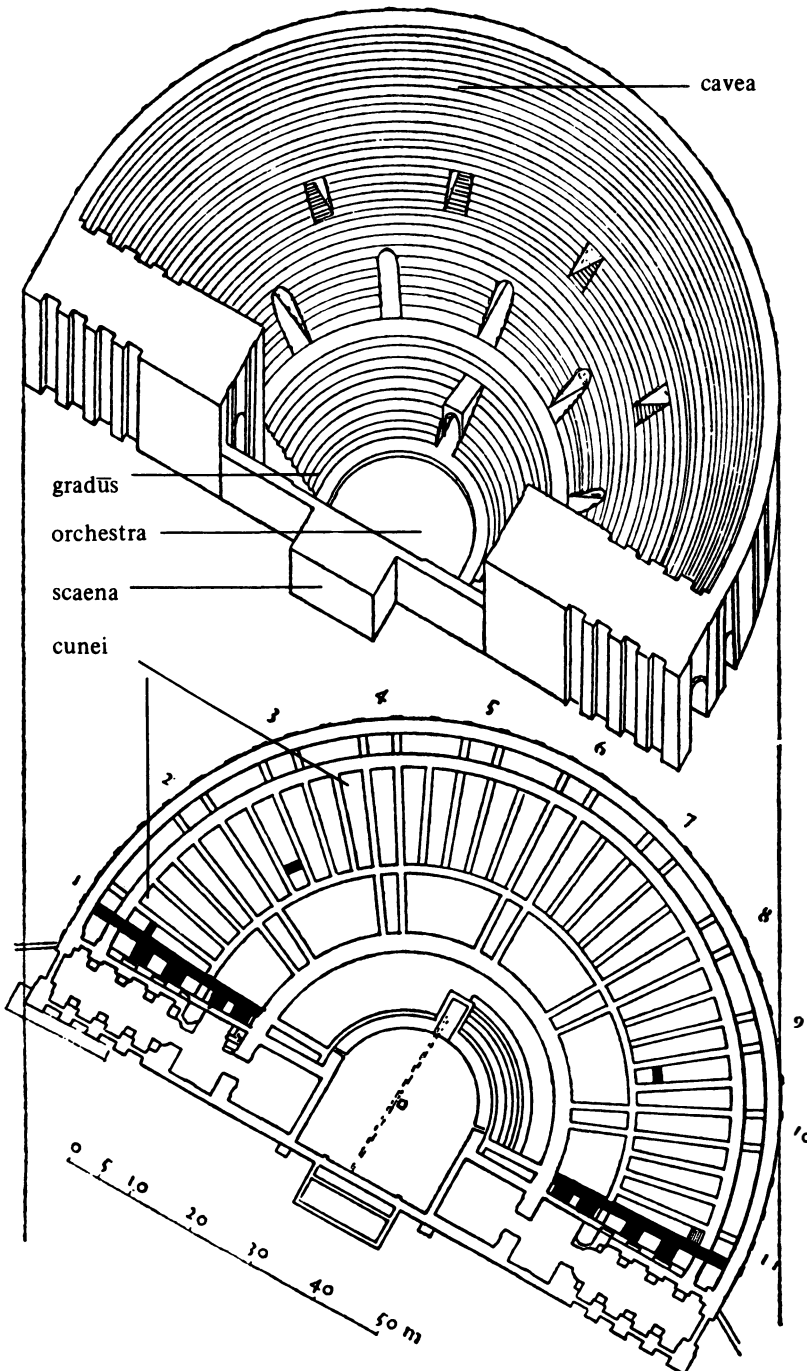

imago theatrum
Aventici inven-
tum monstrat

thermopolium –i, n.

est *caupona*, ubi calida venduntur.

Plautus, *Trinummus*, 1013/14:

„satin in thermopolio
condalium es oblitus, postquam
thermopotasti gutturem?“

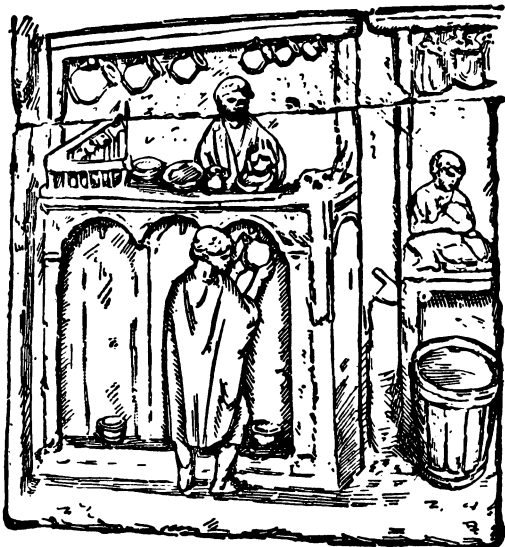

thyrsus –i, m.

est hasta aculeata, hederis et pampinis oblecta, quam Bacchus gestare solitus fuit et Bacchae in orgiis quatiebant.



tiara –ae, f. (vel tiaras, –ae, f.)

tiara est ornamentum capitis. erat in usu apud Persas, quorum reges soli recta tiara et cum apice utebantur. etiam apud Phrygas fuit eius usus, sed sacerdotibus praecipue et regibus.



tiara recta



tibicen –inis, m. (tibicina, –ae, f.)

tibicen est is, qui tibiā canit.

Cicero, de orat. 2, 83, 338:

„tibicen sine tibiis canere (non potest).“

tibia, –ae, f.

a) tibia est os cruris exterius.

b) tibia dicitur instrumentum musicum, teres et foraminosum, ex arundine aut buxo aliove ligno, vel ex cruribus gruum, cervorum aut asinorum, interdum ex ebore, aere aliave materia ductili. (*instrumenta musica*)



tibicen



tibicina

tignarius –i, m.

faber tignarius tigna dolat, in asseres et tabulas secat et domorum tecta et contignationes facit. (*contignatio*)

serra scalprum runcina

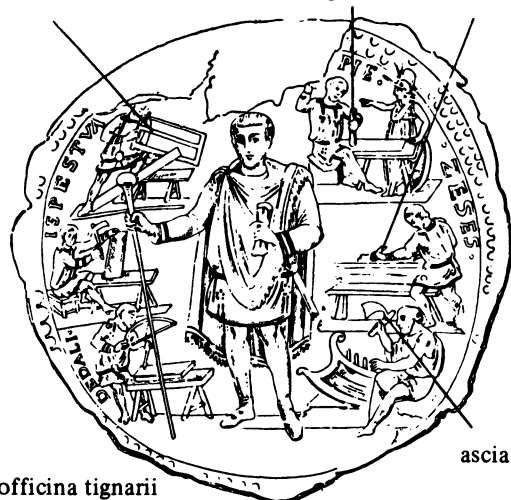

officina tignarii

discus vitreus ornamentis inauratis praeditus

tinctor –oris, m.

nomen actoris, derivatum a verbo tingere (tinxi, tinctum).

tinctorium dicitur de loco, ubi vestes tinguntur. actio tinctoris est tinctura, i. e. infectio, inductio coloris.



imago repraesentat *titulum* sepulcralem cuiusdam tinctoris, varia utensilia ostendentem, ut spatham (1), ampullas colorum (2), libram (3), lanæ glomera (4)

tintinnabulum –i, n.

est instrumentum e metallo (ex aere, stanno, argento aut plumbo) factum, quod percussum tinnitum edit.

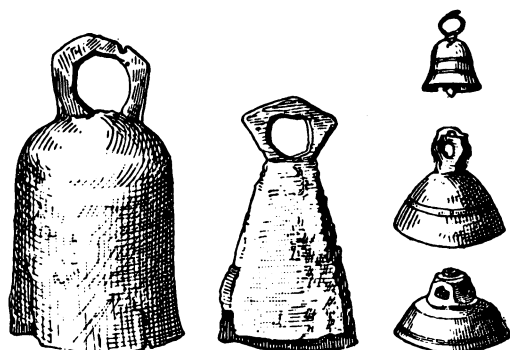

titulus –i, m.

est inscriptio, *nota*, *index*, elogium, quo res dignoscitur, et quid valeat, contineat, cuius sit, cur facta sit, monstratur, ut titulus sepulcri, aedium, libri, statuæ, picturæ et huiusmodi; exempli gratia titulus, qui in ecclesiâ Wettingen, prope Aquas, parieti (*paries*) infixus est: DEAE ISIDI TEMPLUM A SOLO L. ANNUSIUS MAGIANUS DE SUO POSUIT VIK (anis) AQUENSIB (us) AD CUIUS TEMPLI ORNAMENTA ALPINIA ALPULNA CONIUNX ET PEREGRINA FIL (ia) (denarios) C DEDE- RUNT L (ocus) D (atus) D (ecreto) VICANORUM.

torculum –i, n.

vel torcular, –aris, n.

est locus, ubi prelum est et prelum ipsum. (*pressorium*)

vinea, –ae, f. est locus, vitibus consitus vel multitudo vitium simul consitarum = vinetum. interdum vinea dicitur pro una vite,

Phaedrus, 4, 3:

„vulpes alta in vinea uvam appetebat summis saliens viribus.“

uva est fructus vitis.

Varro, r. r. 1, 54, 1:

„in vinetis uva cum erit matura, vindemiam ita fieri oportet, ut videas, a quo genere uvarum... incipias legere.“

Tibullus, 2, 1, 45:

„aurea tunc pressos pedibus dedit uva liquores.“

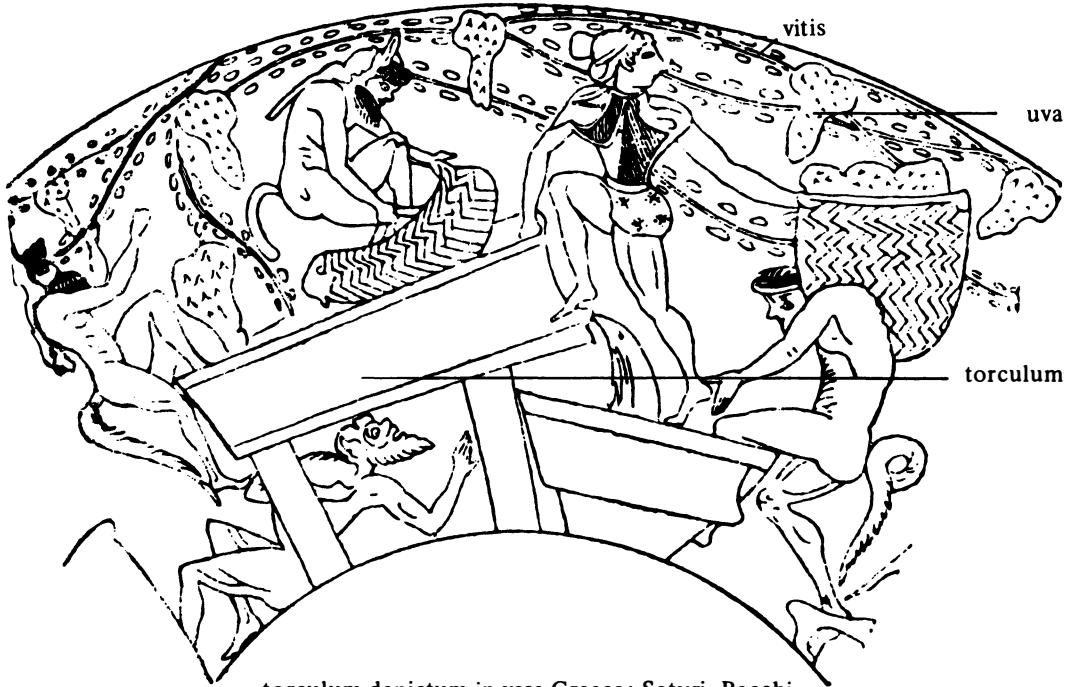

torculum depictum in vase Graeco: Satyri, Bacchi servitores, uvas pedibus in torculo premunt.

torus —i, m.

a) torus est funiculus tortus, qui duplicatus aut triplicatus funem facit.

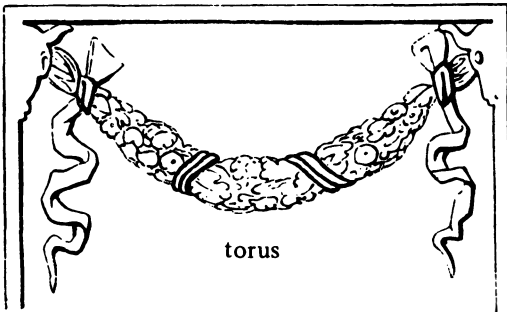

b) in architectura, torus est membrum turgens, rotundum et oblongum instar funis.

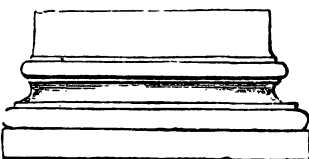

tori in basi columnae

c) item dicitur de venis tumentibus.

d) translate torus est culcita, quae lecto (*lectus*) imponitur sive discubitorio sive funebri sive cenatorio, sic dicta a rotunditate pulvinorum, quibus discumbentes incumbant.

Vergilius, Aen. 2, 2:

„inde toro pater Aeneas sic orsus ab alto.“

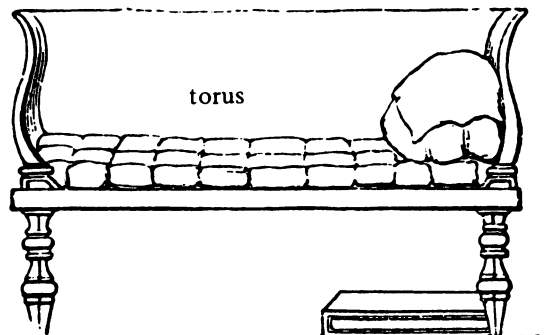

traha —ae, f. vel trahea, —ae, f.

traha est genus vehiculi sine rotis (*rota*), quo rustici utebantur et quo per nivem vehuntur.

etiam est machina, qua *navis* e mari in siccum trahitur.

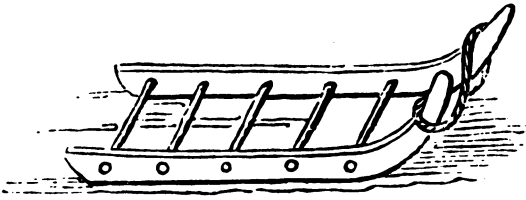

transenna –ae, f.

transenna significat opus cancellatum seu reticulatum.

- a) est *rete* ex funiculis cancellatis factum ad struendas avibus insidias.
- b) etiam *crates* seu cancelli ferrei vel lignei vel viminei, qui fenestris aut etiam mercibus oppositi visui pervii sunt.

formula dicendi: „per transennam aspicere aliquid“ = non propius neque singillatim, sed procul, obiter et summatim inspicere.

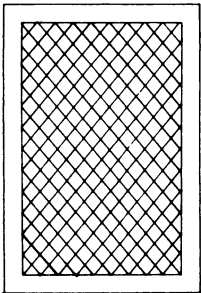

triclinium –i, n.

tres lecti (*lectus*) tricliniaries modo soleae (*solea*) ferreae circum mensam positi, in quibus novem convivales accumbebant. sinistro cubito nixi dextra manu cibos sumebant de mensa. (*corpus humanum, domus Romana*)



tridens –entis, m.

est instrumentum tribus dentibus vel cuspidibus munitum (est „*tricuspis*“, „*trifidus*“). dicitur etiam de ferro piscatorio, hastae praefixo, quo maiores pisces transfiguntur (= *fuscina*). tridens *symbolum*, attributum est dei Neptuni. tridens fuit telum gladiatoris *retiarii*.



**triforium –i, n.

adi. triforis, h. e. tres fores ostentans. triforium est *porticus*, quae totum aedis sacrae aedificium ambit, eo fine ducta, ut transitum praebet locum circumire vel lustrare volentibus, in ipso aedis muro, supra inferiorum columnarum (*columna*) et arcuum (*arcus*) ordinem.

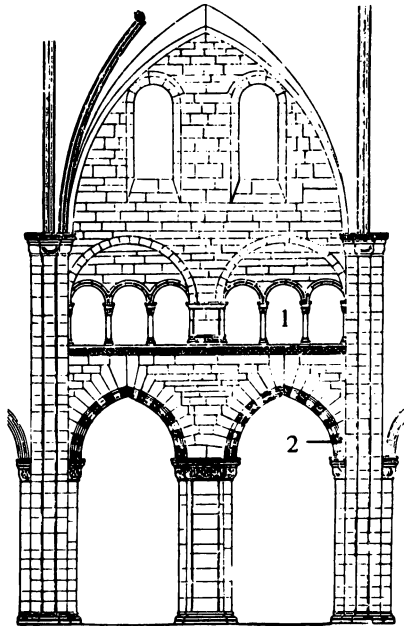

1 triforium in interiore ecclesia cathedrali Basiliensi
2 ordo inferiorum arcuum

Triptolemus –i, m.

Atheniensis, filius Celei, regis Eleusinis. is primus in Graecia agriculturae rationem creditur invenisse. de eo haec fabulantur: cum eius pater Cererem, filiam quaerentem, liberalissime hospitio suscepisset, illa pro remuneratione ostendit ei omne genus agriculturae,

filium etiam eius Triptolemem recens natum, per noctem igne fovit, divino lacte nutrit et eum alatis serpentibus superpositum, per totum orbem misit ad usum frumentorum hominibus indicandum.

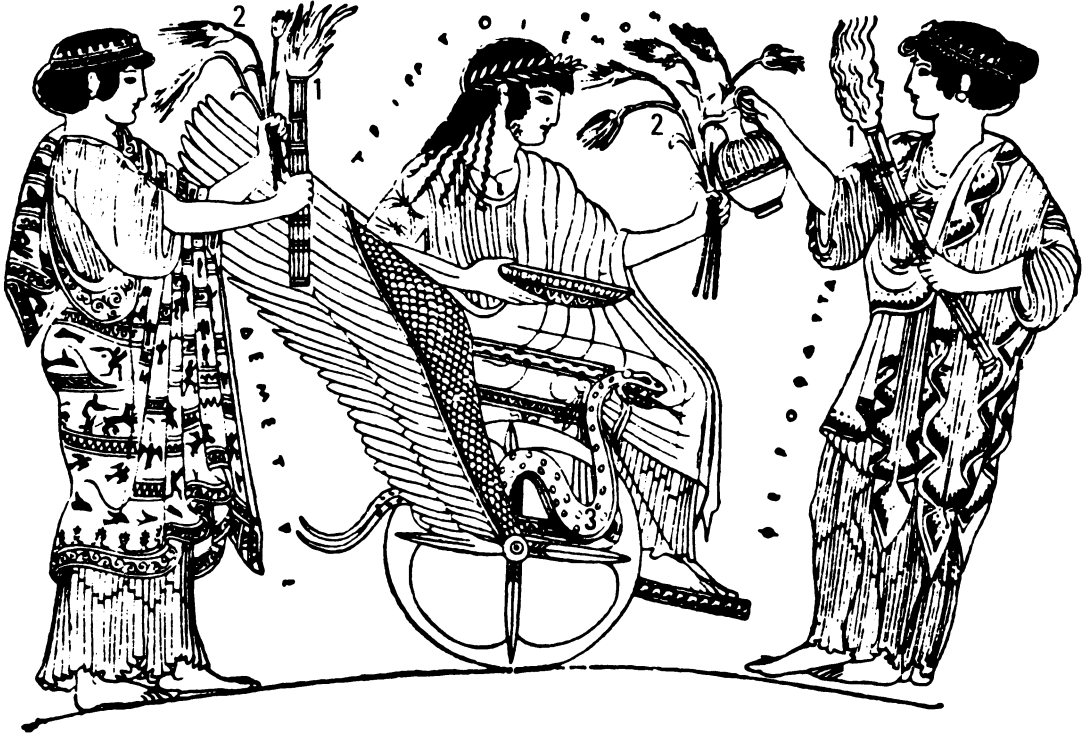

in imagine sinistrā est Ceres, dextrā Proserpina. ambae deae facem (1) mysteriorum tenent, Ceres Triptolemusque manipulum (2) spicarum portant. (*fax, manipulus, spica*) (3) serpens alatus.

tripus –odis, m.

tripus est, qui tres pedes habet vel fulcra, quibus sustinetur, ut vas, sella et huiusmodi. (*cortina*)

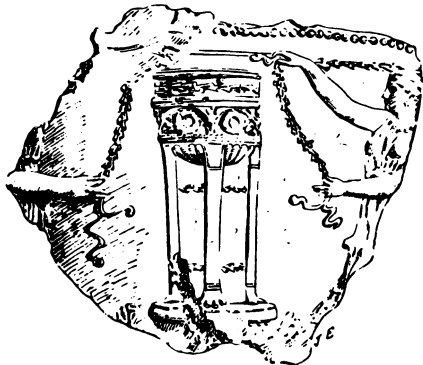

Pythia in tripode sedens, de qua Lucretius 1, 739: „Pythia quae tripode a Phoebi lauroque profatur.“



Triton –onis, m.

Triton est semideus marinus, filius Neptuni et Salaciae nymphae marinae, quem poetae fingunt Neptuni tubicinem esse eius-que tubam (tuba) etiam latissime longissimeque sonantem. Triton hominis atque piscis formam habet volatque supra mare curru equis caeruleis recto; saepe etiam sub forma centauri natantis apparet. conchā marinā canere solet. in dorso

Tritonum saepe Nereides, semideae marinae, filiae Nerei, dei maris, per mare vehuntur, animas heroum mortuorum ad campos Elysios in ultimo Oceano sitos, comitantur, itaque saepe in sarcophagis (sarcophagus) Romanis imago clipeata (clipeus) mortui inter Tritones Nereidesque sita invenitur.

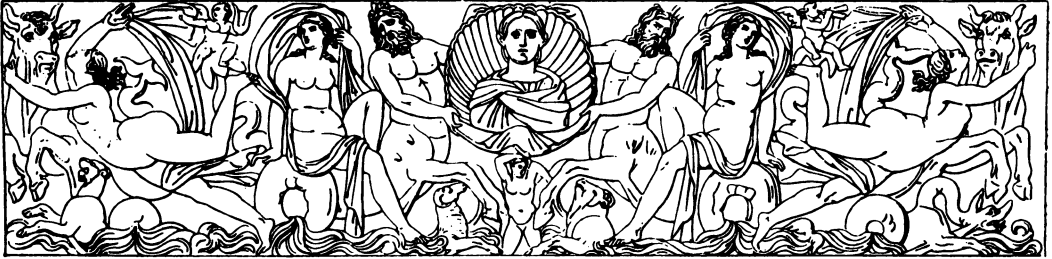

Tritones Nereidesque

trivium –i, n.

trivium est locus in quem tres viae conveniunt, ut bivium, in quem duae, quadrivium in quem quattuor. (compitum)

trivia et quadrivia erant rusticorum sacris attributa, nam ibi oves caedebant et sarta appendebant.

**trivium nominantur tres primae artes artium liberalium, nempe grammatica, rhetorica, dialectica. (artes liberales).

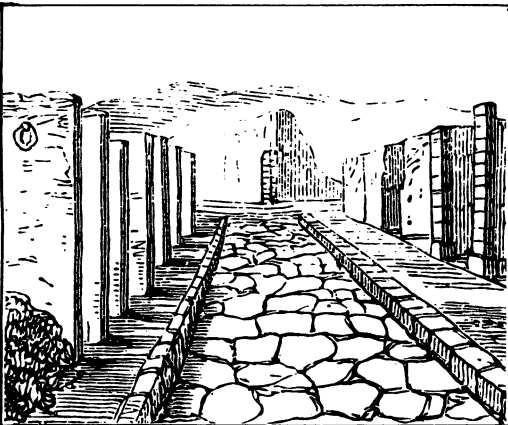

trochus –i, m.

est circulus seu rota ferrea, quae ludi causā a pueris ferreo manubrio, quod clavis dicebatur, impulsa mittebatur. habebat saepe circum infixos parvos anulos, qui dum iaceretur, tintillum et sonum reddebant. trochus differt a turbine, quia turbo erat ligneus, sed non circularis, at in modum metae factus.

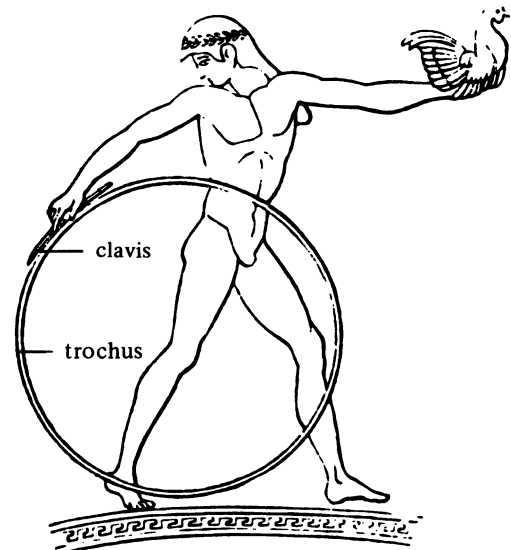

Ganymedes trochum clave impellens

troia vel trua

vel Troianus ludus, erat equestris ludus puerorum apud Romanos, qui cursu labyrinthico constabat. ludus Troianus a Vergilio in Aeneide 5, 583 ss. describitur, ubi equites „alternos ... orbibus orbis impediunt.“
(*labyrinthus*)



in vase Etrusco (Tragliatella) duo equites e labyrintho, qui „trua“ appellatur, egrediuntur

trua –ae, f. demin. trulla

trua est vasis genus planum, foraminibus instructum ad spumam adimendam vel miscendum extrahendumve aliquod ex aquis.



turbo –inis, m.



puella Attica turbinem agitans scuticā. imago vasis Graeci

turbo dicitur quidquid in *gyrum* vertitur, circumagitur.

a) speciatim est ventus vorticosus et validissimus, qui obvia quaeque prosternit, et ipse *vertex*, quem ventus efficit.

Seneca, quaest. nat. 5, 13, 3:

„ventus circumactus et eundem circumambiens locum et se ipsa vertigine concitans, turbo est.“

b) genus instrumenti lusorii, nempe lignum formā metae inversae, ima sui parte in acutum desinens, in summo latius, quod a pueris scuticā vel *clave* circumagitur.

turris –is, abl. turri, acc. turrim, f.

turris est aedificium in magnam altitudinem protensum, alta moles.

turris aequa cum muro est urbis *propugnaculum*.

turris vocatur etiam machina bellica, aedificium ligneum, in magnam altitudinem erectum subiectisque rotis huc illuc mobile.

adi. turrītus: turribus instructus.

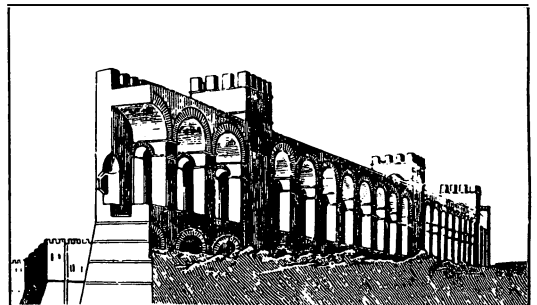
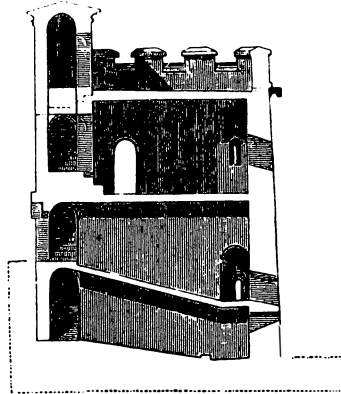

turres in moenibus Pompeianis

tympānum –i, n.

est triangulum sub fastigio (*fastigium*) templi, statuis vel opere caelato exornatum.



tympānum templi Athenae antiqui



tympānum supra porticum ecclesiae cuiusdam Medii Aevi, maiestatem Domini cum quattuor symbolis evangelistarum perhibens. (maiestas domini, symbolum)

typus –i, m.

(Gr.) *nota, signum*, forma percutiendo seu pulsando impressa, ut vestigium humi pede impressum.

typus etiam idem est quod ectypum: opus caelatum.

**typus apud scriptores ecclesiasticos: typi dicuntur figurae rerum seu personarum, quae in Novo Testamento futurae erant.

Ambrosius, 3 de David 11, n. 89:

„ille (Melchisedech) in typo, hic (Christus) in veritate: typus autem est umbra veritatis.“

***a temporibus Gutenbergi typis aeneis libri, acta diurna aliaque imprimuntur: ars typographica vel typographia.

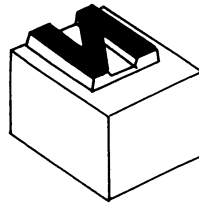

typus aeneus

***typographia –ae, f.

ars impressoria a Iohanne Gutenberg circiter anno 1440 Maguntiae inventa est. typos aeneos

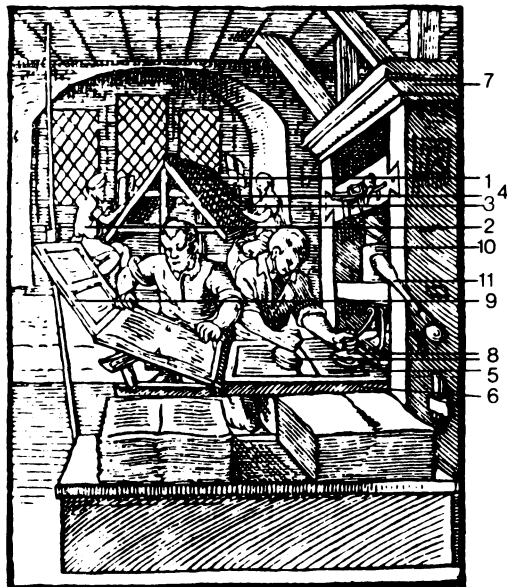

mobiles excogitavit, quos typotheta in verba composuit. post impressionem iidem typi aenei iterum in alia verba componebantur. His fere verbis Iohannes Amos Comenius in suo libro „Orbis Sensualium Pictus“ denominato opus typographicum describit (xylographia XVI. saeculi officinam typographi illustrans):

„typographus habet aeneos typos magno numero distributos per loculamenta (1), typotheta (2) eximit illos singulatim et componit [secundum exemplar, quod retinaculo (3) sibi praefixum habet] verba gnomone (4) donec fiat versus; hos indit formae (5) donec fiat pagina eosque coartat marginibus ferreis (6) ne dilabantur; ac subicit prelo (7). tum impressor ope pilarum (8) illinit atramento impressorio, superimponit inditas operculo (9) chartas, subditas trochleae (10) sucula (11) impressas facit typos imbiberē.“

1) loculamenta 2) typotheta 3) retinaculum
4) gnomon 5) forma 6) margen ferreus
7) prelum 8) pilae 9) operculum 10) trochlea
11) sucula

umbilicus –i, m.

a) est regio media alvi et abdominis, cavitate quadam praedita, vestigia servans vasorum, per quae fetus, dum est in utero matris, nutritur.

b) a similitudine umbilicus dicitur media pars cuiusque rei, ex. gr. locus terrae:

Cicero, Verr. 4, 48, 106:

„qui locus, quod in media est insula situs, umbilicus Siciliae nominatur.“

etiam Delphi umbilicus terrae dicuntur.



umbilicus Delphorum

umbo –onis, m.

a) umbo est quidquid in plano rotundā aut coni figurā exstat ac prominet; speciatim dicitur sic media pars clipei eminentior.

b) umbo et ipse clipeus nominatur.

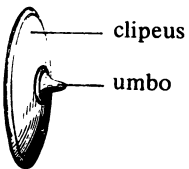

c) latiore sensu a similitudine, umbo dicitur quidquid prominet et protenditur ac aliquid protegit, ut lapides in margine crepidinis. (crepido)

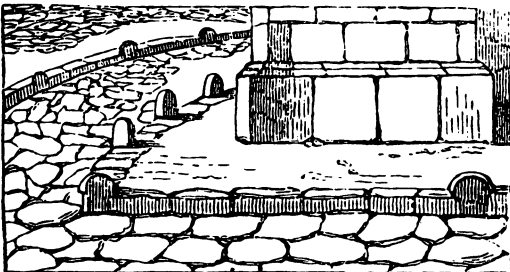

umbones in margine viae

umbraculum –i, n.

a) est locus, in quo est umbra, locus compositus et tectus frondibus aut alia re quacumque ad umbram praebendam, tabernaculum velumve umbrae causā erectum.

b) sumitur quoque pro umbrella, qua tegitur facies ad solis calores arcendos.



unguentum –i, n.

est omnis sucus pinguis, quo unguimur deliciarum et luxūs causā.

Plautus, Mostellaria 41:

„non omnes possunt olēre unguenta exotica.“

unguentarius, –i, m.

est homo, qui unguenta conficit et vendit.

Seneca, quaest. nat. 4b 13, 8:

„unguentarios Lacedaemonii urbe expulerunt et prope cedere finibus suis iusserunt, quia oleum disperderent.“

unguentarium (sc. vas)

e vitro aut alabastro factum

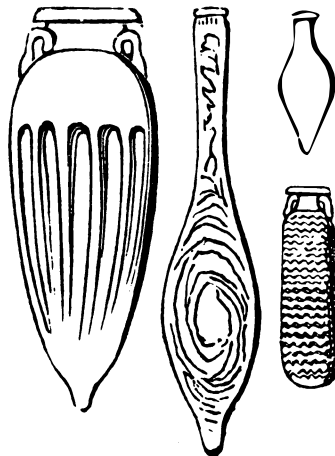

vasa unguentaria

urceus –i, m.

est vas ansatum, plerumque fictile ad varios usus et praecipue ad ministrandam aquam. (*ansa*).

adverbium: urceatim:
Petronius, sat. 44, 18:

„Iovem aquam exorabant, itaque statim urceatim pluebat.“

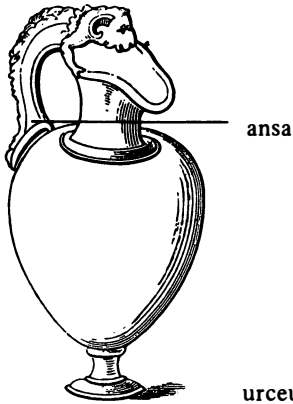

urna –ae, f.

est vas, quo aqua e puteis (*puteus*) fluminibusque hauritur. ansulis instructum erat, ut pro more umeris vel capite gestaretur.

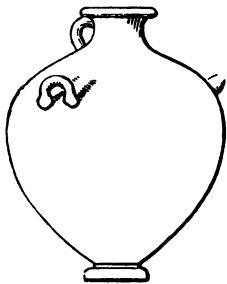

utensilia –ium, n. pl.

dicuntur quaecumque usui nostro sunt necessaria.

Columella, r. r. 12, praef. 3:

„utensilia, quibus aut alitur hominum genus aut etiam excolitur.“

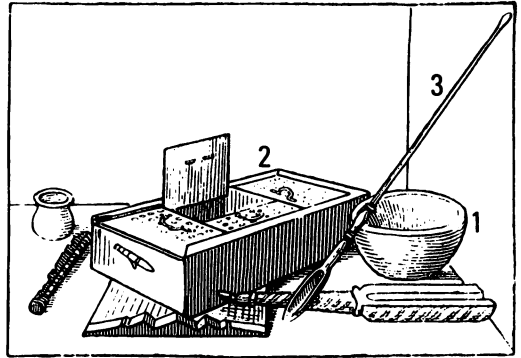

in imagine depicta sunt utensilia pictoris: mortarium (1), in quo colores teruntur, scrinium colorum (2), penicilli (3)

uter –tris, m.

est pellis, qua vinum aut oleum aut alia quae-piam similis res deferri solet.

Petronius, sat. 34, 4:

„intraerunt duo Aethiopes capillati cum pusillis utribus, quales solent esse qui harenam in amphitheatro (*amphitheatrum*) spargunt, vinumque dedere in manus ...“

utre uncto in lusu utebantur:

Vergilius, Georg. 2, 384:

„mollibus in pratis unctos saliere per utres.“ (vide imaginem!)

frequens fuit apud veteres utrium usus ad flumina trananda.

utrarii sunt qui exercitum sequentes aquam utribus ministrant.

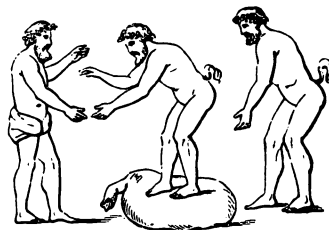

satyri utre uncto ludentes

****utopia** –ae. f:

est urbs „nullius loci“, quae nullum locum habet (Graece: u topon echei = non habet locum) i. e. quae nusquam terrarum est. hoc nomine Thomas Morus, scriptor Anglicus - Latinus, rem publicam optimis moribus atque institutis instructam appellavit, qua optimum civitatis statum nusquam perfectum monstraret.

**exinde omnia, quae solum ideis, nondum operā perfecta sunt, „utopiae“ nominantur.

Libellus vere aureus nec

**MINVS SALVTARIS QVAM FESTI-
vus de optimo reip. statu, deq; noua Insula Vtopia
authore clarissimo viro Thoma Moro in clytæ
ciuitatis Londinensis ciuic & viccomite cu-
ra M. Petri Aegidii Antuerpiensis, & arte
Theodorici Martini Aluftenſis, Ty-
pographi almae Louanicnsium
Academix nunc primum
accuratissime cdi-
tus.:**

utricularius –i, m.

a) utricularius est qui utriculos seu utres inflatos ratibus ita subiiciebat, ut iisdem flumina transnare possent. horum opificum collegium in quibusdam urbibus ad flumen aliquod situs habebatur. ideoque saepe utricularii cum nautis coniunguntur. (*uter*)

b) utricularius est etiam qui canit tibiis paruo utri infixis, eum subinde inflando (= ascaules). (*instrumenta musica*).



utricularius

vadum —i, n.

est locus in mari aut flumine, ubi aqua brevis est et pedibus transiri potest.

Caesar, B. G. 1, 6, 2:

„Rhodanus ... nonnullis locis vado transitur.“

translate: in vado esse = in tuto esse.

res est in vado salutis = res iam salva est.

vates —is, m.

est sacerdos (m. et f.) dei voluntatem hominibus nuntians.

saepe etiam poeta a deo instinctus vates vocatur.

verbum: vaticinor, —ari.

subst. verbale: vaticinatio.

proverb.: „vaticinium ex eventu“, est vaticinatio falsa, quae post eventum profertur.

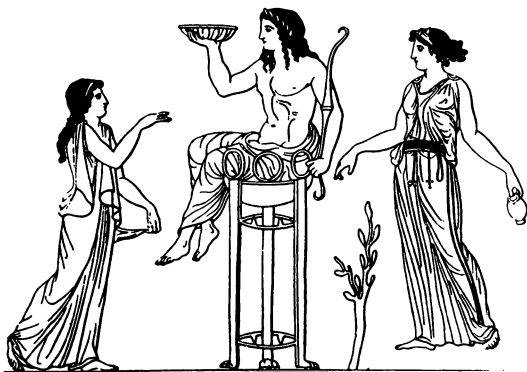

tripus laurus

imago e vase Graeco, hodie deperdito (e coll. Hamilton) deum Apollinem in tripode (*tripus*) vaticinantem monstrat, manu sinistrā arcum, manu dextrā patellam tenentem

vellus aureum

vellus, —eris, n.

a) lana ex ove dempta et conglobata.

b) de ipsis lanatis ovium pellibus; vellus aureum est vellus eius arietis, qui Phrixum (*Phrixus*) et Hellen supra mare portavit.

Argonautae (*Argo*) duce Iasone vellus aureum a dracone custoditum in Colchide quaerebant.

c) ****ordo velleris aurei** erat ordo equitum a ducibus Burgundionum instauratus.

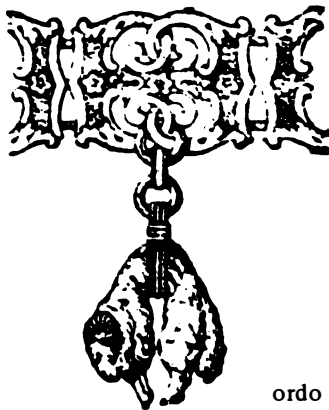

ordo Velleris Aurei

velum —i, n.

a) est linteum in mālo *navis*, quod expansum ventos excipit et navem impellit.

b) est linteum, pannus, aulaeum ad quidpiam tegendum, exempli gratia velum theatri umbram spectatoribus praebens.

velum in amphitheatro Pompeiano



venatio —onis, f.

est ferarum persecutio; a verbo „venari l“.

venator est qui bestias feras sagitta, pilo, *funda* aut etiam *fovea* aut retibus (*rete*) persequitur. dea venatrix apud Romanos erat Diana.



Hercules fundā aves Stymphalias venatur in vase Graeco picto

ventus -i, m.

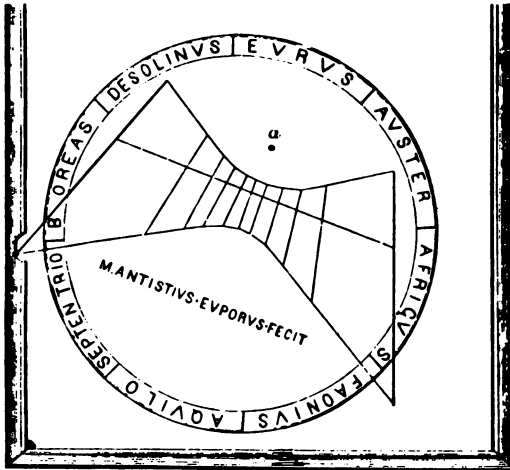

est aeris concitati motus, fluctus aeris impetuosior.
 imago nostra *horologium* solare Aquileiae inventum monstrat, ubi octo venti distinguuntur: Eurus, Auster, Africus, Favonius, Aquilo, Septentrio, Boreas, Desolinus.
 formulae: „ventis dare vela“.
ventus secundus et ferens est ventus, qui cum cursu nostro flat, ventus adversus, qui contra nos flat. hinc: res secundae, res adversae.

ventus secundus

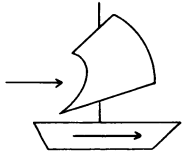

ventus adversus

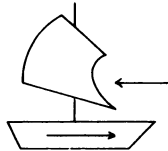

vertex -icis, m. (vel vortex, -icis m.)

vertex est universim id, quod vertitur, itemque id, circa quod aliquid vertitur.

Quintilianus, 8, 2, 7:

„ut vertex est contorta in se aqua (*gurges*) vel quidquid aliud similiter vertitur: inde propter flexum capillorum, pars est summa capitis: et ex hoc, id, quod in montibus eminentissimum.“

vertex:

- a) contorta in se aqua.
- b) flexus capillorum in summo capite = summum caput.
- c) summus mons.

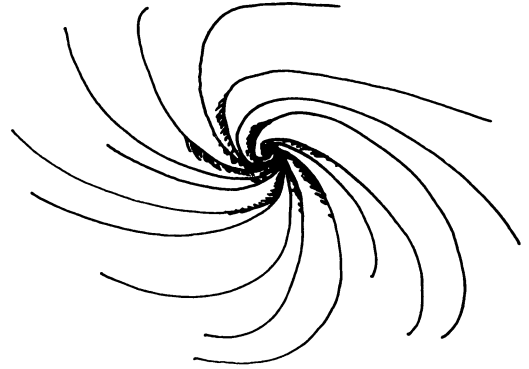

veru -us, n.

veru est instrumentum ferreum aut ligneum oblongum cuspidatum, cui infinguntur carnes igni torrendae. (*crates*)



cuspis

Vesta, Lares, Penates

Lares (lar, -aris, m.) erant vicorum atque itinerum dei et tectorum domuumque custodes. (Arnobius, 3, 41).

et Penates dei tutelares domus sunt.

Lares tamquam feles semper eodem loco manent,

Penates cum hominibus coniuncti sunt ut canes, qui dominum sequuntur.

Vesta dea focum domus repraesentat.

Penates homines comitantur cum e terra sua emigrant.



in imagine Pompeiis reperta videmus deam Vestam in solio sedentem. dextra manu pateram tenet, sinistra cornu plenitudinis (cornu copiae). post eam est asinus, bestia Vestae attributa. Iuvenes caput frondibus coronati Lares sunt. e cornibus aquam aut vinum in vas fundunt. in aliis imaginibus saepe circum Vestam saltant.

Vestalis -is, f.

Vesta est dea foci; forma eius templi est circularis. erat ibi ignis, qui perpetuo servabatur a virginibus Vestalibus. Vestales virgines institutae sunt a rege Numa, quattuor numero; postea numerus earum auctus est. votum virginitatis strictissime eis servandum erat. privilegiis atque honoribus donabantur. cum enim exhibant, licitor praecedebat cum securi fascibusque (miles Romanus).

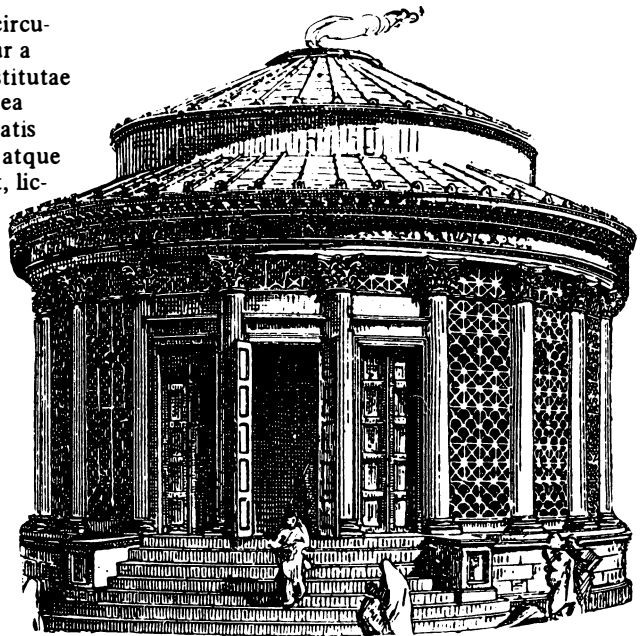

templum rotundum Vestae (reconstr.)
quod dicitur

vestiarius –i, m.

est mercator pannorum vestiumque ut opus caelatum monstrat, quod officinam aut tabernam vestiarii repraesentat.

vestiarium, –i, n.
est locus, ubi vestes aliaeque res reponuntur.
(*officina, taberna*)



vestibulum –i, n.

est locus ante aedium ianuam, inter aedes ipsas et viam relictus, eum in usum, ut qui aedium dominum salutatum venissent, neque in via

starent neque in ipsius essent aedibus.
(*domus Romana*)

vestimenta Romana

vestimenta virorum

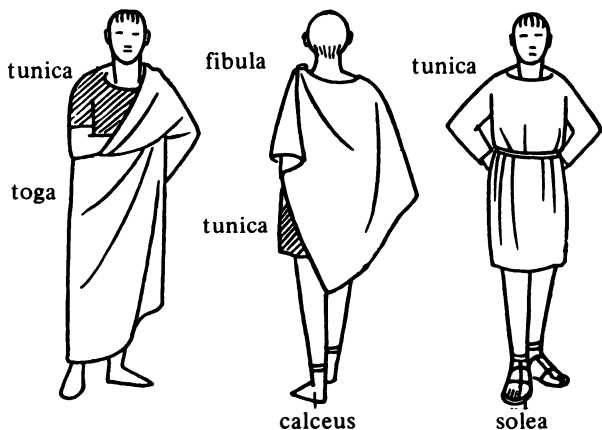

vestimenta mulierum

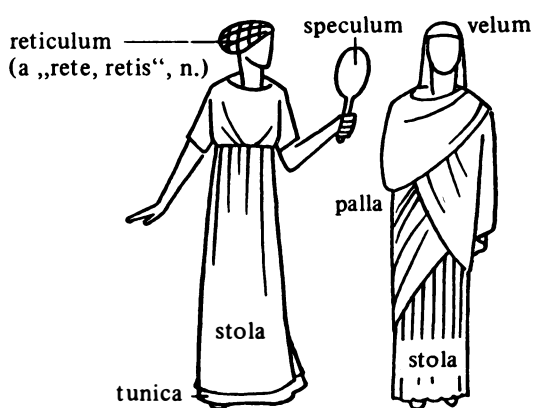



viator cum *cuculla*
e fonte (*fons*)
aquam hauriens.

vigiles, vigiliae

vigil (-is) est is, qui vigilat, qui non dormit.
vigiles sunt excubitores nocturnique custodes.
vigilia, -ae, f. est vigilatio, insomnia. in re
militari vigilia dicitur, quae fit a militibus custo-
diendi causa.

vigiliae militares quattuor erant, prima, secunda,
tertia, quarta. singulae tribus horis constabant.
noctes in duodecim horas dividebantur, quae
aestivo tempore breviores, hiemali tempore
autem longiores erant.

Hieronymus, ep. 140, n. 8, 2:

„nox in quattuor vigiliis dividitur, quae singulae
trium horarum spatio supputantur ...“



imago vigiliae militaris ex Aeneide Vaticanā
sumpta.

villa rustica

et res, quae simul cum vocabulis Latinis a
Germanis receptae sunt:

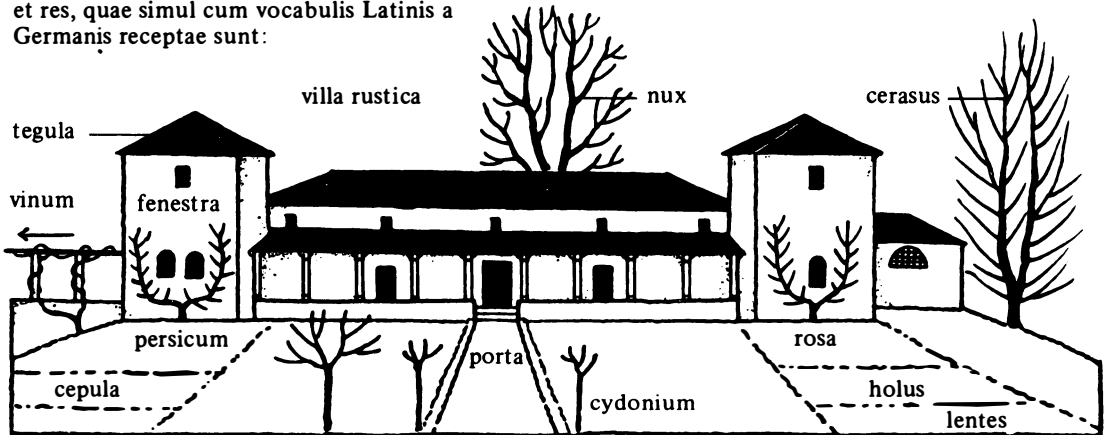

in campo:

arbor

cerasus, f.
cydonia, f.
buxus, f.
prunus, f.
nux, f.

fructus

cerasum
cydonium
prunum
nux, -cis, f.

in horto:

vinum, vindemia,
rosa, persicum,
lens, lentis, f.
holus, -eris, n.
cepa, cepula

in re aedificatoria:

calx, -cis, f.
tegula, -ae, f.
spicarium, -i, n.
cellarium, -i, n.
vallum, -i, n.

mortarium, -i, n.
fenestra, -ae, f.
coquina, -ae, f.
solarium, -i, n.
pilare, -ris, n.

murus, -i, m.
porta, -ae, f.
caminus, -i, m.
camera, -ae, f.

Aliquot res sine nominibus Latinis in Germaniam introductae sunt a Romanis, ut lycopersicum, faba, pisum.

vitta –ae, f.

a) vitta est ligamentum, fascia, cingulum, quo antiqui aliquid religabant.

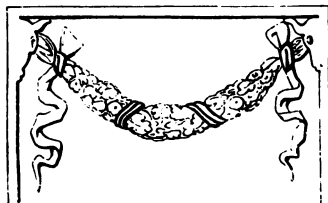

b) vitta est fascia, qua *arae* ornabantur et *hostiae*.
c) vitta est ligamentum capitis, quo antiqui crines cingebant colligebantque, et quod etiam adhibebatur in sacris.



Vulcanus –i, m.

a) fuit filius Iovis et Iunonis, qui a parentibus ob deformitatem caelo praecipitatus est deiectusque in Lemnum insulam. eā ruinā, quā decidit de caelo, claudus factus est. deus ignis et fabrorum praeses putatus est et fingitur etiam faber deorum, qui Iovi fulmina et ceteris deis arma adversus Gigantes fabricavit. officinam autem habere fertur in Lemno una cum Cyclopibus ministris. Venerem uxorem duxit, quam cum postea una cum Marte deprehendisset in adulterio, ambos reti et invisibilibus catenis ita colligavit, ut neuter abire posset, donec ab omnibus deis deabusque visi et derisi sunt.

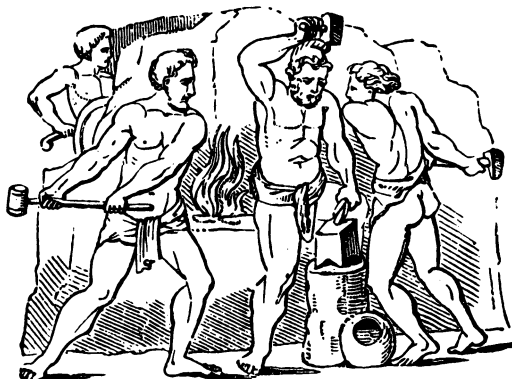

opus caelatum: Vulcanus ad incudem (*incus*) stans cum tribus Cyclopiis malleis (*malleus*) ferrum tundit

Vulcaniae insulae, etiam Aeoliae nominantur. septem insulae sunt in mari Tyrrheno citra Siciliam sitae, quarum una est Lipara: omnium autem terra sulphurea est et ignem per intervalla evomens: inde fabulantur, ibi esse Vulcani officinam.

b) Vulcanus etiam metonymice de igne dicitur. Plautus, Amph. 341:

„quo ambulas tu, qui Vulcanum in cornu conclusum geris?“

h. e. ignem geris in *laterna* cornea.

c) **Vulcani etiam montes ignivomi nominantur, ut Aetna, Vesuvius.

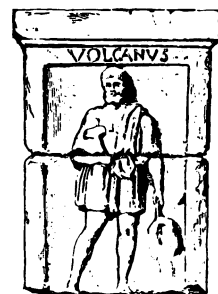

vomitorium –i, n.

in theatris (*theatrum*) et amphitheatris (*amphitheatrum*) erat ostium seu aditus, per quem populus ab internis porticibus (*porticus*) et scalis (*scala*) exibat in gradus et sedilia.

Macrobius, Sat. 6, 4, 4:

vomitoria „... unde homines glomeratim ingredientes in sedilia se fundunt.“

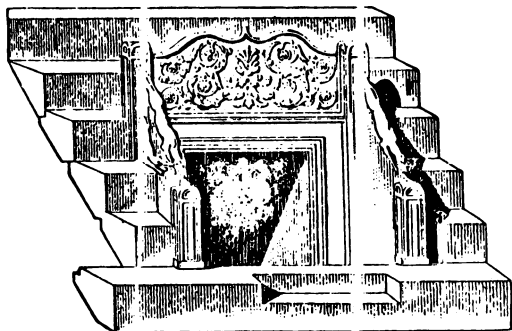

****xylographia**

e prima Utopiae editione sumpta, quae insulam Utopiam a Thoma Moro inventam monstrat (*utopia*).



imago titulum primae editionis (Lovanii 1516) praebet; Petrus Aegidius editor, Theodoricus Martinus impressor (typographus) fuit.

zodiacus –i, m.

haec imago est descriptio anni e codice conventus Sanctgallensis sumpta. monachus quidam Sanctgallensis saeculo nono post Christum natum annum duodecim signis zodiaci distin-

xit. usus est signis, quae iam antiquis temporibus inventa sunt. zodiacus est circulus eorum signorum stellarum, quae sol uno anno percurrit. (*balteus*)



zona –ae, f.

Gr. zōnē = cingulum.

a) zona est vinculum, quo cingimur: cinctus, *balteus*.

b) zonae dicuntur circuli quidam lati, caelum terramque veluti cingula quaedam ambientes. sunt autem numero quinque, ex quibus media, quae inter tropicos est, nimio calore, parum apta habitationi credita fuit; quae vero extremae sub Arctico et Antarcticis circulis sitae, nimio frigore horrent: unde et ipsae inhabitabiles habitatae sunt. reliquae autem, ut quae medium inter torridam et gelidam situm obtinent, temperatae sunt, humanae vitae accommodatissimae.

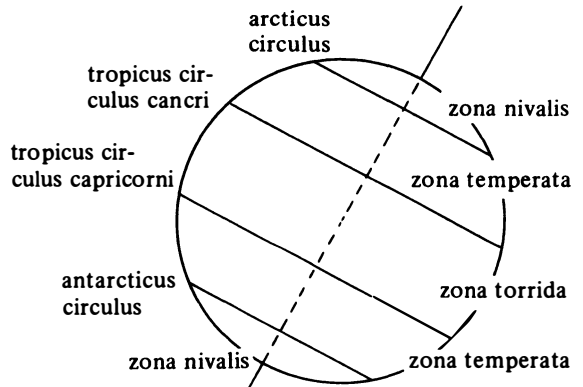

index vocabulorum

lemmata lineā subnotata sunt.

A

abacus 1, 2
abdomen 369
acanthus 2
Acheron 79
acia 4, 5
aconitum 3
acroterium 3
acta diurna 368
actor 268
aculeus 233, 324
acus 4
adolescens 9
adorans 5
ad perpendicularum 229
adverbia loci 209
aedes publicae 49
aedicula 5, 193
aedilis 384
aeditumus 7
aedituus 7
Aegaeus 248
aegis 7
aequinoctium 321
aequinoctium autumnale 322
aequinoctium vernum 321
aequipondium 204
aer 129
Aesculapius 8
aestas 173
aetates hominis 9
affinitas 9, 10
Africa 249
Africus 377
Agenor 131
agger 207
agitator 11
agitator aselli 11
agitator equorum 11
agricultura 361
ala 118, 126, 193
album 12, 252
albumen 252
alga 233
allocutio 12
Alsatia 245
altare 24

alticinctus 13, 80
alvearium 13
ambo 14
amita 91
amphiprostylos 343
amphitheatrum 14, 71
amphora 15
ampulla 15
ancora 16
Anglia 16
angulus 157
angulus acutus 158
angulus curvilineus 158
angulus mixtus 158
angulus obtusus 157
angulus rectilineus 158
angulus rectus 157
ansa 15, 17, 320
ansa crepidae 18
ansa gubernaculi 17
ansa ostii 17
ansa staterae 17
anser 214
antarcticus 312
antefixum 18, 341
antelucanus 298
ante lucem 298
antemeridianus 298
ante meridiem 298
antenna 31
antlia 18
antrorsum 294
antrum 19
anularius 103
anulus 336
anulus signatorius 315
anus 10
apalare 111
apex 139
Aphrodite 114
apiarium 14
aplustre 19, 31
apodyterium 45
Apollo 20
apotheca 246
apothoeosis 21
apsis 49, 109, 259

aqua 129
aquaeductus 22
aquarius 190
Aquarius 392
aquila 23
Aquila 377
Aquilegia 289
aquilifer 224
ara 23
aranea 260
aratio 297
arator 24, 278
aratrum 24
arca 25
architectura 28
architectus 25
arcticus 312
Arctus 312
arcus 27
arcus Iridis 215
arcus Titi 28
area 29
argilla cocta 348
Argo 29
Argonautae 18, 271
aries 334
Aries 322, 391
Arimaspi 164
arista 324
arithmetica 33, 34
arma militum 223
armamenta navis 31, 32
armarium 202, 321, 336
armilla 31
ars impressoria 367
ars mechanica 35
ars typographica 368
artes, septem artes liberales 33, 34
artifices et artificia 35, 36
arx 39
arx Sancti Angeli 219
as 39
ascaules 374
ascia 39, 355
Asia 249
asinus 88
aspersio 40
aspersorium 41
assultor 265
Asterias rubens 289
astragalus 41, 340
astronomia 33, 34
Atlantes 42
Atlas 42
atomus 42
atramentarium 186, 202
atramentum 186, 202, 303
atrium 125, 193
Atropos 261
audire 312
auditus 312

augur 43
augurium 43
augurium adversum 43
augurium prosperum 43
aulaeum 376
auricularis 103
aurifex 38
auriga 11
auris 104, 312
Aurora 44
Auster 44, 377
autumnus 173
aves Stymphaliae 377
avia 91, 92
avis 23
avis sacra 43
avunculus 92
avus 91, 92
axis 44, 229, 313

B
Baccha 353
Bacchus 353
baculus 207
baculum carbonis 274
balteus 46
balteus equi 46
balteus militaris 46
balteus theatri 47
balteus zodiaci 47
baptisterium 48
barbitum 184
Barcino 81
basilica 48, 109
Bellerophontes 51, 52
bidens 51, 52
bigae 53
bigatus 53
bilanx 192
bipalium 52
bisellium 54
bivium 363
Boreas 377
bovine 328
bracae 54, 224
bracchium 16, 104
Britannia 16
bruma 321
bucina 55
bucinator 55
bullae 56, 342
bulla aurea 56
bullatus 56
buris 24
buxus 385
Byzantium 57, 58

C
cadmia 274
caduceus 59
caducifer 59

cadus 59
caelator 37
calamus 186
calcar 60
calcator 60
calcatorium 60
calceus 105, 319, 336, 381
calco 61
caldarium 111, 176
calendarium 61
calidarium 45
caliga 61
calix 62, 348
Calliope 234
calvaria 250
calx 61, 104
calx (mat) 386
Camena 20, 234
camera 62, 72, 386
caminus 386
Campania 63, 64
Campanula 289
campi Elysii 364
campus 334
cancelli 63
Cancer 321, 391
candela 65, 195
candelabrum 65
canis venaticus 99
canthus 296, 333
capillus 103
capitulum 65
capitulum Corinthium 66
capitulum Doricum 65
capitulum Ionicum 65
Capricornus 321, 392
capsa 66
capsa acuum 5
capsula 66
caput 103, 238
cardines portae 67
cardo 66, 72, 313
cardo castrorum 67
Carnuntum 227
caro 290
carpentum 67
Caryae 68
Caryatides 68
casa 68
castellum 69
castellum aquarum 69, 70
Castor et Pollux 69, 70
castra 71, 72
castra stativa 72
catacumba 71, 5
Catadupa 73
catapulta 73
cataracta 73
catena 74
catenarius 74
cathedra 74

cathedralis ecclesia 75, 360
catinus 109
cauda 263
caudex, codex 91
caupo 75
caupona Pompeiana 76
cauponari 75
causa 143
cavea 76, 351
Celeus 361
cella 77
cella casearia 78
cella farinaria 78
cella lignaria 78
cella olearia 78
cella pomaria 78
cellarium 386
cella vinaria 78
cento 77
centuria 78
centurio 78
cepa 385
cepula 385
cerasum 385
cerasus 385, 386
cerebrum 250
Ceres 361
cereus 148
cernere 312
cervical 79
cervix 104, 250
cestus 80
Charon 79
charta 203, 261
chimaera 79
chorda 137
choroides 245
cicurare 216
cingulum 80, 224, 391
circinus 81, 155, 241
circulator 81
circulus 159, 391
circulus antarcticus 392
circulus arcticus 392
circumferentia 295
circus 81
circus Maximus 81
cirrus 83
cisterna 83
cithara 137, 183, 184
citharoedus 20, 234
civilis 156
classarius 84
classis 84
claustrum 85
clava 85
claviger 85, 86
clavis 86, 112, 364
clavus 86, 163, 290
clavus angustus 87
clavus annalis 87

clavus gubernaculi 87
clavus latus 87
clepsydra 174
Clio 233
clipeus 88, 223, 369
clitellae 88
clivus 334
cloaca 89
Cloaca Maxima 89
Clotho 261
cochlea 89
cochlear 90, 111
Cocytus 79
codex 203
codex rescriptus 255
codicillus 91
cognatio 91
cohors 91
cohors praetoria 92
collis 254, 334
collum 104, 249
colonia 93
colonia civilis 93
colonia militaris 93
colonus 93
colum 112
columbarium 93
columna 2, 219, 257, 274, 360
comoedia 268
commercium 94
communicatio 209
commutatio 93
compedes 95
compeditus 95
compendium 95
compitalia 95
compitum 95
compluvium 125, 126, 128, 193
concha marina 363
conclave 193
concordia 96
concupiscere 312
congiarium 96
congius 96
consecratio 97
consecratio Herculis 98
consobrina 92
consobrinus 92
consonantes 249
constratum 97, 290
constratum navis 97
constratum pontis 98
contignatio 98
conus 369
convenientia 220
convivium 199
copula 99
coquina 386
cor 104
corbis 99
corbita 100

cornicen 100, 225
cornu 31, 183, 225
cornu copiae 379
cornu plenitudinis 379
corona 101, 102
corona civica 101
corona muralis 102
corona navalis 102
corona obsidionalis 101
corona ovalis 101
corona triumphalis 101
corona vallaris 102
corpus 238
corpus humanum 103, 104
corrugia 105
cortex 252
cortina 105
costa 250
cranium 348
crates 106
crates ferrea 106
crepida 18, 336
crepido 106, 127
crepido viae 106
crepitaculum 107
crepusculum 298
creterra 112
cribrum 107
crista 108, 153, 224
crotala 185
crus 104, 157
crypta 108
crystallinus 246
Ctesibica machina 109
cubiculum 193
cubile 199
cubitum 104
cuculla 110
cucullatus 110
culcita 325, 358
culina 111
culmus 68
culter 111, 25
cultrarius 111
cumulus 112
cuna 179
cuneus 112, 351
cuniculus 113
Cupido 114
Cupidines 222
curator viarum 384
currus 114
currus alatus 115
currus triumphalis 115
currus volucris 115
cursor 265, 311
cuspis 378
cyathus 90, 111, 112, 316
cybernetica 164
Cyclops 388
cydonia 385

cydonium 385, 386
cymbala 183, 185

D

Daedalus et Icarus 117, 118

Danaides 117

Danaus 118

decumanus 118, 67, 71

defectio lunae 119, 120

defectio solis 119, 120

defensor 265

Delphi 119, 120

delphinus 44

denarius 53

dens 249

dentale 24

dentales 249

deorsum 294, 302

Desolinus 377

dextrorsum 5, 294

diadema 121

dialectica 33, 34, 363

diametrus 160

Diana 376

diatretum 122

dies 298

digiti manus 103

digiti pedes 104

digitis micare 222

digitus index 181

diluculum 298

Dioscuri 69

diptychum 121, 122

diptychum eburneum 122

discus 88

discus colorum 272

discus vitreus 355

diurnus 298

dividiculum 69

divortium 123

dolium 123

dolium Diogenis 123

dolium fictile 124

dolium pertusum 117

domitor ferarum 216

domus Romana 125, 126, 127, 128

E

ebur 122

eclipsis 119

ectypum 368

elementa 129

elementarius 129

ellyphnium 141, 210

ensis 224

eo 209

ephippium 129

episcopus 207

epitonium 130

epitonium electricum 130

epulones 199

equus funalis 149, 188

equus iugalis 149, 188

equile 328

Erato 234

etesiae 130

Eupalinus 114

Europa 131, 132, 249

Eurus 377

Euterpe 233

examen 131

exedra 132, 126

exemplar 272, 368

exemplar mythicum 97

exhedra 132

exsequium 316

extrosum 294

F

fabas 386

faber 388

faber aerarius 35

fabula palliata 256

fabula togata 256

facsimile 133

falx 52

farina 230

fascia 181

fasciculus 216

fascis 205, 225

fastigium 133, 3, 28

fauces 125

Favonius 377

favus 134

fax 134

femur 104

fenestra 108, 126, 385

ferculum 135

ferramentum 308

fetus 369

fibula 136, 223, 381

fibula anterior 250

fibula arcuata 136

fibula posterior 250

fides 137

fidicen 137

figulus 37

filia 10, 92

filius 9, 91

filum 137

filum Ariadnae 137

filum electricum 130

fiscus 137

fistuca 218

fistula 130, 168, 183

flabellifera 138

flabellum 138

flagellum 139

flamen 139

flamen Dialis 139

flos aconiti 3

foculus 140

focus 140, 209
folium 2, 202
follis 141
fons 142
foramen 257, 291
forfices 261
forma 368
forma Urbis 29, 313
fornaculum 143
fornax 143
fornicari 144
fornix 144
Fortuna 144
forum 71
fossa 71, 144, 207
fovea 144
frenare 145
frenum 145
fretum 146
fretum Gaditanum 146
fretum Siculum 146
frigidarium 145, 176
fritillus 147
frons, ndis 68
frons, ntis 103, 249
frustulum 221
fucus 147
fulcrum 361
fulgur 342
fullo 148, 35
fullonica 148
fullonium 148
fulmentum 244
funale 148
funalis 149
funambulus 149
funda 149, 223, 377
funda librilis 150
funditor 150, 223
funebria 151
funebria 151
funis 16, 170, 188, 251, 345
funus 150
furca 151, 68
Furcae Caudinae 64
furnus 151
fuscina 360
fusor 246
fusus 152, 261

G
Gades 146
galea 153, 108, 223, 224, 225
galea cristata 153
Gallia Romana 153, 154
Ganymedes 364
Gemini 391
gemma 154
gena 103
gener 10
gens 155

gentilis 155
genu 104
geometria 155-160, 33, 34,
Germania 161
gesticulator 226
gestus adorandi 5
gestus precandi 286
Gigantes 388
girgillus 292
glacies 342
gladiator 83
gladius 224
globus 261
glomus lanae 355
glos 9
gluma 324
gluten 161
glutinator 161
glutinum 161
gnomon 368
Gorgo 7, 8
gradus 24, 147, 227, 351, 387
gradus affinitatis 10
gradus cognationis 91,92
grammatica 33, 34, 363
grando 342
graphium 161
gravitas 281
gremium 162
gryphus 163
gryps 163
gubernaculum 20, 31, 163, 291
gubernator 163, 290
gurgis 163
gustare 312
gustus 312
gutta 165
guttur 250
gutturales 249
gyrus 166

H
habena 167, 145
hamus 167
harena 15
harundo 168
hasta 188, 223
haurire 316
hebdomas 168
Hecate 169
Hecate triformis 169
hedera 289
helciaricus 170
helcium 170
Hellespontus 271
Helvetia Romana 169, 170
heros 22
Hesperides 171
hic 209
hiems 173
hinc 209

hippocampus 172
Hispania Romana 171, 172, 146
histrion 268
holus 385, 386
Horae 173
horologium 173
hortator 174
hortator remigum 174
hortolanus 236
hortus 174, 128, 193
hortus deliciarum 34
hortus Hesperidum 171
hostia 175, 24
hostiae infula 182
huc 209
hypocaustum 176, 143

I

ianitor 265
ianua 85
lanus 177
lanus biceps 177
lanus bifrons 177
lason 271, 375
ibi 209
ichnographia 47, 125, 126, 127, 128, 185, 186
ignis 129
imaginarius 178
imaginari 178
imaginifer 178
imago 177
imago acu picta 273
imago clipeata 88, 364
imber 168, 342
imbrex 341
imitari 226
impedimenta 179
imperator 11
impluvium 125, 193
impressor 389
incunabula 179
impressio 368
in antis 343
in antis duplex 343
incus 180
inde 209
index 181, 103
index ciborum 181
index voluminis 181
infans 9
inferi 69
infula 181
infula sacerdotis 181
infundibulum 230
initialis 182
initiatio 228
Ino 271
inscriptio 356
insigne 182
insigne navis 182
institor 75, 110

instrumenta musica 183
instrumenta scribendi 186
insula 185, 253
insula Vulcaniae 388
interlunium 211
intestina 104
introrsum 294
inventor 267
Iovis dies 168
irasci 312
iris 246, 342
irretire 299
istic 209
istinc 209
istuc 209
Italia 187, 188
iungere 187
iugulum 103
iugum 187, 204
iugum textorium 188, 281
Iuno Sospita 43
ius imaginum 177
ius talionis 339
iuvenis 9

K

Kalendae 61

L

labarum 189
labiales 249
labium 103, 249
labrum 189
labyrinthus 190
lacerta 191
lacertus 250
Lachesis 261
laconicum 45
lacunar 192
lacus 83, 84, 277
laena 139
lanx 191, 204
lapidica 38
lapicidina 192
lapidarius 192
lapis 369
laquear 192
laqueus 194
Lares 6, 56, 379
larva 269
later 195, 196
laterculus 195
laterna 195, 196
latifundium 195
latitudo 294
Latium 197, 198
laurus 375
lectica 197
lecticarius 197
lectisternium 199
lectulus 197

lectus 199
legenda 199
legenda Aurea 200
legumen 270
lens biconcava 244
lens biconvexa 244
lens concava convexa 244
lens convexa concava 244
lens plana concava 244
lens plana convexa 244
lentes 386
lentes convergentes 244
lentes divergentes 244
Leo 391
lepus 214
levir 9
libella 201
liber 201
libra 204, 329, 355
Libra 322, 392
librarius 203
Liburna 204
Liburnica 204
Liburni 204
lictor 205, 11, 218
ligare 105
ligo 206
ligula 90
lima 206
limen 206
limes 206
limes Germaniae Superioris 207
limes Rhaeticus 207
linea 168
linea conchalis 155
linea curva 155
linea inclinata 157
linea flexuosa 155
linea ovalis 156, 157
lineae parallelae 158
linea perpendicularis 158
linea recta 155
linea vere ovalis 158
lingua 249
litus 207, 253
lituus 207, 43
locus 209
longitudo 294
lorica 8
lucerna 210
lucerna fictilis 141
lucerna pensilis 210
ludere utro uncto 372
ludus talorum 340
ludus Troianus 365
luna 211, 119, 392
luna crescens 211
luna decrescens 212
Lunae dies 168
lupa 270
lustratio 334

luteum 252
lycopersicum 386
lyra 137, 183, 184

M

macellarius 35, 213
macellum 213
maceria 174
machina pictoris 272
maeandrus 213
magistratus curulis 178, 312
maiestas 215
maiestas domini 215
malleus 215
malus 31, 100
mane 298
manica 216, 95
manipulus 216
mansuetarius 216
manubrium 87
manu emittere 217
manumissio 217
manus 103
Mare Nostrum 146
margen ferreus 368
maritus 9
Mars 388
Martis dies 168
marsuppium 330
Massicus 63
mater 92
matertera 92
matutinus 298
Mauretania 146
Mausoleum 217
Mausoleum Hadriani 219
Mausolus 219
maxilla 250
Medea 271
medius digitus 103
medulla 250
Melpomene 233
membrana 311
membrana cornea 246
membrana reticulata 245
membrana sclerotica 245
meminisse 312
mensis 177
mensura 219
mensurae publicae 220
mentum 104, 249
Mercurii dies 168
meretrix 268
meridianus 298
meridies 67, 298
messis 221
messor 221
meta 82, 364
mica 221
micare 222
microscopium 224

miles Romanus 223
milia passuum 226
miliarium 226
mimus 226
miliarium aureum 226
Minerva 29
miniatura 228
minio 227
minium 182
Minotaurus 190
Mithra 227
Mithraeum 227
modiolus 18, 19, 69, 109, 296, 301
modus 220
moenia Serviana 314
mola 229
mola aquaria 229
moles caeli 42
molinarium 35, 229
Moneta 229
monetarii 229
mons 334
mons ignivomus 388
monumentum Ancyrantum 231
monumentum funebre 86
mortarium 231, 386
mulctra 232
mulctrum 232
mulier 10
munitio 207
murex 232, 292
murex ferreus 233
murus 386
Musae 233
muscus 233
muscus hepatica 233
musica 33, 34
mysta 228

N

nares 103, 312
nassa 235
nassiterna 236
nasus 103, 249
naumachia 235
navis 237
navis actuaria 238
navis longa 237
navis oneraria 238
navis tecta 237
navis turrita 238
nebula 342
nectere 136
nepos 91
neptis 91
Neptunus 363
nere 152
Nereides 172, 364
nervus 27, 183
nervus opticus 245
nimbus 238

nix 342
noctua 240
nocturnus 298
nomenclator 240
nomenclatura 240, 241
nomen gentile 155
Noricum 295
norma 240
nota 241
notae Tironiae 241
notarius 241
nova luna 211
noverca 9
nox 298
nubes 342
nucamentum 276
nucleus 42, 383
nummus 94
nundinae 242
nundinari 242
nurus 9
nux 385, 386

O

obeliscus 243
obliquitas 267
oblongum 160
occare 307
occasus 298
occatio 297
occidens 67, 298
occidentalis 298
Oceanus 249
Oceanus Atlanticus 146
ocularia 243
ocularium 244
oculus 245, 31, 103, 312
octangulus 245
octogonum 245
officina 246
officium 246
olfacere 312
olfactus 312
olla 112
operculum 368
opifera 31
opus 247
opus albarium 340
opus Alexandrinum 247
opus arcatum 22
opus arenatum 340
opus caelatum 306
opus incertum 247
opus marmoratum 340
opus reticulatum 247
opus spicatum 247
opus tessellatum 247
opus testaceum 340
oraculum 247
orans 5
orbiculus 248

orbis 81, 301
orbis terrarum 249
orchestra 352
ordo velleris aurei 375
organum 110
organum hydraulicum 183
oriens 67, 298
orientalis 298
origo 143, 179
orthographia, 125-128, 185, 186
ortus 298
os oris 249, 103
os ossis 250
os sessibuli 250
oscillatio 251
oscillum 251
ostium 86, 125, 127
ovis 175, 375
ovum 252

P
pabulum 285
paeninsula 253
paganus 156, 254
pagina 368
pagus 253
pala 254
palatales 249
palatium 254
palatum 249
palimpsestus 255
palla 382
pallium 255, 224
palma 5, 103
palpebra 104, 246
paludamentum 256
palus 256
panem et circenses 82
Pannonia 295
pannus 349
Pantheon Romanum 257
papilio 259
papyrus 260
Parcae 261
paries 261
paries craticius 262
paries latericius 262
patella 375
patena 262
pater 91
patera 262
patruelis 91
patruus 91
pavimentum 263
pavimentum stratum 383
pavo 263
pecten 264, 188
pectus 103
pecunia 94
pedes 31
pedicae 216

pediludium 265
Pegasus 51, 79
Penates 379
penicillus 214, 272
peniculus 272
penna 138
pentagramma 288
pergula 265
peripheria 156, 160
peripteros 344
peristylum 125, 126
perna 75
perpendicularum 267, 202, 229
persicum 385
persona 267
personatus 269
perspicilla specularia 243
pertica 75
pes 104
pharetra 28
pharmacopola 269
pharmacopolium 269
pharus 270
phaselus 270
phases lunae 211
Phoebus 20
phorminx 184
Phosphorus 44
Phrixus et Helle 271
pictor 272
pictura 272
pictura in linteo 273
pictura in sipario 273
pictura in tabula 272
pictura inusta 273
pictura textilis 273
pictura udo tectorio picta 273
pila 273
pilae 368
pila 273
pila electrica 274
pilare 386
pileolus 275
pileus 275, 139, 218
pingere 272
pinna 275
pinna gubernaculi 276
pinnae moenium 275
pinus 276
piscator 276, 168
piscatorius 276
Pisces 392
piscina 277
piscis 44
pistillum 278, 231
pistor 277, 35
pistrina 278
pisum 385
pittacium 279
plaga 299
planta 104

plaustrum 279
plenilunium 212
pluma 275
pluteus 203, 336
pluvia 342
poculum 62
pollex 103, 152
polus 44
Polyhymnia 234
polypus 44
polyspaston 248
pomarium 280
pomarius 280
pometum 280
pompa 346
pondus 280, 188, 329
pons 281
pons Cestius 281
pons Fabricius 282
pons sublicius 282, 332
porta 282
porta praetoria 72
porta versatilis 89
porticus 283, 259
porticus Liviae 284
portitor 79
portus 284
positio 209
posticum 126
postmeridianus 298
post meridiem 298
praecinctio 47
praeco 285
praefurnium 143
praesaepe 285
praesaepium 285
precatio 286
prelum 261, 286, 368
prelum hydraulicum 287
premere 286, 358
pressorium 286
principium 143, 179
privigna 10
privignus 10
profunditas 294
proles 287
proletarius 287
promontorium 57, 253
proportio 287
proportio divina 288
proportionalitas 288
propugnaculum 289
prora 290, 31
proreta 290
proreus 290
Proserpina 362
prorsum 294
prostylos 343
pruina 342
pruna 290
prunum 385

prunus 385
puella 10
puer 9
pugillares 91
pugna navalis 236
pullus 252
pulmo 104
pulpitum 301
pulvinar 198
pupa 291, 2
pupilla 246, 291
puppis 291, 20, 31, 290
pupula 246
purpura 291, 232
purpuratus 292
putamen 252
puteal 292, 347
puteus 292
pyrobolum vi atomica explodens 42
Pythia 248
pyxis 292

Q

quadra prima 212
quadra ultima 212
quadrangulum 159
quadrans 72
quadratum 160
quadriga 293
quadrigae 293
quadrigatus 293
quadrivium 293, 33
quantitas 220
quo 209
quoversum 294
quorsum 294

R

radius 295, 160, 301, 349
Raetia 295
ramale 68
raster 297
rastrum 297
ratis 297
receptaculum 25
rectitudo 267
regio 297
regio Basiliensis 298
regiones caeli 298
regula 156
remus 31
repagulum 85
repositorium 112
restis 325
rete 299
rete araneae 299
retiarius 299
reticulum 300, 382
retinaculum 368
retrorsum 294

rhetorica 33, 34, 363
rhomboides 159
rhombus 159
rogus 300, 97, 98
rosa 385
rosa canina 289
rostra 300
rostrum 301, 31, 290
rostrum navale 301
rota 301, 25
rota aquaria 302
rota Fortunae 302
rota tractoria 302
rudus 383
runcina 241, 355
rursum 294

S

sacerdos 86
sacrificium 199
sacrum Apollinis 119
saepes 303
saepia 303
saeptum 76, 303
sagitta 28, 73
Sagittarius 391
sagum 256
Salacia 363
salmo 303
sal nitratum 274
saltatio 68
sapere 312
sarcina 305
sarcinae exercitus 179
sarcinae 179, 305
sarcophagus 305
sarculum 307
sarire 307
sartago 307, 111
satio 333
Saturnalia 307
Saturni dies 168
satyrus 358, 372
scabellum 309
scaena 351
scala 307, 72
scala cochleata 90
scalpellum 308
scalprum 308, 355
scamnum 309
scapha 309
scapha complicabilis 310
scapula 250
scapus 17, 274, 329
sceptrum 310
schedula 279
scobes 274
scopa 310
scopae 310
Scorpio 392
scriptorium 203

sculptor 37
scutica 365, 366
scutum 8, 88, 223
scytala 311
secans 159
sectio 145
sectio aurea 288
sector 160
securis 205, 225
sedile 387
segmentum maius 159
segmentum minus 159
segmenta similia 160
sella 272, 361
sella curulis 312, 116
sella equestris 129
semicirculus 159
semita 106
senex 9, 268
sensus 312
sentire 312
septem mirabilia mundi 219
septentrio 44, 67
Septentrio 377
septentrionalis 298
septentriones 312
septimana 168
Septimontium 313
sepulcrum 72
sera 314, 85
serpens alatus 362
serra 355
sidus 30
sigillare 347
sigillum 186, 292, 315
signifer 314, 11, 224
signum 315, 11, 224
silex 315
silicernium 316, 9
silva 334
simpulum 316
simulacrum 268
sinistrorsum 294
sinus 317, 253
siparium 273
siphon 174, 190
siphunculus 174
Sirenae 317
Sirenes 317
sistrum 318, 183
sitella 318, 319
situla 318, 319
socer 9, 10
socrus 9, 10
sol 120, 391
solarium 174, 386
solea 319, 381
soleae oblongae 319
solium 321
solstitium 321
solstitium aestivum 321

solstitium hibernum 321
Solis dies 168
sors 318
spatha 355
specillum 243
spectator 352
speculum 323, 382
spelunca 334
sphaeristerium 323
spica 323
spicarium 386
spina 324, 81
spina dorsi 250
spina navis 290
spira 136
sponda 325
spondere 325
spongia 325
sponsa 325
sponsalia 284, 326
sponsus 325
sporta 326
sportella 326
sportula 326
spuma 342
stabulum 327
stagnum 277
stamen 188
statera 329, 17
stativa 15
statua 329
statumen 383
stella polaris 312
stereoscopium 243
stigma 241
stillicidium 330, 341
stilus 161, 186
stiva 24
stola 382
stramentum 68
strenae 330
strigilis 330, 325
structor 27
structura 27
Styx 79
sublica 331
subtemen 188
suburbanus 331
suburbium 331
sucula 368
sudatio 45
suere 335
sufflamen 333
suggestum 12
suggestus 301
sulcus 333
suovetaurilia 334
supercilium 104
superficies 334
supplex 335
supplicatio 335

sura 104
surculus 311
sursum 294, 302
sus 334
sutor 335, 37
sutrina 336
symbolum 336
symbolus 336

T
taberna 337, 127, 193
taberna macellaria 213
tabernaculum 338
tablinum 125, 126, 193
tabula 337, 186
tabula lusoria 1
Tabula Peutingeriana 337
tachygraphia 241
tactus 312
taeda 339
talaria 339, 59
talio 339
talpa 340
talus 340, 147
tangens 159
taurus 334
Taurus 391
tectorium 340
tegula 341, 385
tela 188
tela araneae 299
telamones 42
Tellus 341
temo 342, 25
tempestas 342
templum 343, 43
tempus 177, 298
tempus futurum 177
tempus praeteritum 177
tensa 345
tentorium 345, 71
tentorium militare 260
tepidarium 45, 176
terebra 347
terebrare 347
Terpsichore 233
terra 119, 129
terra cocta 348
terra sigillata 347
tessera 347
tessera congiarii 96
tessera frumentaria 348
tessera hospitalis 348
tessera lusoria 348
testa 348
testudo 349
texere 349
textor 349, 35
textrix 349
textum 349
textus 350

Thalia 21, 233
theatrum 351
thermae 45, 145
Thermae Diocletiani 145
thermopolium 353
tholus 343
thyrsus 353
tiara 353
tiara recta 354
tiaras 353
tibia 104, 183, 250, 354
tibicen 354
tibicina 354
tignarius 355, 37
tignum 193
tinctor 355, 292
tinctorium 355
tinctura 355
tinnitus 356
tintinnabulum 356
Tiro 241
titulus 356
toga 381
toga praetexta 56
tomaculum 76
tonitru 342
torcular 356
torculum 356
torus 357
torus columnae 357
tragoedia 267
traha 358
trahea 358
transenna 359
trapezium 159
triangulum 159
triangulum acutangulum 160
triangulum aequicrurum 159
triangulum aequilaterum 159
triangulum obtusangulum 159
triangulum rectangulum 160
triangulum scalenum 160
triclinium 359, 193
tricuspis 360
tridens 360
trifidus 360
triforium 360
triglyphus 165
Triptolemus 361
tripus 361, 111
Triton 363
trivium 363, 33
trochlea 368
trochus 364
troia 365
tropicus circulus Cancrī 392
tropicus circulus Capricorni 392
trua 365
truia 365
trulla 365
trutina 329

tuba 183, 225, 363
tubulus 244
tundere 215
tunica 223, 381
turbo 365
turris 366, 208
turris ventorum 173
turritus 366
tus 334
tympaanum 367, 183, 185
tympaanum dentatum 229
typographia 367
typographus 368, 389
typotheta 368
typus 368
typus aeneus 368

U
ubi 209
umbilicus 369
umbo 369
umbra 265
umbraculum 370, 292
umbrella 370
umerus 104
umor vitreus 245
uncus 167
unde 209
unguentarius 370
unguentum 370
Urania 234
urceatim 371
urceus 371
urna 371
Ursa 312
utensilia 371
utensilia culinae 111
uter 372
uterus 369
utopia 373
utrarius 372
utricularius 374
uva 60, 356, 358
uxor 10

V
vadium 375
vallis 334
Vallis Poenina 295
vallum 71, 207, 386
vapor 342
vaporarium 176
vas 325
vas diatretum 122
vas unguentarium 370
vates 375, 21
vaticinatio 375
vaticinor 375
vehiculum 345
velares 249
vellus aureum 375

velum 376, 31, 250, 382
venatio 376
venator 376
Veneris dies 168
venter 103
ventus 377
ventus adversus 377
ventus secundus 291, 377
Venus 114, 388
ver 173
versus 368
vertebra 250, 324
vertex 378, 103
veru 378
vesper 298
vespertinus 298
Vesta 379, 380
Vestalis 379
vestiarium 382
vestiarius 381
vestibulum 381, 125, 193
vestimenta militum 223
vestimenta mulierum 382
vestimenta Romana 381
vestimenta viroorum 381
vetula 10
vexillum 383, 11, 225
via 383, 127
via Appia 384
via brevior 95
via praetoria 72
via principalis 72
via strata 315, 384
viator 384
Victoria 148
vicus 71
videre 312
vigiles 385
vigiliae 385
villa rustica 385
vimen 235
vinarius 38
vindemia 356, 385
vindicta 218
Vindonissa 71
vinea 356
vinctum 356
vinum 385
vir 9
virga 205
virgo 10
Virgo 391
virgo Vestalis 379
vis atomica 42
visus 312
vitellus 252
vitis 356, 57
vitra ocularia 243
vitricus 9
vitta 387, 181
volumen 161, 202, 203

volumen epistulae 186
vomer 24, 25
vomitrium 387, 113
vortex 378
Vulcanus 388
vulpes 214

X
xylographia 389

Z
zincum 274
zodiacus 391
zona 391
zona nivalis 392
zona temperata 392
zona torrida 392

index locorum

A

Ammianus 15, 7, 6: 350
Anthol. Latina 65, 3 M.: 318
Ambrosius 3 de Dav. 11, n. 89: 368
Arnobius 3, 41: 379

B

Bellum Alex. 1: 98

C

Caelius Aurelius, Tard. 1, 4: 222
Caesar, B.C. 1, 28, 4: 307
– 3, 76: 305
Caesar, B.G. 1, 6, 2: 375
– 1, 26: 180
– 4, 25: 150
– 7, 69: 134
– 7, 72, 4: 275
– 8, 43: 113
– 8, 51: 175
Calpurnius, Ecl. 4, 25: 232
Cassiodorus, de geom. 6: 288
Cassiodorus, Hist. Eccl. 10, 4: 14
Cato, r.r. 1, 2: 61
– 18, 7: 263
– 74: 232
Catullus 3, 1: 114
– 4, 1: 271
– 71, 4: 207
Cicero, Acad. post. 1, 2, 8: 143
– 2, 81: 340
– 2, 94: 11
– 4, 25: 340
– ad Att. 5, 20, 3: 123
– 6, 1, 12: 60
– 15, 14: 227
– ad fam. 7, 18: 255
– de orat. 3, 9, 36: 60
– 1, 6, 23: 179
– 2, 83, 338: 354
– divin. 2, 6, 17: 120
– 2, 41, 85: 222
– 2, 41, 86: 163
– 1, 45, 101: 231
– in Pis. 3, 7: 301
– nat. deor. 1, 10, 24: 297
– 1, 20, 52: 44

– 1, 20, 54: 180
– 2, 2, 6: 69
– 2, 27, 67: 141
– 2, 48, 123: 299
– 3, 34, 84: 285
– prov. cons. 11, 27: 335
– off. 1, 13, 39: 93
– 1, 44, 157: 134
– orat. 71, 235: 310
– Quinct. 13, 45: 268
– senect. 6, 17: 163
– Tusc. 1, 25, 62: 241
– 5, 23, 64: 295
– Verr. 3, 23, 9: 163
– 4, 1, 1: 272
– 4, 14, 32: 347
– 4, 17, 37: 194
– 4, 48, 106: 369
– 4, 53, 118: 142
– 5, 30, 77: 115
Columella, r.r. 4, 25, 1: 317
– 7, 9, 12: 241
– 8, 17, 6: 63
– 9, 5, 3: 14
– 11, 2, 31: 322
– 12, praef. 3: 371
– 12, 57, 1: 232
Comenius, Orbis pictus 7: 342
– 8: 334
– 36: 9,10
– 93: 367, 368
Curtius 8, 13, 23: 297

G

Gellius 5, 6: 102

H

Hieronymus, ep. ad Fur. 13: 323
– ep. 140 n. 8, 2: 386
Historia Augusta 17, 21: 216
Horatius, carm. 1, 4, 13, 14: 337
– 3, 24, 9: 279
– 4, 3, 23: 137
– c. s. 61, 62: 20
– ep. 1, 2, 69, 70: 348
– 1, 10, 36: 145
– 1, 14, 2: 141

- 1, 16, 50: 144
- 1, 18, 84: 262

I

- Isidorus 15, 4, 7: 343
- 18, 3, 5: 216
- 20, 16, 6: 60
- Iuvenalis 10, 81: 82
- 15, 127: 271

L

- Livius 1, 18, 7: 207
- 5, 13, 6: 199
- 9, 40, 3: 108, 153
- 9, 46, 5: 12
- 21, 18, 13: 317
- 22, 10, 9: 199
- 25, 2, 8: 96
- 30, 10, 14: 98
- 40, 51, 4: 274
- 41, 27, 7: 315
- Lucanus 1, 237: 209
- Lucretius 1, 739: 362
- 5, 966 s.: 85

M

- Macrobius, sat. 1, 16, 34: 242
- 6, 4, 4: 387
- somn. 2, 2, 4 ss.: 335
- Manilius 1, 679: 47
- 4, 197ss.: 241
- Martialis 1, 117, 7: 308
- 3, 82, 15: 107
- 9, 18, 3s.: 19
- 10, 37, 17: 326
- Martianus Capella 9, 314: 107

N

- Nepos, Att. 13, 3: 37
- 14, 3: 331

O

- Ovidius, ars. am. 3, 562: 303
- 3, 591: 194
- fasti 1, 117, 18: 177
- 3, 36: 222
- halieut. 18 ss.: 304
- heroid. 16, 263: 221
- 18, 13: 167
- met. 1, 147: 3
- 2, 107s.: 342
- 6, 22: 152
- 6, 79: 7
- 8, 247 ss.: 81
- 8, 617: 59
- Pont. 4, 10, 5: 165
- trist. 5, 7, 49: 55

P

- Paulus, ad Cor. 1, 13, 12: 323
- Paulus Festus p. 78 M.: 131

- p. 113, 1 M.: 181
- p. 207, 4 M.: 275
- p. 272, 8 M.: 297
- p. 302, 4 M.: 333
- Paulus Dig. 1, 5, 1: 268
- Petronius, sat. 27: 273

- 29: 5
- 34, 4: 372
- 34, 6: 279
- 44, 18: 371
- 100: 97
- Phaedrus 1, 26ss.: 262
- 2, 7, 1: 305
- 2, 7, 2: 137
- 4, 3: 356
- Plautus, Amph. 148: 196
- 341: 388
- Bacch. 711: 283
- Capt. 22: 273
- 268/69: 264
- 663: 307
- Cas. 309-311: 151
- 358/59: 319
- Curc. 203/4: 7
- Merc. 695/96: 174
- 830: 206
- Mil. glor. 504: 341
- Most. 41: 370
- 275: 147
- Pers. 26/27: 114
- 471: 95
- Trin. 1013/14: 353
- Plinius H. N. 2, 211: 306
- 7, 10: 164
- 7, 198: 220
- 8, 104: 340
- 10, 156: 108
- 11, 188: 246
- 13, 71: 260
- 16, 52: 339
- 18, 35: 195
- 18, 107: 278
- 18, 180: 297
- 35, 89: 140
- 36, 172: 267
- Plinius Valer. 2, 17: 286

Q

- Quintilianus 5, 10, 101: 194
- 5, 11, 21: 88
- 8, 2, 7: 378
- 9, 2, 41: 178

R

- Rutilius, de reditu 1, 455/56: 290

S

- Seneca, Contr. 1, praef. 9: 247
- ep. 90, 10: 68
- 90, 24: 163
- 115, 2: 66

- ira 2, 19: 129
- quaest. nat. 4b, 13, 8: 370
- 5, 13, 3: 366
- Servius, ad Aen. 1, 506: 321**
- 2, 616: 238
- 5, 114: 237
- 10, 538: 181
- 11, 788: 290
- Suetonius, Galba 6, 1: 149**
- Nero 12, 9: 292

T

- Tacitus, hist. 2, 98: 130**
- 3, 34: 289
- Terentius, Eun. 729: 247**
- Tibullus 1, 5, 70: 144**
- 1, 6, 34: 86
- 1, 7, 55: 287
- 2, 1, 45: 356

V

- Valerius Flaccus 2, 235: 339**
- Varro, L.L. 5, 122: 262**
- 6, 8: 322
- 7, 83: 44
- 7, 108: 314
- r.r. 1, 1: 341
- 1, 2, 6: 280
- 1, 11, 2: 84
- 1, 14, 4: 195
- 1, 48, 1: 323
- 1, 54, 1: 356
- 3, 8, 1: 340
- Vergilius, Aen. 1, 727: 148**
- 2, 2: 358
- 3, 130: 291
- 4, 239ss.: 339
- 5, 103: 290
- 5, 583ss.: 365
- 6, 797: 42
- 8, 354/55: 8
- 10, 116: 322
- 12, 725: 131
- Georg. 1, 144: 113
- 2, 384: 372
- 3, 297/98: 216
- 4, 33 ss.: 13
- Vitruvius 1, 6, 4: 245**
- 2, 1, 3: 168
- 4, 1, 1: 65
- 5, 10, 1: 176
- 5, 11, 2: 132
- 6, 5, 2: 109
- 6, 8, 5: 267
- 9, praef. 6: 240
- 10, 4, 3: 69
- 10, 5, 1: 302
- 10, 5, 2: 229

proverbia et dicta

ab acia et acu omnia exponere 5
ab ovo usque ad mala 252
ad (perfectum) unguem castigare 206
ara focusque 141
architectus architecto invidet 27
asino clitellas imponere 88
bovi clitellas imponere 88
compendio ducere aliquem 95
compendium facere 95
concitare equum calcaribus 60
cribro aquam ferre 108
cumulos auri struere 112
dignus est quicum in tenebris mices 222
duos parietes de eadem fidelia dealbare 262
ex arca domoque solvere aliquid 26
filum in acum conicere 137
frenum mordere 145
fuco illinere aliquid 147
hircos mulgere 232
homo totus de capsula 66
in caducum parietem inclinare 262
incudem eandem tundere 180
in litus arenas fundere 207
in portum ex alto invehi 284
in portum se recipere 284
in vado (salutis) esse 375
ipse mihi asciam in crus impegi 40
lateres coquere 195
laterem lavare 195
ligna in silvam gerere 207
naturam expellas furca, tamen usque recurret 151
navem perforat, qua ipse navigat 238
paene in foveam incidi 144
panem et circenses 82
per transennam aspicere aliquid 359
quod non fecerunt barbari, fecerunt Barberini 257
quo semel est imbuta recens, servabit odorem testa diu 348
sarcinis gravare 305
scopae solutae 311
scopas dissolvere 310
sulcos ducere, agere 333
sutor, ne supra crepidam 335
struere cumulos auri 112
vaticinium ex eventu 375
ventis dare vela 377

fontes praecipui imaginum

- Ammann W., Baustilkunde, Bern 1969
Beer J. E., Die Rose der Kathedrale von Lausanne, Bern 1952
Bilderatlas zur Kulturgeschichte I, Aarau 1968
Blümner H., Technologie der Gewerbe und Künste bei Griechen und Römern, Leipzig 1875-1887
Campbell L. A., Mithraic Iconography and Ideology, Leiden 1968
Comenius J. A., Orbis Sensualium Pictus, Nürnberg 1658
Daremberg Ch. / Saglio E., Dictionnaire des Antiquités grecques et romaines (10 tomes)
Paris 1877–1911 (delineavit P. Sellier)
Dictionnaire archeologique des techniques, Paris 1963
Gaffiot F., Dictionnaire illustré Latin-Français, Paris 1934
Gerhard E., Auserlesene Vasenbilder, Berlin 1840-1858
Grenier A., Manuel d'archéologie gallo-romaine, Paris 1931 ss.
Grimal P., Nous partons pour Rome, Paris 1962
Guhl E., / Koner W., Das Leben der Griechen und Römer nach antiken Bildwerken dargestellt,
Berlin 1862
Harrison J. E., Prolegomena to the study of Greek religion, London 1903-1911, reprint 1961
Harrison J. E., Themis, London 1963 (reprint)
Kähler H., Rom und seine Welt, München 1960
Koepp H., Bildwörterbuch der Architektur, Stuttgart 1968
Laur-Belart R., Führer durch Augusta Raurica, Basel 1937
Lavedan P., Dictionnaire illustré de la mythologie et des antiquités grecques et romaines, Paris 1952³
Luckenbach H., Kunst und Geschichte, München, Berlin 1926
Lübkers F., Reallexikon des klassischen Altertums für Gymnasien, Leipzig 1891
Martin K., Kunst des Abendlandes, 1. Teil, Antike, Karlsruhe 1965
Mir J., Nova verba Latina, Barcinone 1970
Mužik H. / Perschinka F., Kunst und Leben im Altertum, Wien/Leipzig 1909
Nack E./Wagner W., Land und Volk der alten Römer, Wien 1956
Oerberg H. H., Lingua Latina secundum naturae rationem explicata, Copenhagen 1965³
Olaus Magnus, Historia de gentibus septentrionalibus, Romae 1555 (facs.)
Overbeck J., Pompeij in seinen Gebäuden, Altertümern und Kunstwerken, 4. A. im Ver. m. A. Mau,
Leipzig 1884
Pelletier A., Lexique d'antiquités romaines, Paris 1972
Réau L., Dictionnaire illustré d'art et d'archéologie, Paris 1930
Reisch G., Margarita Philosophica, Basileae 1503
Rich A., Dictionary of Roman antiquities, London 1849
Roscher W. H., Ausführliches Lexikon der griechischen und römischen Mythologie, Leipzig 1884-1937
Roux G., Delphi, Orakel und Kunststätten, München 1971
Schwarz G. Th., Die Kaiserstadt Aventicum, Bern/München 1964
Voit L., Raetia Latina, Düsseldorf 1959
Von Kampen A., Descriptiones nobilissimorum apud classicos locorum, Series I., Gotha s.d.
Wegener M., Das Musikleben der Griechen, Berlin 1949
Welper E., Elementa geometrica, Argentorati 1620
Witzig H., Das Zeichnen in den Geschichtsstunden, Zürich 1939

